



**TRUE FOOD SERVICE  
EQUIPMENT, INC.**

2001 East Terra Lane • O'Fallon, Missouri 63366  
(636)240-2400 • Fax (636)272-2408 • (800)325-6152 • Intl Fax# (001)636-272-7546  
Parts Dept. (800)424-TRUE • Parts Dept. Fax# (636)272-9471 • www.truemfg.com

Project Name: \_\_\_\_\_

Location: \_\_\_\_\_

Item #: \_\_\_\_\_ Qty: \_\_\_\_\_

Model #: \_\_\_\_\_

A/A #

S/S #

Model:  
**TR2F-2S**

**TR Spec Series:**  
*Reach-In Solid Swing Door Freezer*



**TR2F-2S**

- ▶ Designed using the highest quality materials and components to provide the user with colder product temperatures, lower utility costs and exceptional food safety.
- ▶ Oversized, factory balanced, refrigeration system holds -10°F (-23.3°C) for the best in food preservation. Ideal for frozen food and ice cream.
- ▶ 300 series stainless steel exterior and interior. The very finest stainless with higher tensile strength for fewer dents and scratches.
- ▶ Equipped with one (1) interior kit option per section, factory installed. Four (4) different interior kits available.
- ▶ Positive seal self-closing doors with 120° stay open feature. Lifetime guaranteed door hinges.
- ▶ Lifetime guaranteed recessed door handles.
- ▶ Automatic defrost system time-initiated, temperature-terminated. Saves energy consumption and provides shortest possible defrost cycle.
- ▶ Entire cabinet structure and solid doors are foamed-in-place using Ecomate. A new, innovative, high density, polyurethane insulation that has zero ozone depletion potential (ODP) and zero global warming potential (GWP).

**ROUGH-IN DATA**

Specifications subject to change without notice.  
Chart dimensions rounded up to the nearest 1/8" (millimeters rounded up to next whole number).

Model	Doors	Cabinet Dimensions (inches) (mm)			HP	Voltage	Amps	NEMA Config.	Cord Length (total ft.) (total m)	Crated Weight (lbs.) (kg)
		L	D	H*						
TR2F-2S	2	51 3/8 1305	34 3/8 880	78 1/4 1988	3/4	115/60/1	13.0	5-20P	9 2.74	704 320

\* Height does not include 5" (127 mm) for castors, 6" (153 mm) for optional legs, and 1" (26 mm) for system mechanical components.



Printed in U.S.A.

APPROVALS:

AVAILABLE AT:

Model:  
**TR2F-2S**

**TR Spec Series:**  
*Reach-In Solid Swing Door Freezer*



**STANDARD FEATURES**

**DESIGN**

- True's solid door reach-in's are designed with enduring quality that protects your long term investment.
- Designed using the highest quality materials and components to provide the user with colder product temperatures, lower utility costs and exceptional food safety.

**REFRIGERATION SYSTEM**

- Factory engineered, self-contained, capillary tube system using environmentally friendly (CFC free) 404A refrigerant.
- Extra large evaporator coil balanced with higher horsepower compressor and large condenser maintains -10°F (-23.3°C) cabinet temperature. Ideal for both frozen foods and ice cream.
- Sealed, cast iron, self-lubricating evaporator fan motor(s) and larger fan blades give True reach-in's a more efficient low velocity, high volume airflow design. This unique design ensures faster temperature recovery and shorter run times in the busiest of foodservice environments.
- Top mounted refrigeration system with evaporator positioned out of food zone to maximize capacity.
- Automatic defrost system time-initiated, temperature-terminated. Saves energy consumption and provides shortest possible defrost cycle.
- Automatic evaporator fan motor delay during defrost cycle.

**CABINET CONSTRUCTION**

- Exterior - 300 series stainless steel door(s), front, sides, back and bottom.
- Interior - 300 series stainless steel liner and floor.
- Insulation - entire cabinet structure and solid doors are foamed-in-place using Ecomate. A new, innovative, high density, polyurethane insulation that has zero ozone depletion potential (ODP) and zero global warming potential (GWP).
- Welded, heavy duty steel frame rail, black powder coated for corrosion protection.

- Frame rail fitted with 4" (102 mm) diameter stem castors - locks provided on front set.

**DOORS**

- 300 series stainless steel exterior and liners. Doors open within cabinet dimension.
- Door locks standard.
- Lifetime guaranteed recessed door handles. Each door fitted with 12" (305 mm) long recessed handle that is foamed-in-place with a sheet metal interlock to ensure permanent attachment.
- Positive seal self-closing doors with 120° stay open feature. Lifetime guaranteed door hinges.
- Magnetic door gaskets of one piece construction, removable without tools for ease of cleaning.

**SHELVING**

- One (1) factory installed, interior kit option per section. Four (4) different interior kits available (see Kit Options). Pilasters and tray slides are factory installed at no charge.

**LIGHTING**

- Incandescent interior lighting - lights activated by rocker switch mounted above door(s), safety shielded.

**MODEL FEATURES**

- Exterior digital temperature display, available with either °F or °C.
- Evaporator epoxy coated to eliminate the potential of corrosion.
- Backguard improves airflow.
- Minimum wattage heater in cabinet frame and door.
- NSF-7 compliant for open food product.

**ELECTRICAL**

- Unit completely pre-wired at factory and ready for final connection to a 115/60/1 phase, 20 amp dedicated outlet. Cord and plug set included.



**OPTIONAL FEATURES/ACCESSORIES**

Upcharge and lead times may apply.

- 6" (153 mm) standard legs.
- 6" (153 mm) seismic/flanged legs.
- 6" (153 mm) stainless steel legs.
- Stainless steel rail skirt for use with legs (field installed).
- Metal door handles (factory installed).
- Novelty baskets.
- Electronic temperature control (factory installed).
- Correctional facilities options.
- Curb mountable units.
- Remote cabinets (condensing unit supplied by others; system comes standard with 404A expansion valve and requires R404A refrigerant). Consult factory technical service department for BTU information. All remote units must be hard wired during installation.
- Kit #1: Nine (9) sets of #1 type tray slides and pilasters (factory installed), bottom support of one (1) 18"L x 26"D (458 mm x 661 mm) pan or two (2) 14"L x 18"D (356 mm x 458 mm) pans.
- Kit #2: One (1) set half-section #2 steel rod tray slides and pilasters (factory installed), rim support of one (1) 18"L x 26"D (458 mm x 661 mm) pan.
- Kit #3: Six (6) sets of universal type tray slides and pilasters (factory installed), bottom support of one (1) 18"L x 26"D (458 mm x 661 mm) pan, two (2) 14"L x 18"D (356 mm x 458 mm) pans or two (2) 12"L x 20"D (305 mm x 508 mm) pans.
- Kit #4: Three (3) chrome shelves 23 1/2"L x 27 3/4"D (597 mm x 705 mm). Four (4) shelf supports included per shelf (factory installed); adjustable on 6" (153 mm) increments. Optional wall mounted shelf support pilasters (factory installed) with four (4) shelf clips per shelf available; adjustable on 1/2" (13 mm) increments.
- Additional kit option components available individually. Upcharge applies.

**PLAN VIEW**

CUBIC FEET 56

\* Based on ANSI/AHAM HRF-1-2004

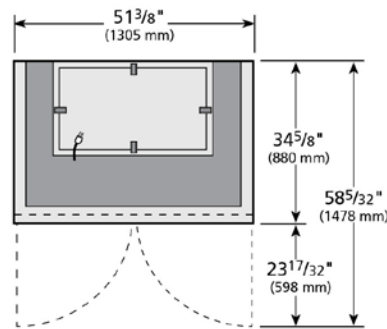
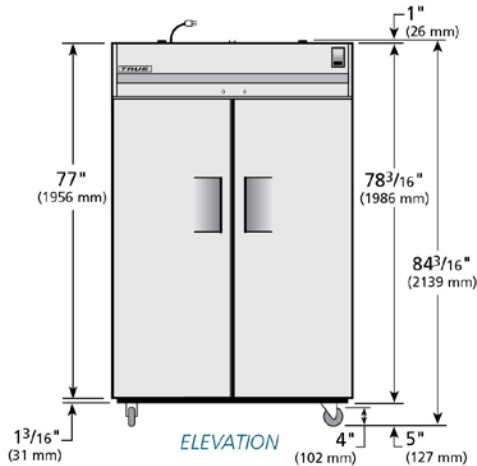

**WARRANTY**  
One year warranty on all parts and labor and an additional 4 year warranty on compressor. (U.S.A. only)

METRIC DIMENSIONS ROUNDED UP TO THE NEAREST WHOLE MILLIMETER  
SPECIFICATIONS SUBJECT TO CHANGE WITHOUT NOTICE

	Model	Elevation	Right	Plan	3D	Back
	TR2F-2S	TFQY54E	TFQY54S	TFQY54P	TFQY543	

**TRUE FOOD SERVICE EQUIPMENT**

2001 East Terra Lane • O'Fallon, Missouri 63366 • (636)240-2400 • Fax (636)272-2408 • (800)325-6152 • Intl. Fax# (001)636-272-7546 • www.truemfg.com