



TRUE FOOD SERVICE EQUIPMENT, INC.

2001 East Terra Lane • P.O. Box 970 • O'Fallon, Missouri 63366
 (636)240-2400 • Fax (636)272-2408 • (800)325-6152 • Intl Fax# (001)636-272-7546
 Parts Dept. (800)424-TRUE • Parts Dept. Fax# (636)272-9471 • www.truemfg.com

Project Name: _____

Location: _____

Item #: _____ Qty: _____

Model #: _____

A/A #

S/S #

Model:
TUC-27-LP

Undercounter:
Low Profile Solid Door Refrigerator



TUC-27-LP

- ▶ Designed using the highest quality materials and components to provide the user with colder product temperatures, lower utility costs, exceptional food safety and the best value in today's food service marketplace.
- ▶ "Low Profile" models are designed to slide easily under custom built countertops.
- ▶ 1½" (39 mm) diameter dual swivel castors. 31⅞" (810 mm) work surface height.
- ▶ Oversized, factory balanced, refrigeration system holds 33°F to 38°F (.5°C to 3.3°C).
- ▶ All stainless steel front, top and cabinet ends. Matching aluminum finished back.
- ▶ Attractive, NSF approved, white aluminum interior liner with 300 series stainless steel floor.
- ▶ Self closing door(s). Positive seal, torsion type closure system.
- ▶ Foamed-in-place using Ecomate. A new, innovative, high density, polyurethane insulation that has zero ozone depletion potential (ODP) and zero global warming potential (GWP).

ADA & Low Profile Comparison



1½" diameter dual swivel castors for "LP" models.

ROUGH-IN DATA

Specifications subject to change without notice.
 Chart dimensions rounded up to the nearest 1/8" (millimeters rounded up to next whole number).

Model	Doors	Capacity (Cu. Ft.) (liters)	Shelves	Cabinet Dimensions (inches) (mm)			Counter Height	HP	Voltage	Amps	NEMA Config.	Cord Length (total ft.) (total m)	Crated Weight (lbs.) (kg)
				L	D†	H*							
TUC-27-LP	1	6.5 185	2	27⅞ 702	30⅞ 766	29¾ 756	31⅞	⅙ ¼	115/60/1 230-240/50/1	3.9 2.9	5-15P ▲	7 2.13	180 82

† Depth does not include 1" (26 mm) for rear bumpers.
 * Height does not include 2⅞" (54 mm) for castors.

▲ Plug type varies by country.



Printed in U.S.A.

APPROVALS:

AVAILABLE AT:

Model:
TUC-27-LP

Undercounter:
Low Profile Solid Door Refrigerator



STANDARD FEATURES

DESIGN

- True's undercounter's are designed with enduring quality and value that protects your long term investment. Our commitment to using the highest quality materials and oversized refrigeration ensures exceptional food preservation.
- "Low Profile" models are designed to slide easily under custom built countertops.

REFRIGERATION SYSTEM

- Factory engineered, self-contained, capillary tube system using environmentally friendly (CFC free) 134A refrigerant.
- Oversized, factory balanced refrigeration system with guided airflow to provide uniform product temperatures.
- Extra large evaporator coil balanced with higher horsepower compressor and large condenser maintains cabinet temperatures of 33°F to 38°F (5°C to 3.3°C) for the best in food preservation.
- Sealed, cast iron, self-lubricating evaporator fan motor(s) and larger fan blades give True undercounter units a more efficient low velocity, high volume airflow design. This unique design ensures faster temperature recovery and shorter run times in the busiest of foodservice environments.
- Condensing unit access located in back, slides out for easy maintenance.

CABINET CONSTRUCTION

- Exterior - 300 series stainless steel top, front and sides with matching aluminum back.
- Interior - attractive, NSF approved, white aluminum liner. 300 series stainless steel floor with coved corners.

- Insulation - entire cabinet structure and solid door are foamed-in-place using Ecomate. A new, innovative, high density, polyurethane insulation that has zero ozone depletion potential (ODP) and zero global warming potential (GWP).
- 1½" (39 mm) diameter dual swivel castors permits easy placement. 31⅞" (810 mm) work surface height.

DOOR

- Stainless steel exterior with white aluminum liner to match cabinet interior.
- Two (2) adjustable, heavy duty PVC coated wire shelves 23¼"L x 16"D (591 mm x 407 mm). Four (4) chrome plated shelf clips included per shelf.
- Positive seal self-closing door(s) with 90° stay open feature. Door(s) swing within cabinet dimensions.
- Magnetic door gasket(s) of one piece construction, removable without tools for ease of cleaning.

SHELVING

- Two (2) adjustable, heavy duty PVC coated wire shelves 23¼"L x 16"D (591 mm x 407 mm). Four (4) chrome plated shelf clips included per shelf.
- Shelf support pilasters made of same material as cabinet interior; shelves are adjustable on ½" (13 mm) increments.

MODEL FEATURES

- Evaporator is epoxy coated to eliminate the potential of corrosion.
- NSF-7 compliant for open food product.

ELECTRICAL

- Unit completely pre-wired at factory and ready for final connection to a 115/60/1 phase, 15 amp dedicated outlet. Cord and plug set included.



115/60/1
NEMA-5-15R

OPTIONAL FEATURES/ACCESSORIES

Upcharge and lead times may apply.

- 230 - 240V / 50 Hz.
- Barrel lock (factory installed).
- Additional shelves.
- 30" (762 mm) deep, ½" thick (13 mm), white polyethylene cutting board.
- 30" (762 mm) deep, ½" thick (13 mm), composite cutting board.
- Heavy duty 16 gauge tops.
- Exterior rectangular digital thermometer (factory installed).
- Standard height units with 5" (127 mm) diameter castors. 36" (915 mm) work surface height.
- ADA compliant models with 34" (864 mm) work surface height.

PLAN VIEW

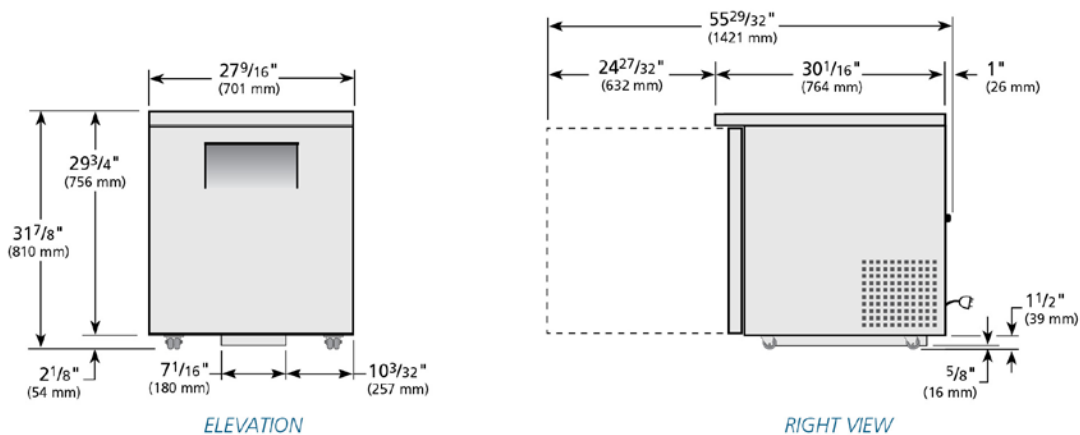

WARRANTY
One year warranty on all parts and labor and an additional 4 year warranty on compressor. (U.S.A. only)

METRIC DIMENSIONS ROUNDED UP TO THE NEAREST WHOLE MILLIMETER
SPECIFICATIONS SUBJECT TO CHANGE WITHOUT NOTICE



Model	Elevation	Right	Plan	3D	Back
TUC-27-LP	TFQY101E	TFQY101S	TFQY01P	TFQY1013	

TRUE FOOD SERVICE EQUIPMENT