

Continental



Refrigerator

SLIM LINE REFRIGERATORS

- 15 Cu. Ft. - 17³/₄" Wide
- 30 Cu. Ft. - 36¹/₄" Wide

Utilizing Environmentally Safe, CFC-free R-134a Refrigerant



1RSE
(shown with optional 12 x 20 pans)

2RSE

Standard Features

- Modern, State-of-the-Art Styling
- Performance Rated Refrigeration System Utilizing Environmentally Safe R-134a Refrigerant
- High Density Non-CFC Polyurethane Foamed-In-Place Insulation
- Will Accommodate 12 x 20 Pans
- Chrome Plated Flow Line Handles
- Cam-Action Lift-Off Hinges
- Self-Closing Doors
- Automatic Interior Lighting
- Magnetic Snap-In Door Gasket
- Field Rehingable Doors (model 1RSE only)
- Automatic Electric Condensate Evaporator
- 5" Casters
- Heavy-Duty, Epoxy-Coated Steel Shelves
- External Dial Thermometer
- Cylinder Lock In Each Door

Standard - (S/S Front, Aluminum End Panels & Interior)

Suffix SA - (S/S Exterior, Aluminum Interior)

Suffix SS - (S/S Exterior & Interior)

Models Available

- Remote
- Half Door
- Shallow Depth (2 Sec. Model Only)
- Pass-Thru (2 Sec. Model Only)

Optional Features & Accessories

- Legs
- Stainless Steel Case Back
- Increased Refrigeration Systems
- Stainless Steel Shelves
- Digital Thermometer
- Rehinging of Doors





REFRIGERATORS

SPECIFICATIONS

DIMENSIONAL DATA

	1RSE One Section Reach-In	2RSE Two Section Reach-In
Net Capacity (cu.ft.)	15	30
Width Overall (in.)	17 3/4	36 1/4
Depth Overall (Incl. Hlds.) (in.)	35 1/2	35 1/2
Depth (Less Door(s) (in.)	32	32
Depth (Door(s) Open 90°) (in.)	47 3/8	48 1/2
Clear Door Width (in.)	13 3/4	12 5/8
Clear Full-Door Height (in.)	61 1/4	58 5/8
Clear Half-Door Height (in.)	30 7/8	N/A
Height, Overall (Incl. 5" Casters) (in.)	82 1/4	82 1/4
No. of Full Door(s)	1	2
No. of Half Door(s)	2	N/A
No. of Shelves	4	3
Shelf Area (sq. ft.)	9.3	24.4

REFRIGERATION DATA

Condensing Unit Size (H.P.)	1/4	1/4
Capacity (BTU/Hr.)*	1940	2190

ELECTRICAL DATA

Cabinet Specifications	115/60/1	115/60/1
Feed Wires (Incl. Ground)	3	3
Condensing Unit Specs	115/60/1	115/60/1
Total Amperes	6.5	7.1
Cabinet Amperes	1.6	1.8
Defrost Amperes	-	-
Power Supply Cord	yes	yes

SHIPPING DATA

Height – crated (in.)	83	82
Width – crated (in.)	32	42
Depth – crated (in.)	42	42
Volume – crated (cu. ft.)	65	84
Weight Std – crated (lbs.)	290	430
Weight SS – crated (lbs.)	350	490
Weight Std – uncrated (lbs.)	190	330
Weight SS – uncrated (lbs.)	250	390

*Rating @ +25°F Evaporator, 90° Ambient

Note: All specifications subject to change without notice.

Note: If the cabinet is located directly against wall and/or under low ceiling, a minimum clearance of 2" is required.

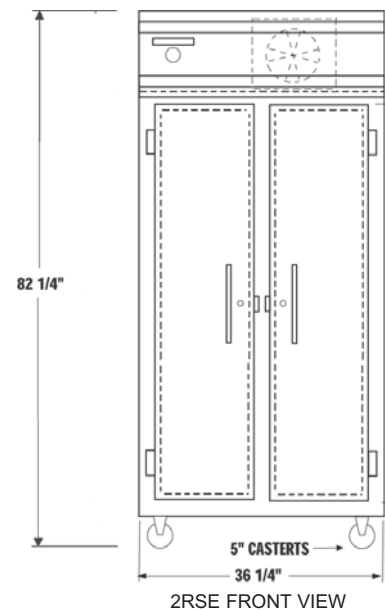
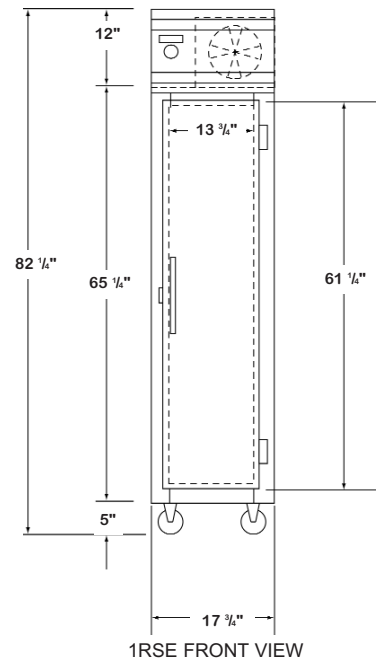
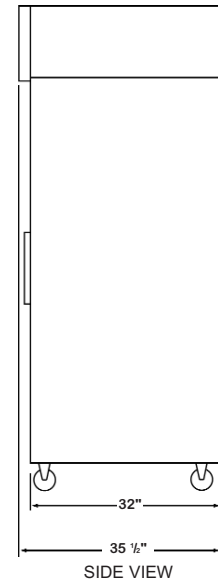

Continental
Refrigerator

A Division of National Refrigeration & A/C Products, Inc.
539 Dunksferry Road Bensalem, PA 19020
(800) 523-7138 Fax: (215) 244-9579
www.continentalrefrigerator.com