



S1828E

MODEL S1828E Electric Conveyor Oven



Project _____

Item No. _____

Quantity _____

All data is shown per oven section, unless otherwise indicated.
Blodgett electric conveyor oven with 18" (457mm) wide belt and 28" (711mm) baking zone length. Single, double, or triple stack models are available.

OPTIONS AND ACCESSORIES

(AT ADDITIONAL CHARGE)

- Stainless steel legs with casters, two with brakes
 - 25" (635) tall with stainless steel undershelf for single and double stack
 - 12" (305) tall for triple stack
- Turnkey installation
- 6' cord with NEMA 15-50P plug for 208V or 240V, 3 phase ovens
- One year additional extended warranty*

STANDARD FEATURES

- Energy efficient heating system that improves cooking results and saves energy
- Solid state controls out of the heat zone
- Temperature controller's built in auto tune feature improves overall conveyor oven performance
- Microprocessor-controlled conveyor speed with motor feedback
- Stackable to three high
- Removable conveyor frame and belt assembly
- 4" (102mm) legs for counter top units
- Removable 6" (152mm) and 12" (305mm) stainless steel extension
- Adjustable conveyor belt tension
- Field reversible conveyor belt direction
- One year parts and labor warranty
- Start Up by our Authorized Service Provider to activate the warranty (USA and Canada only)*

EXTERIOR CONSTRUCTION

- Stainless steel front, sides, top and interior
- Easy serviceable access to all components
- Exterior top and front surfaces are cool to the touch
- Full drop down front window
- Fully insulated on bottom, top, front and rear.

INTERIOR CONSTRUCTION

- Stainless steel outer (finger) plates
- 18" (457mm) wide stainless steel wire mesh conveyor belt
- 28" (711mm) long bake chamber
- Two single inlet blowers behind the heat source for forced air circulation, supplying top and bottom air flow
- Standard or Customer specific finger set that allows control of 8 heat zones inside the bake chamber. Finger set consists of manifolds, inner plates, outer plates and blank plate(s)

OPERATION

- Solid state digital controls to display set point and actual bake chamber temperature(s) as well as bake time.
- Maximum Temperature is 550 degrees F (one degree increment)
- 1:00 - 30:00 minute bake time (one second increment)
- Two blower motors with thermal overload protectors
- Product clearance 3 1/2" (889mm)
- Heat transferred through forced directed hot air impingement
- Open vented baking chamber
- Electrical resistance heating element
- One blower cooling fan
- Easy to clean – no tools required



* For all international markets, contact your local distributor.

BLODGETT OVEN COMPANY

www.blodgett.com

1400 Toastmaster Drive, Elgin, IL USA 60120 • Phone: (847) 741-3300 • Fax: (847) 741-0015



MODEL S1828E

FLOOR UNIT APPLICATION (LEGS & CASTERS)

DIMENSIONS ARE IN INCHES (MM)

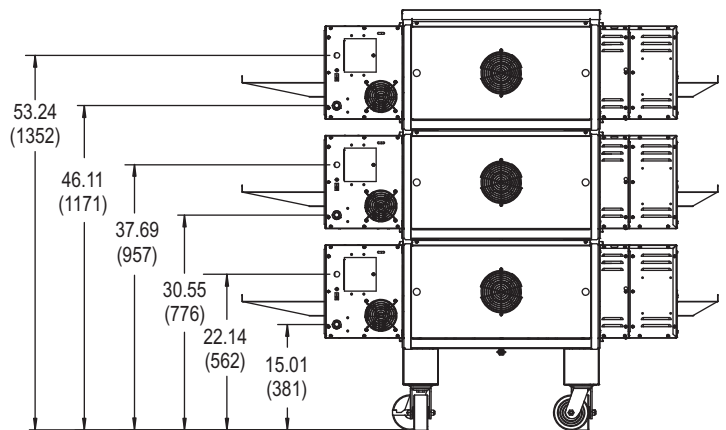
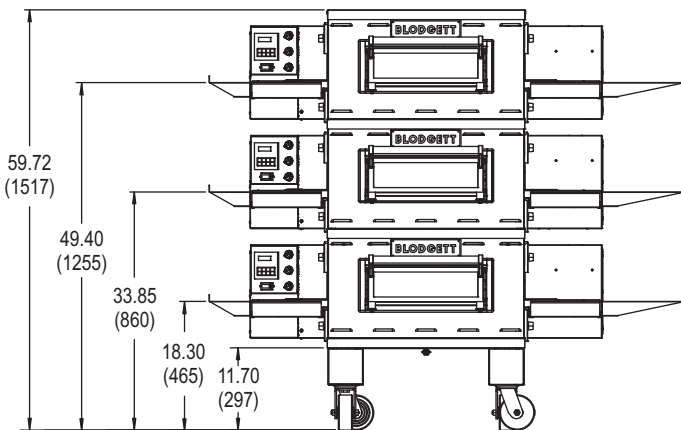
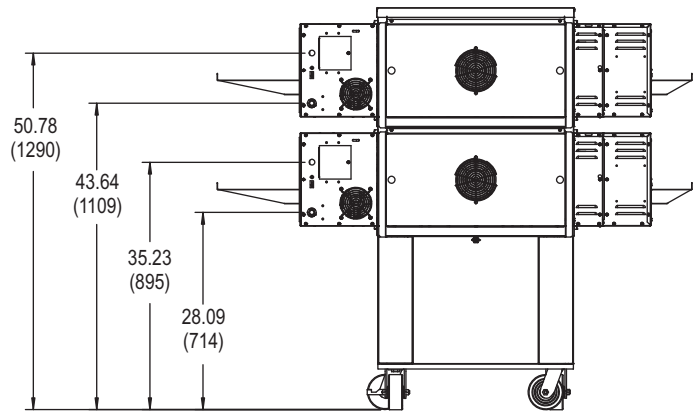
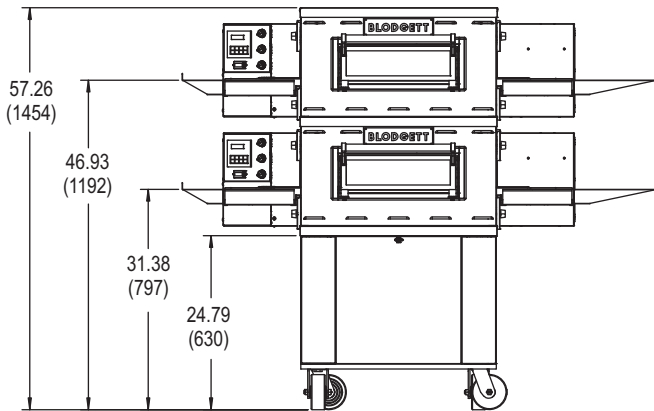
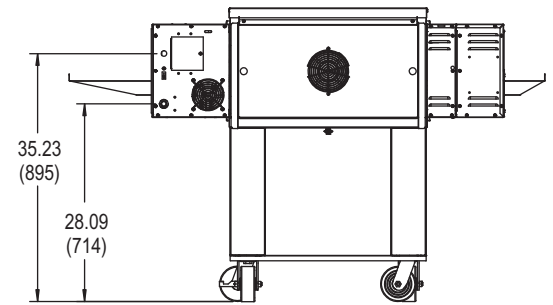
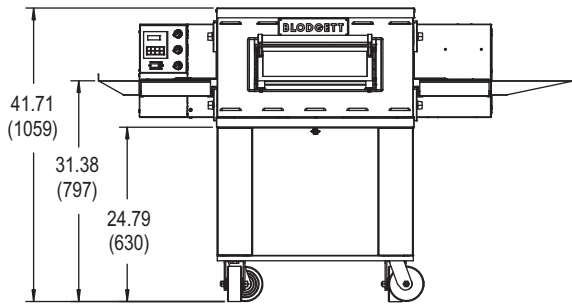
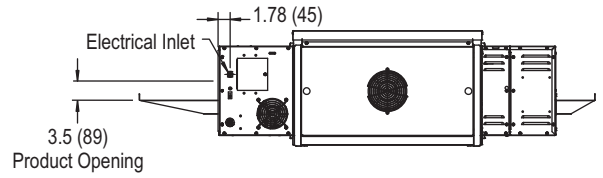
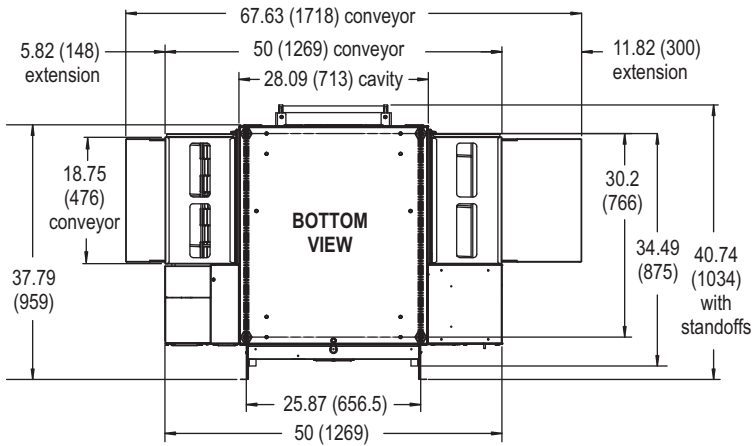

BLODGETT OVEN COMPANY

www.blodgett.com

1400 Toastmaster Drive, Elgin, IL USA 60120 • Phone: (847) 741-3300 • Fax: (847) 741-0015



MODEL S1828E

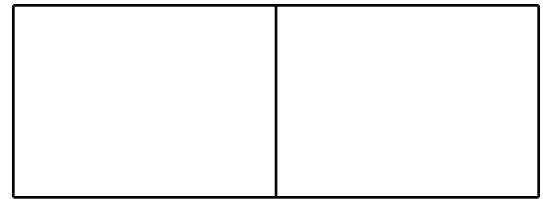

APPROVAL/STAMP

COUNTERTOP APPLICATION

DIMENSIONS ARE IN INCHES (MM)

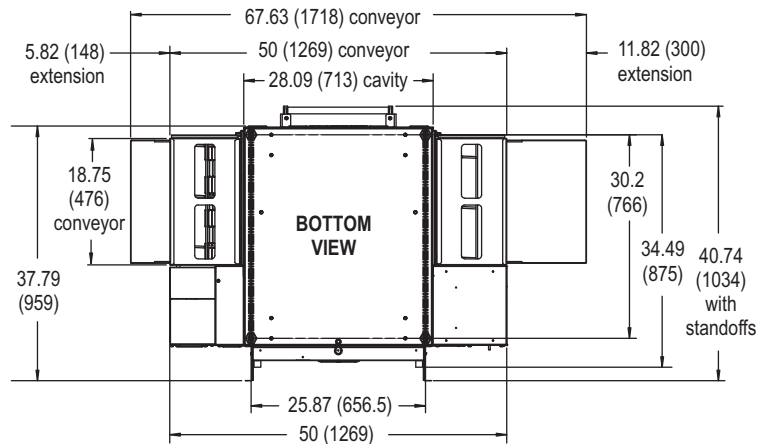
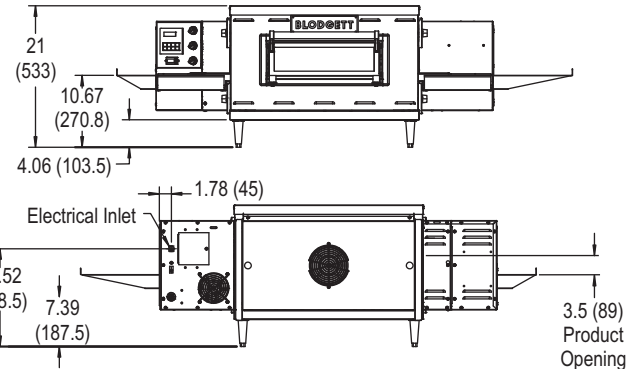
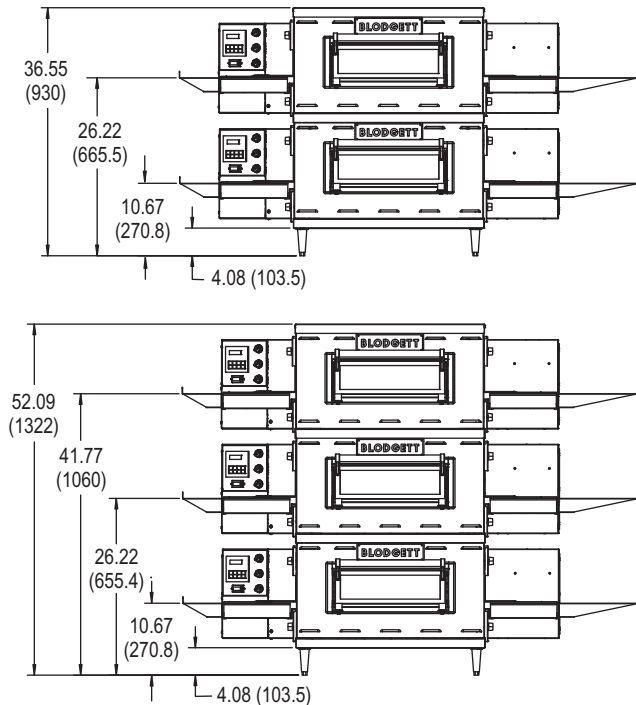

SHORT FORM SPECIFICATIONS

Provide Blodgett model S1828E conveyor oven. Unit shall be electrically heated and shall cook by means of forced, heated air. Unit shall be (single/double/triple) deck supported by (specify stand type from options list). Each deck shall be fully independent, of stainless steel construction, and fully insulated on bottom, top, front and rear. Provide with electrically heated baking compartment with two blowers to evenly distribute heat across baking zone. Conveyor belt shall be 18" (457mm) wide and constructed of stainless steel wire mesh; baking zone length shall be 28" (711mm). Side mounted control panel shall be solid state with 550°F (288°C) maximum thermostat and digital display of adjustable belt speed. Provide options and accessories as indicated.

DIMENSIONS:

Floor space	40.74" (1034mm) W x 50" (1269mm) L
Product clearance	3-1/2" (89mm)
Recommended minimum wall clearance	0" (0mm) left side, right side and rear
Belt width	18" (455mm)
Baking zone length	28" (711mm)

POWER SUPPLY: (must have dedicated ground)

V.A.C.	3 phase models	1 phase models
DOMESTIC		
208 (4 wires)	50/60 Hz, 12.0KW, 35.3 amp	50/60 Hz, 10.0KW, 48.1 amp
240 (4 wires)	50/60 Hz, 12.0KW, 28.8 amp	50/60 Hz, 10.0KW, 41.7 amp
480 (5 wires*)	50/60 Hz, 12.0KW, 14.4 amp	n/a

* Neutral required

CE MODEL

230/240	Contact factory
230/400	Contact factory
380	Contact factory

MAXIMUM INPUT:

Single	12.0 KW, 3 Phase	10.0 KW, 1 Phase
Double	24.0 KW, 3 Phase	20.0 KW, 1 Phase
Triple	36.0 KW, 3 Phase	30.0 KW, 1 Phase

MINIMUM ENTRY CLEARANCE:

Uncrated 18" (457mm)

SHIPPING INFORMATION:

Approx. Weight:

Single:	450 lbs. (204 kg)
Double:	900 lbs. (408 kg)
Triple:	1,350 lbs. (612 kg)

Crate sizes:

Contact factory

NOTE: Blodgett Oven, in accord with its policy to continually improve its products, reserves the right to change materials or specifications without notice. Such revisions do not entitle the buyer to corresponding changes, improvements, additions, or replacements for previously purchased equipment.

BLODGETT OVEN COMPANY

www.blodgett.com • 1400 Toastmaster Drive, Elgin, IL USA 60120 • Phone: (847) 741-3300 • Fax: (847) 741-0015