

# K SERIES



High Temperature Sanitizing Rack Conveyor Dishwashers  
(USA Version)

## OWNER'S INSTALLATION, OPERATION AND MAINTENANCE MANUAL

### *Models:*

- K-44E, K-44ET, K-44S, K-44ST
- K-54E, K-54ET, K-54S, K-54ST
- K-64E, K-64ET, K-64S, K-64ST
- K-66E, K-66ET, K-66S, K-66ST
- K-76E, K-76ET, K-76S, K-76ST
- K-86E, K-86ET, K-86S, K-86ST
- K-80E, K-80ET, K-80S, K-80ST
- K-90E, K-90ET, K-90S, K-90ST
- K-100E, K-100ET, K-100S, K-100ST



## TABLE OF CONTENTS

1. INTRODUCTION .....	3	3.13 Connecting Chemical Containers or Dispensers .....	11
1.1 Overview of Equipment .....	3	3.14 Fresh Water Supply Connection(s).....	11
1.2 General Safety Information.....	3	3.15 Steam System Connections .....	12
2. TRANSPORT AND SHIPPING .....	3	3.16 Drain Connection .....	12
3. INSTALLATION .....	4	3.17 Final Assembly .....	13
3.1 Overview of Installation .....	4	4. OPERATION .....	14
3.2 Requirements Before Installation .....	4	4.1 Location and Description of Controls .....	14
3.3 Uncrating, Positioning and Leveling .....	5	4.2 Startup .....	15
3.4 Tabling Attachment .....	6	4.3 Loading .....	16
3.5 Vent Cowl Collars (if so equipped) .....	6	4.4 Operation .....	17
3.6 Booster Heater Placement .....	7	4.5 Clearing Jams .....	17
3.7 Accessing the Utility Connections .....	7	4.6 Shutdown .....	17
3.8 Main Electrical Supply Connection .....	8	5. CLEANING .....	18
3.9 Dispensing System Overview .....	8	5.1 Daily Cleaning (or as required) .....	18
3.10 Installing an External Solid or Liquid Detergent System .....	9	5.2 Weekly Cleaning (or as required) .....	18
3.11 Installing an External Liquid Rinse Aid System .....	9	5.3 Exterior Cleaning (as required) .....	20
3.12 Wiring External Chemical Dispensing Systems .....	10	5.4 Deliming (as required) .....	20
		6. TROUBLESHOOTING .....	21

AN ELECTRICAL WIRING DIAGRAM IS LOCATED INSIDE THE CONTROL BOX OF THIS MACHINE.

MEIKO K-SERIES RACK CONVEYOR DISHWASHERS HAVE BEEN DESIGNED EXCLUSIVELY FOR THE WASHING OF DISHES, GLASSWARE, CUTLERY, KITCHEN UTENSILS AND TRAYS IN A COMMERCIAL OR INSTITUTIONAL SETTING AND MUST NOT BE USED FOR ANY OTHER PURPOSE WITHOUT THE WRITTEN PERMISSION OF MEIKO.

MEIKO ACCEPTS NO RESPONSIBILITY FOR DAMAGE TO THE APPLIANCE, SURROUNDING EQUIPMENT OR ENVIRONMENT THAT IS CAUSED BY INAPPROPRIATE INSTALLATION OR OPERATION, OR FROM ANY SERVICE THAT IS UNDERTAKEN BY NON-AUTHORIZED PERSONNEL, OR FROM THE USE OF ANY PARTS EXCEPT THOSE THAT ARE APPROVED BY THE MANUFACTURER. ANY SUCH INSTALLATION, USE OR SERVICE WILL IMMEDIATELY VOID THE MANUFACTURER'S WARRANTY.

ANY MODIFICATIONS TO THE APPLIANCE THAT ARE PERFORMED WITHOUT THE WRITTEN PERMISSION OF MEIKO WILL IMMEDIATELY VOID THE MANUFACTURER'S WARRANTY.

Meiko reserves the right to change any specifications without notice at any time.



# 1 INTRODUCTION

## 1.1 Overview of Equipment

Meiko K-series rack conveyors are commercial dishwashers designed for cleaning dishes, glassware, trays, cutlery and kitchen utensils with a minimum of employee intervention or supervision.

A single on/off switch sets the machine into automatic operation. When a rack is pushed into the opening of the machine, the pawl bar drive is activated. Mechanical actuating levers inside the machine are activated by the movement of the rack, automatically activating the prewash (if so equipped), wash and rinse zones.

During idle periods, the wash and rinse are deactivated automatically to conserve water, energy and chemicals, while steam coil or electric tank heaters maintain the water temperature for quick recovery.

Other features of the unit that affect operation include:

**Side-drive system** - Racks are advanced through the machine using pawl bars at the sides of the rack rails. This provides an unobstructed wash pattern.

**Wash arm manifolds** - Wash arms are pre-assembled into easily-removed manifolds for faster cleaning. The nozzles are slotted and concave to minimize clogging. Wash arm end caps are captivated to prevent their loss during cleaning.

**External drain handle(s)** - Pulling on the external handle(s) empties the machine quickly and safely.

**Front-sloping wash tanks** - For faster draining and easier cleaning.

For efficient and SAFE operation, be sure to follow the installation and operating instructions provided in this manual. In particular, all safety symbols and notices on the equipment and in the supplied documentation must be followed.

## **IMPORTANT**

Meiko K-Series rack conveyor dishwashers have been designed exclusively for the washing of dishes, glassware, trays, cutlery and kitchen utensils in a commercial or institutional setting and must not be used for any other purpose.

## 1.2 General Safety Information

The following symbols and headings are used throughout this manual to indicate possible hazards to persons or to the equipment. The symbols and headings are shown in order of importance. The descriptive text following these headings is *italicized* for easy recognition.



**WARNING!** *Possible hazard to persons, such as from electrical shock, crushing, or hot surfaces.*

---

## **CAUTION**

*Possible hazard to the dishwasher or to other equipment.*

---

## **IMPORTANT**

*Vital information or tips for the installer or operator.*

---

## **NOTE**

*Information or tips for the installer or operator.*

---

# 2 TRANSPORT AND SHIPPING

## **IMPORTANT**

- *Observe any notices on the crating material that pertain to shipping.*
- *Use care when transporting the equipment.*
- *As you unpack the equipment, check that all components shown on the shipping invoice are present and intact. Be sure to check for shipping damage. If shipping damage is present, call Meiko Customer Service at 1-800-868-3840, providing full details on the customer, serial number and extent of damage present. Meiko will file a freight claim based on this information.*



**WARNING!** *In NO EVENT should a damaged appliance be installed or operated!*



## 3 INSTALLATION

### 3.1 Overview of Installation

The owner should contract with qualified personnel to move the appliance to the installation location, unpack it, and prepare it for final utility connections. In most cases, local codes prevent the final utility connections from being made by any party other than a licensed electrician, plumber and/or steam fitter.

#### **IMPORTANT**

*It is the responsibility of the owner to ensure that all aspects of the installation comply with all applicable local and national codes.*

#### **IMPORTANT**

*The appliance's warranty is not valid until a Meiko Authorized Service Agent performs a Performance and Installation Inspection.*

Installation of the dishwasher involves the following steps:

- Verifying that the utility connections are present, are appropriate for the appliance, and comply with all applicable local and national codes.
- Unwrapping the appliance (leaving the shipping skid in place for easier movement) and checking for shipping damage.
- Moving the appliance to the installation location, removing the skid, and leveling the feet.
- Connecting the machine to tabling.
- Connecting the machine to a ventilation system (if so equipped).
- Connecting the machine to an external booster heater (if so equipped).
- Connecting the electrical supply.
- Installing the chemical dispensing system (if so equipped), following the manufacturer's instructions AND the instructions in Section 3 of this Manual.
- Connecting the fresh water supply.
- Connecting the steam supply line (for machines with steam heating).
- Connecting the steam condensate return line, and routing it to a floor drain (for machines with steam heating).
- Connecting the drain line, and routing it to a floor drain.

- Contacting your Meiko Authorized Service Agent to perform a Performance and Installation Inspection for the machine. This step also validates the machine's warranty.

### 3.2 Requirements Before Installation

Before the installer can uncrate and move the appliance to the installation location, the following conditions **MUST** be met:

- **INSTALLATION AREA REQUIREMENTS**
  - The area **MUST** be frost-free. Freezing temperatures (32°F/0°C or lower) inhibit proper operation and can damage internal components.
  - The area **MUST** have a firm floor surface. It is possible to compensate for uneven flooring by adjusting the feet.
  - The area should be away from appliances, furniture or surfaces that can be damaged by steam. If this is not possible, these items should be protected from the steam that is released during normal operation of the dishwasher.
- **UTILITY CONNECTION REQUIREMENTS**
  - Connections must be present and ready for hookup to the appliance. All utility supplies must comply with the electrical information labels, with the information on the data plate, and with all applicable local and national codes.
  - Electrical leads, water supply line(s), drain line, and the steam supply and condensate return lines (if so equipped) must be present. The water supply must match the pressure and temperature specified on the data plate. The steam supply (if so equipped) must match the pressure and volume specified on the data plate.
  - For units using an external booster heater, the heater should be installed and ready for connection to the appliance.
  - For units using a chemical dispensing system, appropriate dispensers or containers should be installed and ready for connection to the appliance.
- **GENERAL REQUIREMENTS**

Authorized personnel should be available to perform the actual utility connections.

### 3.3 Uncrating, Positioning and Leveling

1. Remove all shipping and packaging material from the appliance, including supports and wrappings. Leave the shipping skid in place at this time to allow for easier movement to the installation location.
2. Check for shipping damage as described in Section 2, "Transport and Shipping." If damage is present, call Meiko Customer Service at **1-800-868-3840**, providing full details on the customer, serial number and extent of damage present. Meiko will file a freight claim based on this information.
3. Move the appliance to the installation area and remove the skid. Meiko recommends using a pallet truck to lift the entire pallet and avoid damage to the machine. Use caution to avoid damaging the appliance or any of its components.

#### CAUTION

If the pallet is removed, the frame of the dishwasher can be damaged by improper lifting. The machine's weight must always be distributed properly using cross-members to protect the frame.

#### CAUTION

Do not attempt to slide the machine on its feet. This can bend the legs.

4. If dish tables are already in place, it may be necessary to remove the end cowlings to install the machine. To remove the cowlings, refer to Figure 3-1.

Each cowling is held in place by hex head acorn nuts on the inside of the machine. For easy access to the acorn nuts, simply lift the front access door(s).

5. Using a spirit level, check that the appliance is level in both directions (front-to-back AND side-to-side). If necessary, level the appliance by rotating the bottom section of each foot.

#### CAUTION

The dishwasher **MUST** be level for proper operation.

6. If you removed the cowling(s) in Step 4, replace them onto the machine at this time. Be sure to check that the rubber gasket that fits between each cowling and the body of the machine is properly seated.
7. Run a fine bead of clear silicone sealant along the top edge of the seam between each cowling and the machine.

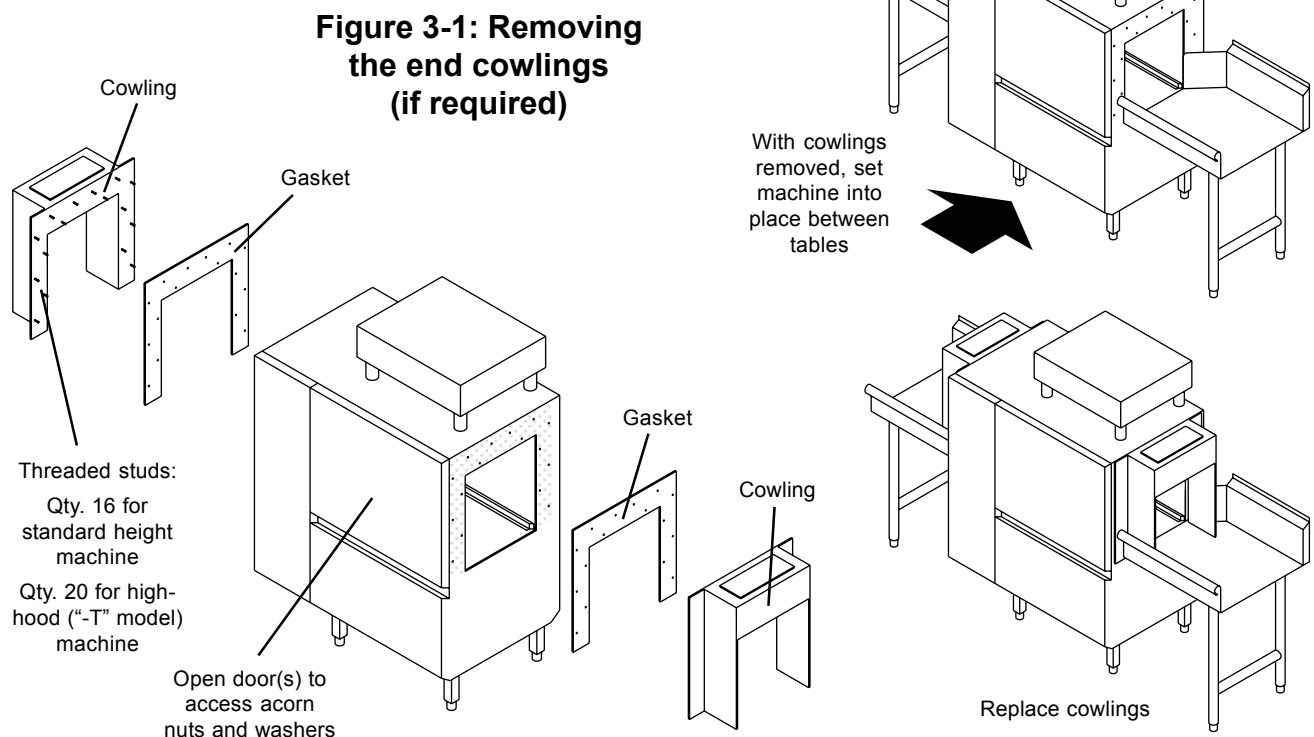

### 3.4 Tabling Attachment

1. Position the table lip-in at both ends of the machine, as shown in Figure 3-2. Be sure to seat the lip-in against the inner plate of the sidewall of the dishwasher.

#### CAUTION

If the table lip-in is forced between the inner and outer plates, it will not seat properly. Always ensure that the lip-in is seated correctly as shown in Figure 3-2.

**Figure 3-2: Tabling attachment**

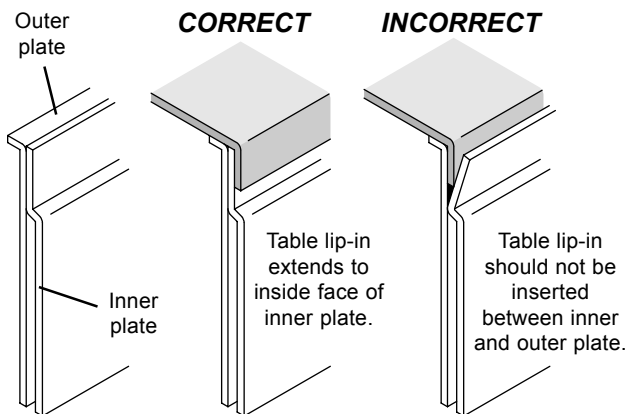

2. Position the dishwasher and tables as follows:

- Check that the centerline at the opening of each table is aligned with the centerline of the rack track of the dishwasher.
- Check that the surface height of each table matches the height of the rack track of the dishwasher, to ensure a smooth transition. The standard table surface height is 34" (864mm).
- Check that the dishmachine is level.

The height of the dishmachine, and of most tables, can be adjusted by rotating the feet at the end of the legs.

#### CAUTION

After adjusting the height of the dishmachine, always check that it is level to ensure proper operation.

3. After the tables have been positioned correctly, secure them to the dishwasher using silicone sealant.

### 3.5 Vent Cowl Collars (if so equipped)

For units that are not equipped with optional vent cowl collars, skip ahead to Section 3.6, "Booster Heater Placement."

1. Check that the ventilation ducts (or "pant legs" are correctly positioned above the vent cowl collars on the machine.
2. Determine how the ducts will be attached. See Figure 3-3.

**Figure 3-3: Vent cowl collar ducting**

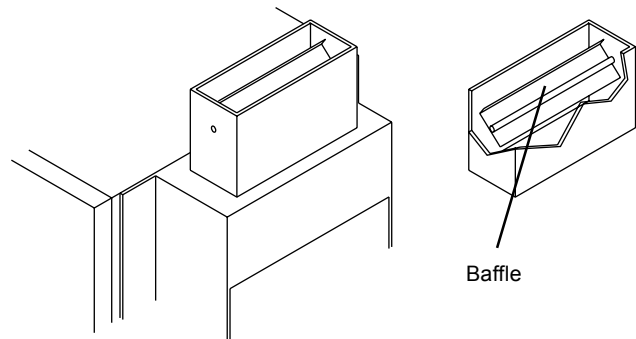

#### DUCT SLEEVED OUTSIDE COLLAR (RECOMMENDED)

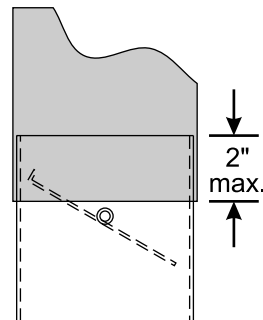

#### DUCT SLEEVED INSIDE COLLAR

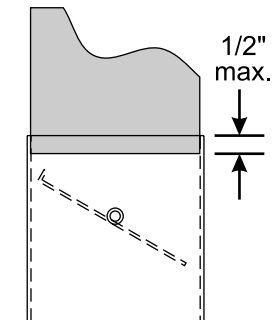

- In most instances, the ducts can be sleeved over the outside of the vent cowl collars. This is the easiest installation and is recommended.

For this installation, the INSIDE DIMENSIONS of the ducting, when viewed from the front of the machine, should be 4" W x 16" D. The duct can overlap the outside of the vent cowl collar by up to 2" without interfering with the operation of the baffle.

- Where required by local codes, the ducts can be sleeved inside the edge of the vent cowl collars.

For this installation, the **OUTSIDE DIMENSION** of the ducting, when viewed from the front of the machine, should be 3-3/4" W x 15-3/4" D. The duct should overlap the inside of the vent cowl collar by a *maximum* of 1/2" to avoid interfering with the baffle.

- Install the ducts to the vent cowl collars.
- Secure the ducts to the collars using silicone sealant.
- The baffles cannot be properly adjusted until the machine is turned on. Refer to Section 3.17, "Final Assembly."

### 3.6 Booster Heater Placement

For units that are not equipped with an external booster heater (for instance, when using a building's boiler as a 180°F water supply), skip ahead Section 3.7, "Accessing the Utility Connections."

The booster heater should be positioned at the unload end of the machine, close to the water inlet access panel. Meiko recommends a maximum pipe length from the booster to the machine's water inlet of 48". If a longer pipe run is necessary, Meiko recommends the use of pipe insulation to minimize heat loss.

### 3.7 Accessing the Utility Connections

The utility connections for the machine are shown in Figure 3-4.

**Figure 3-4: Accessing utility connections**

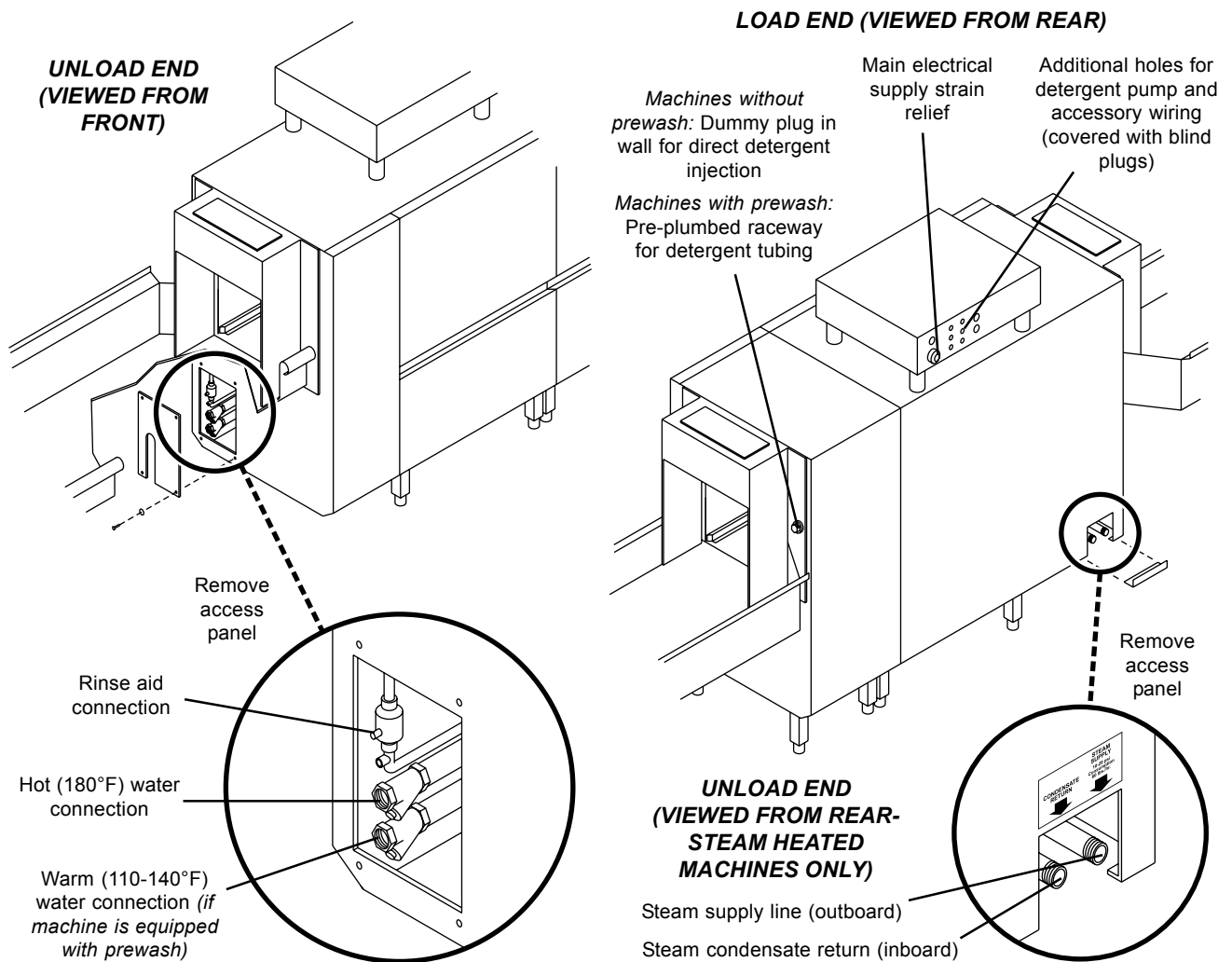

### 3.8 Main Electrical Supply Connection



#### **WARNING!**

Check that the circuit breaker/fused disconnect is in the OFF position and that the unit is switched off before making the electrical utility connections.

#### **IMPORTANT**

In some cases, local codes dictate that electrical supply connections be made only by a certified professional.

1. Check that the incoming power leads are of sufficient rating for the appliance's current draw. Amperage and minimum supply wire specifications are shown on the serial plate and on the electrical information label on the control box.
2. Remove the top cover panel from the electrical control box by removing the four screws that hold it in place.
3. Locate the strain relief for the electrical supply wiring on the back of the control box (Figure 3-4). Thread the incoming supply leads through the strain relief and to the main electrical supply terminal block.
4. Refer to Figure 3-5 and the electrical wiring diagram. Connect the power supply and ground leads as indicated.
5. Adjust the strain relief to fasten the wiring in place. You should leave enough slack in the wiring to prevent stress on the terminal connections.

**Figure 3-5: Main electrical supply connections**

L1, L2 and L3 = "hot" (line)  
GND = ground

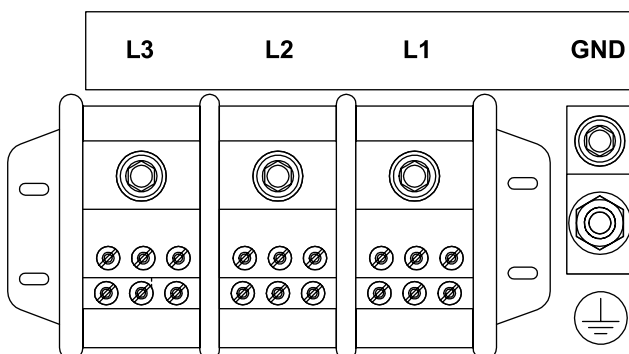

### 3.9 Dispensing System Overview

K-Series rack conveyor dishwashers are designed for use with a liquid rinse additive, and either solid or liquid detergents. Detergent and rinse additive injection is supplied by external dispensing systems (supplied by others).

The machine is equipped with:

- A location for detergent injection at the load end of the machine (see Figure 3-6).
  - Machines equipped with a prewash section (K-66, K-76, K-80, K-86, K-90, K100) have a pre-plumbed tubing raceway exiting the machine at this location. The raceway is routed to deliver detergent into the wash tank. Solid or liquid detergent lines can be routed down the raceway and into the tank.
  - Machines that are NOT equipped with a prewash section (K-44, K-54, K-64), have a dummy plug at this location. Removal of the plug allows the detergent line to be installed for direct chemical injection into the wash tank at this location.
- A dummy plug in the floor of the wash tank that permits the installation of a detergent concentration probe.
- A final rinse plenum chamber with a fitting for a liquid rinse aid line (see Figure 3-7). A threaded pipe connection just below the plenum allows the installation of a final rinse pressure switch.

A dispensing system terminal block inside the control box of the machine provides contacts for two **line voltage** relays. These relays, when closed, provide a "window" for external pump systems to activate.

- A relay labeled "DDC" (Detergent Dispenser Connection) closes whenever the wash pump is in operation. This relay should be used for the detergent dispenser.
- A relay labeled "CVS" (Conveyor Voltage Signal) closes whenever the conveyor drive motor is in operation. This relay should be used for the rinse aid dispenser.



Pump activation can be controlled as follows:

- Solid detergent systems should use a probe installed in the wash tank to measure detergent concentration and allow activation of the external pump. A dummy plug in the bottom of the wash tank provides an installation location for the probe.
- Liquid detergent systems can use EITHER a detergent concentration probe, OR a timer system. A detergent concentration probe is **HIGHLY RECOMMENDED**.
- Liquid rinse aid systems should use a rinse line pressure switch so that rinse aid is dispensed only when the final rinse is in operation. A 1/8" NPT female threaded connection is provided in the rinse aid line just below the final rinse plenum chamber. The pressure switch should be installed at this location.

**Figure 3-6: Detergent connection**

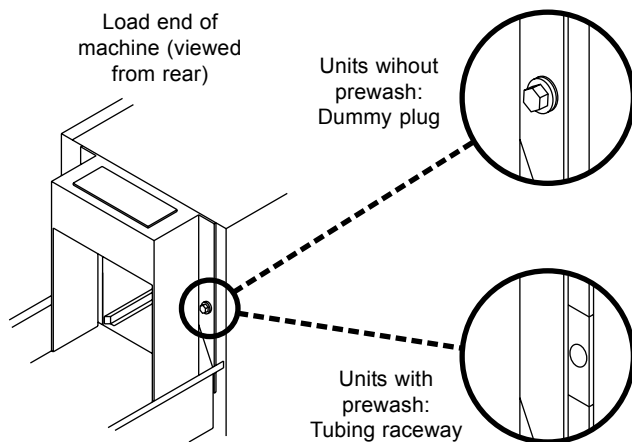

**Figure 3-7: Rinse aid connection**

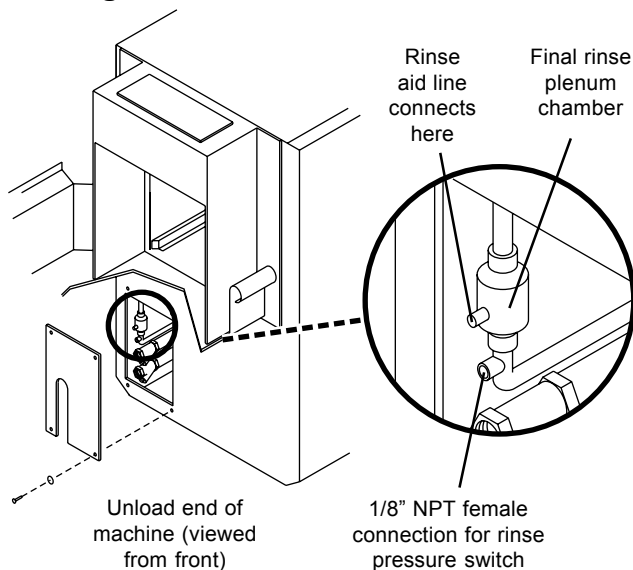

### 3.10 Installing an External Solid or Liquid Detergent System

1. Locate the detergent line connection at the load end of the machine. See Figure 3-6.
  - Machines **WITH** a prewash section (K-66, K-76, K-80, K-86, K-90, K-100) have the open end of a tubing raceway at this location.
  - Machines **WITHOUT** a prewash section (K-44, K-54, K-64) have a dummy plug at this location, covering a direct opening into the wash tank. Remove the plug.
2. Route the detergent supply line to the opening. For machines with a prewash section, route the chemical supply tubing completely down the raceway and into the wash tank.

#### **CAUTION**

*Make sure that the detergent line runs completely down the raceway to the wash tank. The raceway is **NOT** watertight, and is **NOT** intended to be a tube for chemicals!*

3. Fasten the line in place and seal the connection.
4. If a detergent concentration probe will be used, remove the dummy plug in the bottom of the wash tank. Then, install the detergent concentration probe and seal the connection.
5. Check that the pump is correctly installed according to the manufacturer's instructions.

### 3.11 Installing an External Liquid Rinse Aid System

1. Route the rinse aid supply line to the fitting on the side of the final rinse plenum chamber and fasten it in place. See Figure 3-7. Check that the connection is secure and seal it.
2. Install a rinse pressure switch to the 1/8" NPT female pipe connection just below the final rinse plenum chamber. See Figure 3-7.
3. Check that the pump is correctly installed according to the manufacturer's instructions.

### 3.12 Wiring External Chemical Dispensing Systems

Figure 3-8: Chemical dispenser circuit breakers

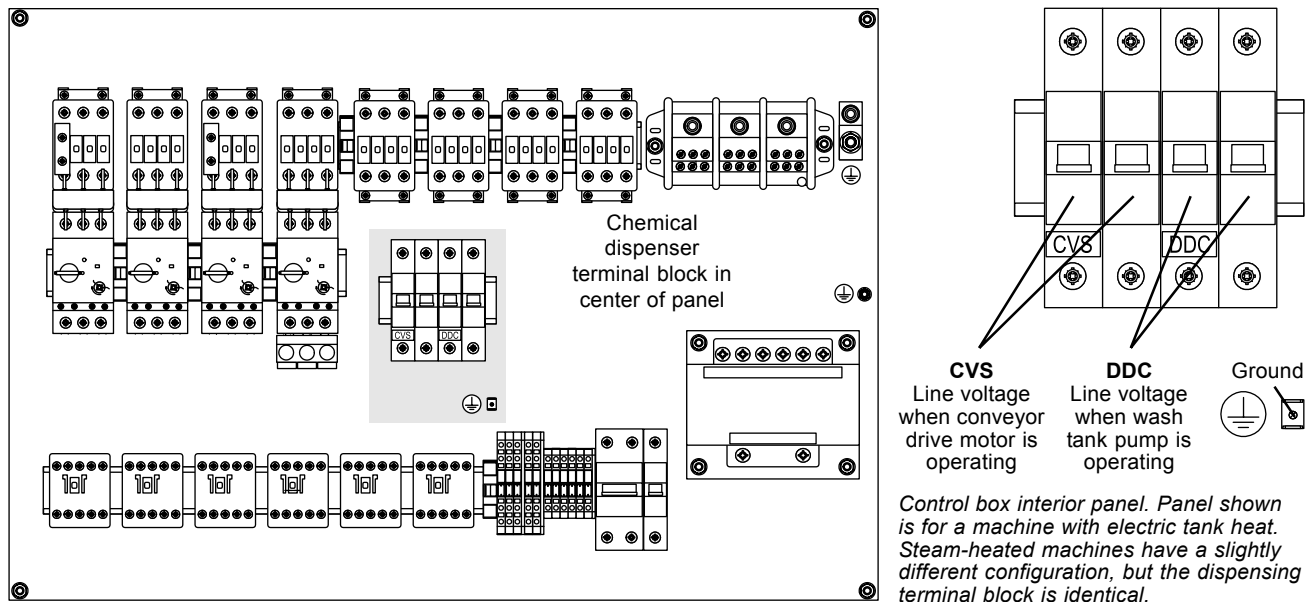

#### IMPORTANT

Some local codes dictate that electrical connections be made only by a certified professional.

1. Locate the chemical dispenser circuit breakers inside the control box of the machine. See Figure 3-8.
2. Thread the incoming leads from the chemical pumps through the extra strain reliefs (on the back side of the control box; see Figure 3-9) and to the chemical dispenser circuit breakers.
3. Connect the wiring for the external chemical dispensing system(s) as follows:
  - The terminals marked “**DDC**” (Detergent Dispenser Connection) provide a **line voltage** signal to the external detergent pump. This supply is present **ONLY** when the wash pump is operating. These terminals should be used to supply power to the detergent dispenser.
  - The terminals marked “**CVS**” (Conveyor Voltage Signal) provide a **line voltage** power supply for the external dispensing equipment. This supply is present whenever the conveyor drive motor is in operation. These terminals should be used to supply power to the rinse aid dispenser.
4. Adjust the strain reliefs to fasten the wiring in place. Leave enough slack in the wiring to prevent stress on the connections, and bundle them together using wire ties.

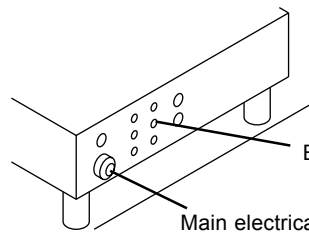

Figure 3-9:  
Strain reliefs

### 3.13 Connecting Chemical Containers or Dispensers

*This section applies to units with either internal or external chemical dispensing pumps.*

1. Check that the rinse additive and detergent are compatible with the unit. In particular, a commercial (not a domestic) detergent **MUST** be used.
2. Check that the containers/dispensers are correctly installed according to the manufacturer's instructions.

### 3.14 Fresh Water Supply Connection(s)

#### CAUTION

*Before connecting the water supply line, it **MUST** be flushed clean of all debris, including (but not limited to) pipe sealant, metal particles, solder, etc. This debris can damage the appliance.*

#### IMPORTANT

*In some cases, local codes dictate that water supply connections be made only by a certified professional.*

The water supply connection(s) for the dishwasher are located behind an access panel on the unload end of the machine. All connections are 3/4" female NPT. See Figure 3-10.

1. Check that iron or other metal particles cannot contaminate the fresh water supplied to the dishwasher.

**Figure 3-10: Water connections**

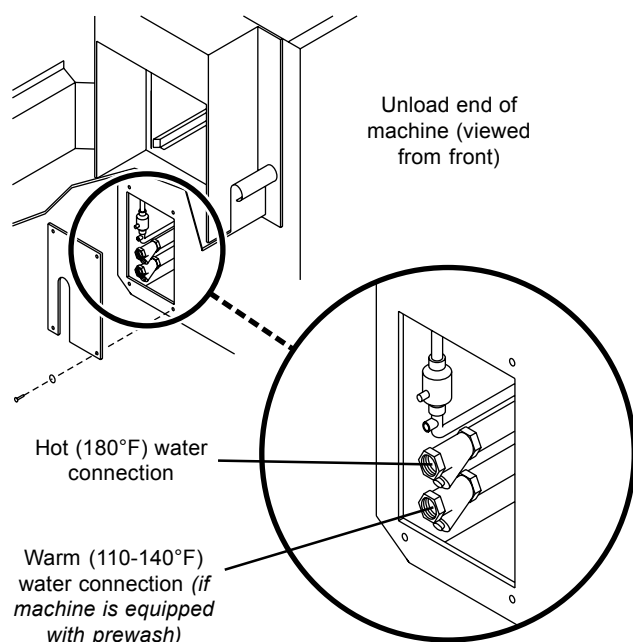

2. Check the incoming water temperature.
  - Units without a prewash section (K-44, K-54, K-64) have one incoming water connection, which must be 180°F.
  - Units with a prewash section (K-66, K-76, K-80, K-86, K-90, K-100) have two incoming water lines. The line for the final rinse connection must be 180°F. The line for the prewash connection must be 110-140°F.
3. Check the incoming water hardness. Meiko recommends a hardness of 4-6 grains per U.S. gallon (7 DH German hardness).
4. Because the water inlet incorporates a stainless steel dirt trap, an additional trap is unnecessary unless required by local, national or international codes.
5. Connect the customer-supplied water line(s) to the appropriate connection(s). Fill line connections are 3/4" NPT female.
6. Check the incoming water pressure at the final rinse pressure gauge, as shown in Figure 3-11. The machine requires a pressure of 15-25 psi at the final rinse for correct operation. It may be necessary to increase the pressure (with a booster pump) or to reduce the pressure (with a reducing valve).

**Figure 3-11: Final rinse pressure**

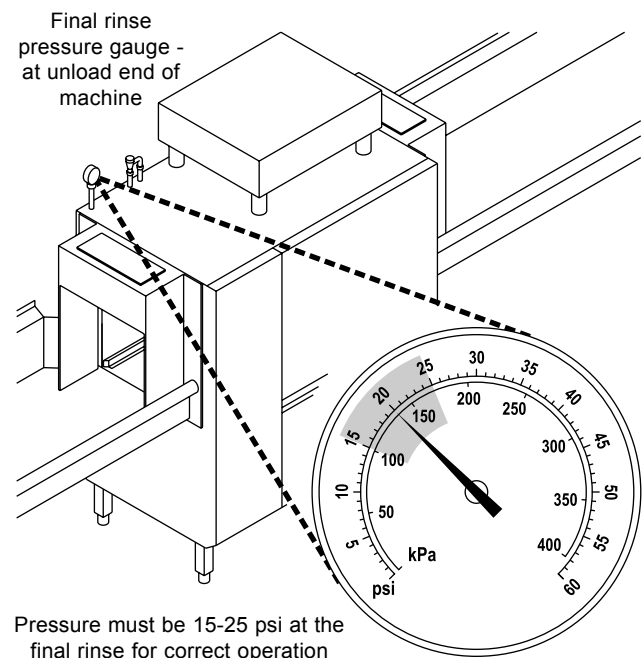

### 3.15 Steam System Connections

#### **IMPORTANT**

*In some cases, local codes dictate that steam system connections be made only by a certified professional.*

The steam supply and condensate return connections are located behind an access panel on back wall of the machine, at the unload end. Both connections are 3/4" male NPT. See Figure 3-12.

If the machine is against a wall, you can remove the water connection access panel to reach the steam supply and condensate return connections, as shown in Figure 3-10 on the previous page.

The steam supply connection is on the outboard side (closest to the end of the machine). The condensate return is on the inboard side (further away from the end of the machine).

Note that the condensate return is only for the steam system of the dishmachine. A steam booster heater, or a steam supply line with an upward slope, will require individual condensation removal systems (moisture trap, pump, etc.) that are in compliance with all applicable local codes.

1. Check the incoming steam pressure. At the machine connection, pressure should be 10-29 psi and **constant**.
2. Check that the volume of steam delivered is sufficient for proper operation. The dishmachine requires 60 lbs./hr. of steam at 10-29 psi (not including an external steam booster heater, if one is present).
3. Connect the customer-supplied steam line to the machine's steam connection. The machine's connection is 3/4" NPT male.
4. Plumb the condensate return connection to a floor drain as per local codes. The machine's condensate return connection is 3/4" NPT male.

### 3.16 Drain Connection

#### **IMPORTANT**

*In some cases, local codes dictate that drain connections be made only by a certified professional.*

The machine is equipped with a 2-15/16" (75mm) OD vertical, gravity-fed drain. The machine requires a 4" or larger floor drain. See Figure 3-13.

1. In some cases, a grease trap (supplied by others) must be fitted into the waste water line. If a trap is required for your installation, check that it is present.
2. If possible, the machine drain can simply be positioned directly above a floor drain, as shown in Figure 3-13.
3. If a floor drain is not directly beneath the machine drain, or if local codes require a trap, a drain line can be attached using the supplied rubber boot and clamp. Using the boot and clamp, the machine drain can be connected either to a 3" OD drain line, or to a 3" NPT pipe (using the supplied 3" NPT adapter). Choose a piping material that:
  - Complies with any applicable local and national codes.
  - Is rated for use with water temperatures up to 180°F.
  - Is rated for 3-12 pH to accommodate detergents and rinse aid in the drain water.

**Figure 3-12: Steam system connections**

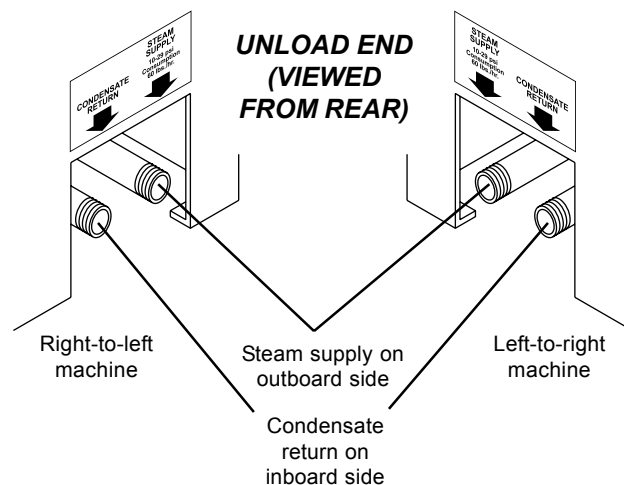

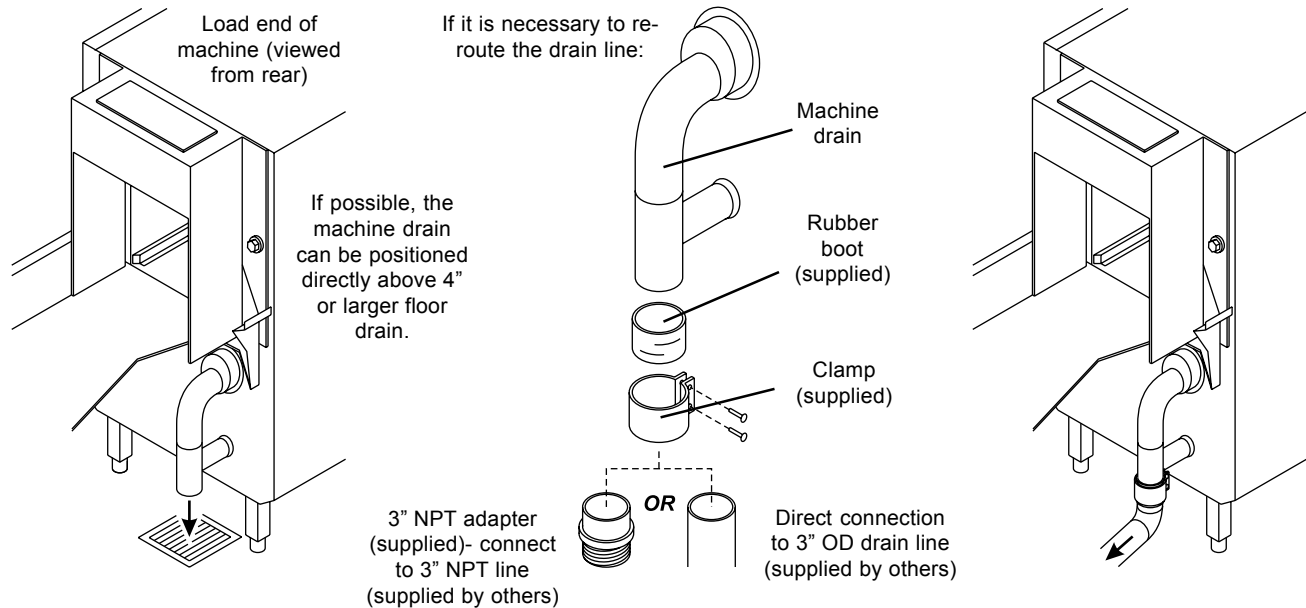
**Figure 3-13: Drain connection**

### 3.17 Final Assembly

1. Check and tighten all electrical terminal screws.
2. Replace all panels onto the warewasher.
3. Check that all tools, hardware, metal shavings or filings, etc. are removed from inside the machine.
4. Check that the wash arm manifolds, scrap screens, curtains, and all other removable components are correctly installed in the machine.
5. Check that the front access door(s) are closed.
6. Switch the circuit breaker/fused disconnect to the ON position.
7. Switch the POWER ON/OFF switch to the ON position. Allow the machine to fill.
8. Load several empty racks into the machine, checking that the racks move smoothly without binding and that the wash and rinse arms (and prewash arms, if so equipped) activate when a rack reaches the zone.
9. Prime the detergent and rinse aid pumps according to the manufacturer's instructions. The chemical installer should check for correct chemical concentration at this time.
10. Adjust the baffles inside the vent cowl collars (if so equipped). Refer to Figure 3-3 (on Page 6). The baffles should be opened just enough to prevent steam from exiting the ends of the machine with the curtains in place.
  11. Allow the racks to exit the machine. Switch the POWER ON/OFF switch to the OFF position. Switch the circuit breaker/fused disconnect to the OFF position.
  12. Pull the external drain handle(s) to empty the machine.
  13. Remove the scrap screens, clean them if they are soiled, and allow them to air dry.
  14. Remove the wash, rinse (and prewash if so equipped) arm manifolds, clean them if necessary, and allow them to air dry.
  15. Access the two water inlets (see Figure 3-4). Check the dirt traps and clean them if necessary.
  16. Replace all components into the dishwasher. The machine is now ready for regular operation.

#### **IMPORTANT**

*The appliance's warranty is not valid until a Meiko Authorized Service Agent performs a Performance and Installation Inspection.*



## 4 OPERATION

### 4.1 Location and Description of Controls

The dishwasher controls are on the control box. See Figure 4-1.

**Figure 4-1: Dishwasher controls**

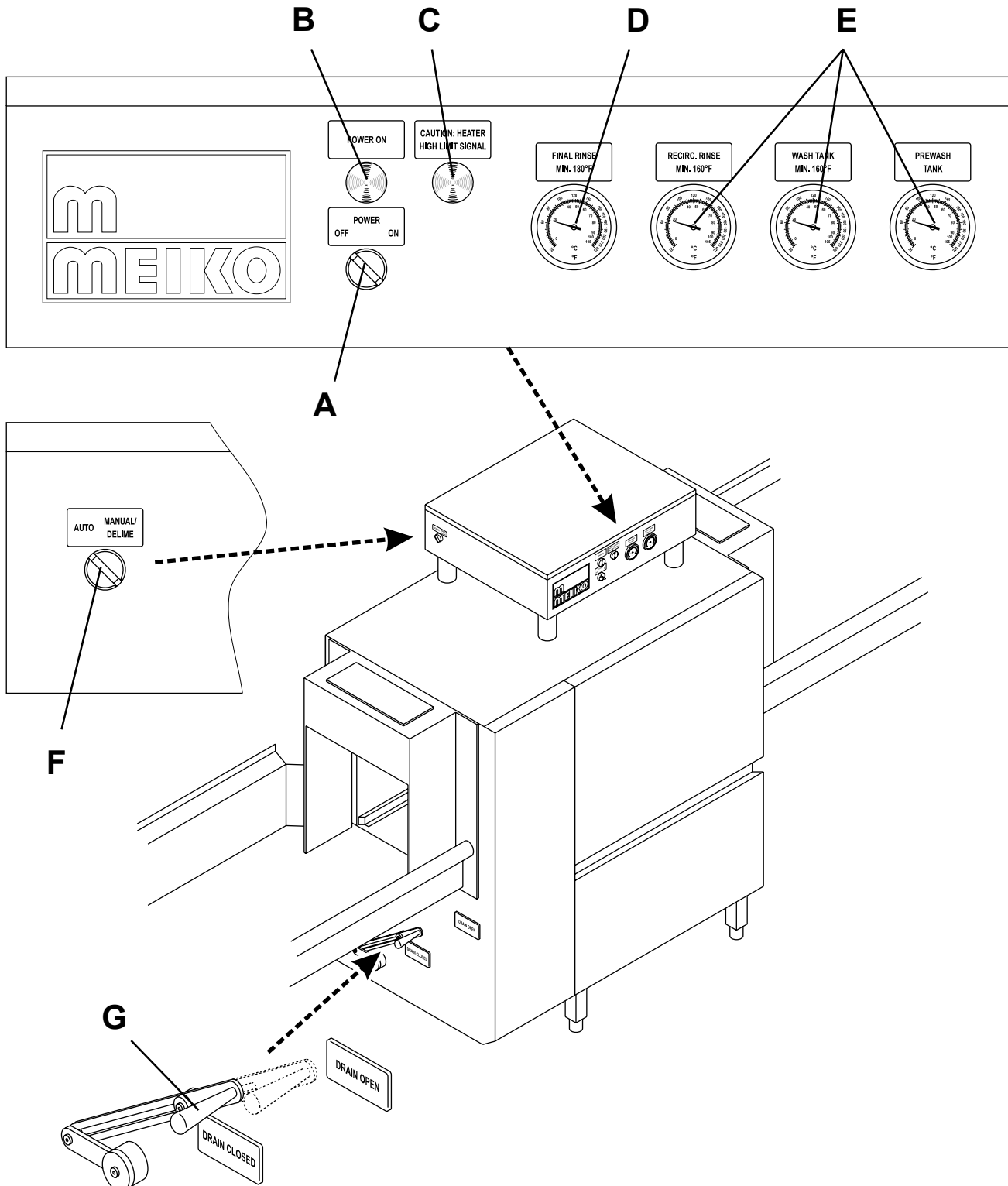

**A - POWER switch**

Switches the machine on and off. When switched on at the beginning of a shift, the machine automatically begins to fill. The automatic rack drive will engage when a rack is loaded.

**B - POWER ON light (red)**

Illuminates when the POWER switch is in the ON position.

**C - HEATER HIGH LIMIT light (amber)**

Only present on machines with electric tank heat. Illuminates when the machine enters high limit safety shutdown. This occurs when the machine detects that the heaters are in excess of their correct temperature. If this light illuminates, contact your Meiko Authorized Service Agent.

**D - FINAL RINSE temperature gauge**

Shows the current temperature of the final rinse. 180°F is the minimum temperature for hot water sanitizing.

**E - Tank temperature gauges**

Shows the temperature inside the wash tank, power rinse tank (if so equipped) and prewash tank (if so equipped). The minimum temperatures for each tank are shown on labels on the control panel.

**F - AUTO/MANUAL switch**

Sets the machine to automatic mode (racks load automatically and engage the wash and rinse when required), or manual mode (wash and rinse are in continuous operation). Manual mode is used for delimiting.

**G - External drain handle(s)**

Opens and closes the drain. The handle is located on the unload end of the machine. For machines equipped with a prewash section (K-66, K-76, K-80, K-86, K-90, K-100), there is a second external drain handle (for the prewash tank) on the load end of the machine.

**4.2 Startup**

Check the level of the external detergent and rinse aid dispensers. If necessary, replace or refill the dispensers.

Check that all components are correctly installed into the machine, including prewash, wash, and recirculating rinse arm manifolds, final rinse arms, curtains, scrap screens and baskets.

Check that the front access door(s) are closed.

Switch the circuit breaker/fused disconnect to the ON position.

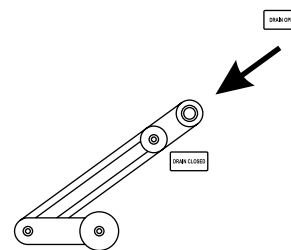

Check that the external drain handle(s) are in the DRAIN CLOSED position.



Check that the AUTO/MANUAL switch is set to the AUTO position.

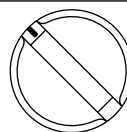

Switch the POWER switch to the ON position to turn on the dishwasher. The POWER ON light will illuminate to show that the machine has been turned on.

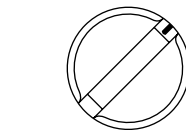
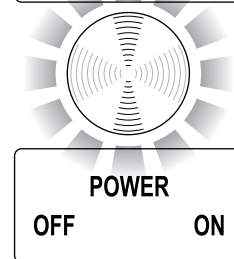

Allow the machine to fill and preheat. This should take approximately 10 minutes. Check the temperature gauges on the front of the machine to ensure that the correct tank temperatures are reached.

### 4.3 Loading

The loading guidelines shown here will lead to faster, more efficient cleaning of your dishware.

Ware such as trays, sheet pans, plates and bowls should be loaded into the racks facing front or rear - so that the edges enter the machine first. If they are loaded facing the sides (so that the large front or rear faces enter the machine first), they may bind on the curtains or shift in the racks as they touch the curtains. Items should not extend past the edges of the rack.

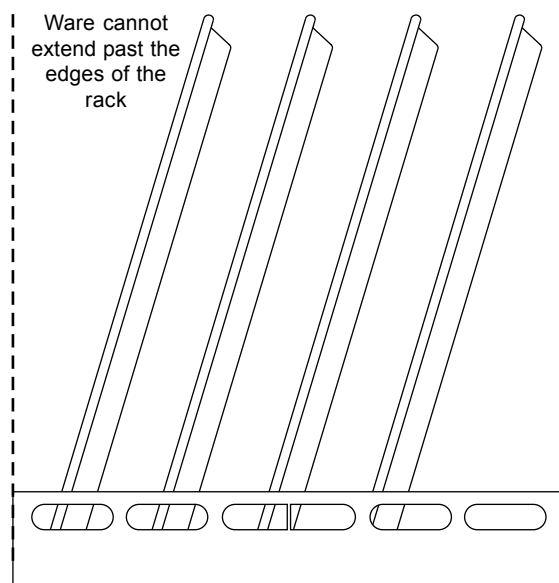
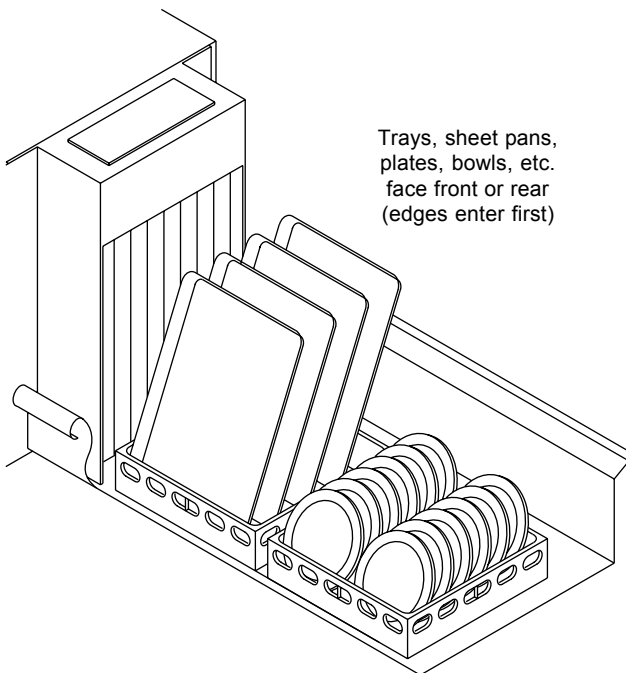

Load plates, soup bowls, etc. at an angle with the inside face pointing up. Ensure that water cannot pool in the bottom of bowls.

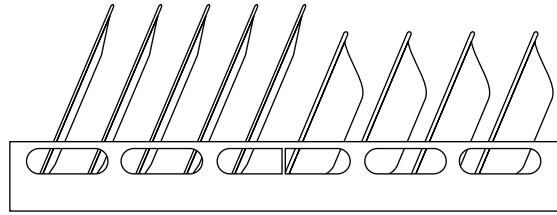

Load hollow or concave dishware (glasses, large bowls, etc.) upside-down and at an angle. This allows water to drain more quickly, preventing stains.

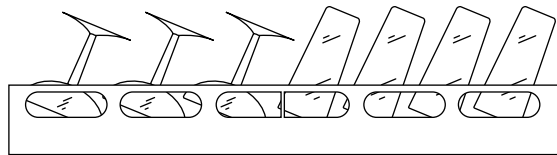

For greater efficiency in loading cutlery, you can use cutlery holders. When loading them:

- Do not overload the cutlery holders.
- Always load knives, forks and spoons with the handle DOWN.
- Do not load identical ware into any given holder. Instead, load an assortment of knives, forks and spoons into each holder. Identical ware is often too closely spaced for effective cleaning.

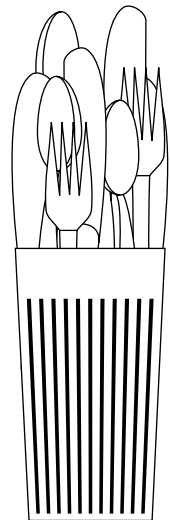

Do not stack items in a rack, such as plates, glasses, etc. Stacked items require multiple cleaning cycles because the wash water cannot reach the food residue. It is more efficient to load each rack with fewer items to ensure effective water coverage on the first wash.



### 4.4 Operation

Operation of the dishwasher is fully automatic. Simply push a rack into the entrance end of the dishwasher until the rack conveyor drive engages.

As the rack is pulled through the machine, it automatically activates water jets at each zone - prewash (if so equipped), wash, recirculating rinse (if so equipped), and final rinse. Curtains between the zones prevent splashing of soiled water into the next zone. After the final rinse, the rack is pushed out of the machine.

If the machine is equipped with an optional table limit switch, the conveyor drive will stop if the switch at the end of the clean dishtable is engaged. When the racks of clean ware are removed, operation can continue normally.

During idle periods, the dishwasher automatically maintains water temperature in the tanks, allowing instant recovery.

### 4.5 Clearing Jams

Under normal operating conditions, racks will not jam as they move through the machine. However, improper loading or improper curtain installation may cause a rack to jam. When clearing a jam, ALWAYS switch the POWER switch to the OFF position before opening the front access doors OR reaching into the machine.



**WARNING!**

*Before clearing a jam, ALWAYS switch the POWER switch to the OFF position.*



**WARNING!**

*When the front access doors are opened, steam will escape the interior of the machine.*

### 4.6 Shutdown

Check that the last rack has exited the machine.

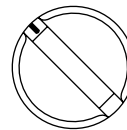
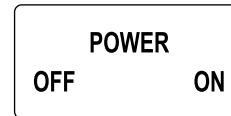
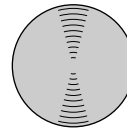

Switch the POWER switch to the OFF position to turn the dishwasher off. The POWER ON light will turn off.

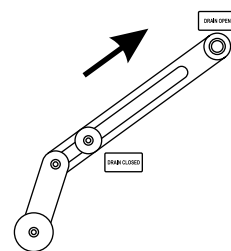

Pull on the external drain handle(s) to empty the tank(s).

Switch the circuit breaker/fused disconnect to the OFF position.

Open the front access door(s). Clean the machine as described in Section 5, "Cleaning." Meiko recommends that the door of the dishwasher be left open overnight to allow it to air thoroughly.



**WARNING!**

*Before opening the doors, check that the POWER switch is in the OFF position.*



**WARNING!**

*When the front access doors are opened, steam will escape the interior of the machine.*



**WARNING!**

*For your safety, allow the interior of the machine to cool before cleaning.*



## 5 CLEANING



### **WARNING!**

Before ANY cleaning, check that the circuit breaker/fused disconnect is in the OFF position and that the unit is switched off.



### **WARNING!**

When the front access doors are opened after operation, steam will escape the interior of the machine.



### **WARNING!**

For your safety, allow the interior of the machine to cool before cleaning.

### **IMPORTANT**

The headings *Daily Cleaning* and *Weekly Cleaning* in this section are general recommendations based on typical soiling.

If soil begins to accumulate, the unit should be cleaned more frequently. Extensive food soil deposits inside the machine work against optimal performance. Some items may not be cleaned as effectively, resulting in the need for either a longer cycle or repeat washing. In addition, heavy soiling in the wash water increases detergent consumption.

### **5.1 Daily Cleaning (or as required)**

Once per day, or as required, perform the following steps:

- Open the front access doors.
- Remove the scrap screens (and prewash scrap basket, if so equipped). Discard any food particles, scraps or bones. Then, clean the screens using a brush and warm water.
- Check the interior of the machine for any food particles or debris. Then, clean the interior. The tanks slope to the front for easier cleaning using a low-pressure hose or spray nozzle.

### **CAUTION**

Never use a high-pressure water spray when cleaning the machine.

- Leave the doors of the machine open. Allow the interior of the machine, as well as all scrap screens and baskets, to air dry thoroughly overnight.
- Reassemble all components into the dishwasher before operation.

### **5.2 Weekly Cleaning (or as required)**

Once per week, or as required, perform the following steps:

- With the scrap screens removed from the machine, remove the wash arm manifolds. See Figure 5-1. If the machine is equipped with a prewash or recirculating rinse section, the arms and manifolds can also be removed at this time.

### **IMPORTANT**

Upper and lower manifolds are NOT interchangeable. However, some machines may have prewash or recirculating rinse manifolds that are identical to the wash arm manifolds. In these machines, the manifolds are interchangeable for easy replacement into the machine.

- Rotate each end cap counterclockwise to remove it from the end of its wash arm. The tether prevents the loss of the cap during cleaning.
- Clean the inside and outside of the manifolds, arms and end caps thoroughly with a brush and warm water.
- Remove the upper and lower rinse arms as shown in Figure 5-1.

### **IMPORTANT**

Upper and lower rinse arms are NOT interchangeable. However, the arms are designed so that they cannot be reinstalled in the wrong location. Note that the lower arm is shorter than the upper arm.

- Clean the inside and outside of the arms thoroughly using a brush and warm water.
- Allow all arms, manifolds and end caps to air dry thoroughly overnight.
- Reassemble all components into the dishwasher before operation.

**Figure 5-1: Arm removal**

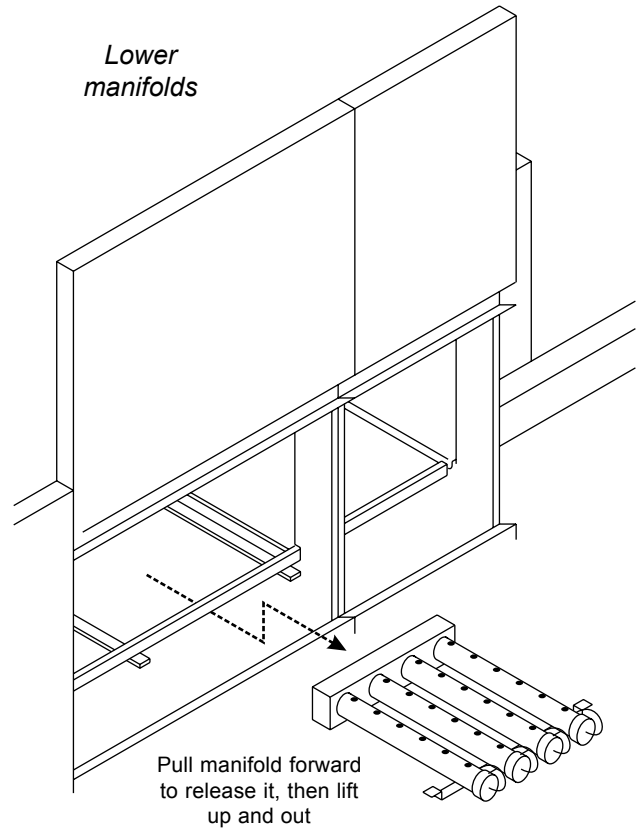
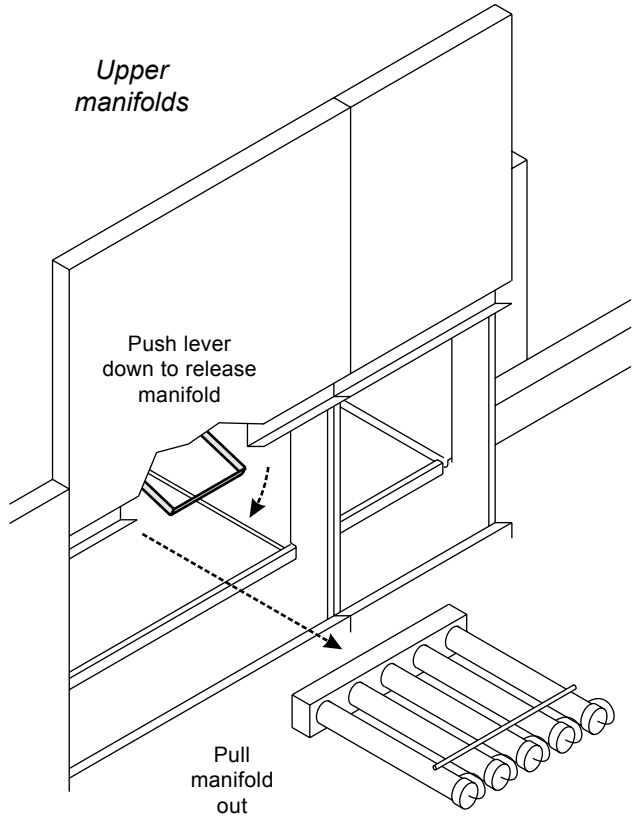

To reinstall, seat the water inlet at the back of the manifold firmly onto the water supply tube. Then, push the front of the manifold up until it snaps into place.

To reinstall, slide the manifold into its track, checking that the front support clips are seated properly on their rails. Then, push the manifold back until it snaps into place.

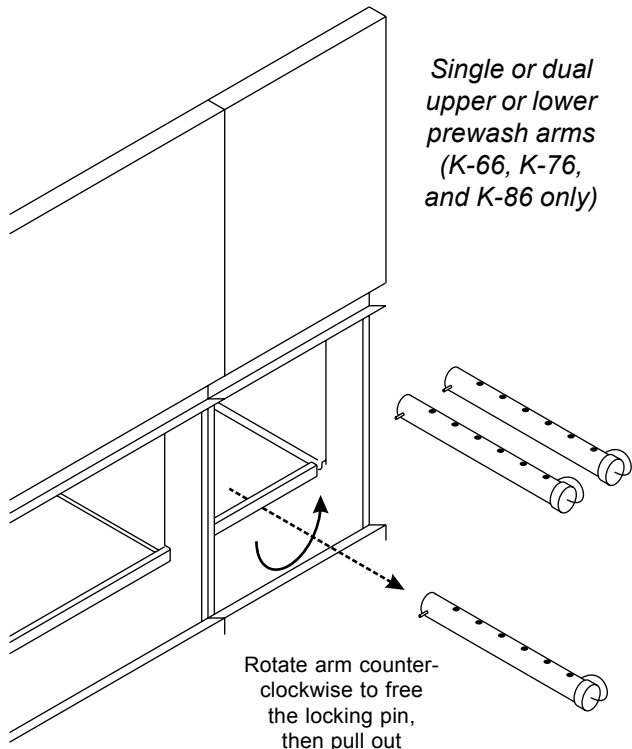

To reinstall, seat the back end of the arm in its socket, then rotate it clockwise to lock it in place.

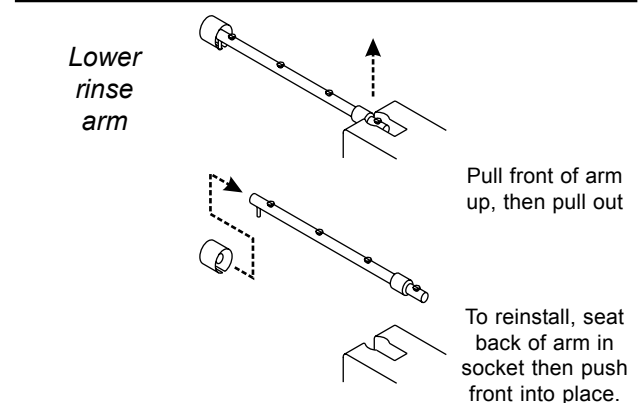
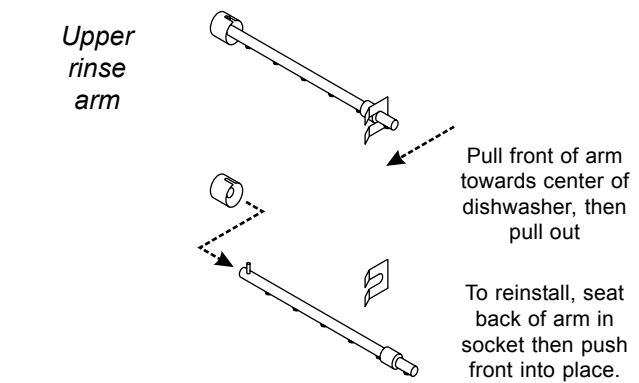

### 5.3 Exterior cleaning (as required)

#### CAUTION

When cleaning the exterior of the dishwasher, be sure to follow these guidelines:

- A commercial stainless steel cleaner can be used on exterior body panels. Follow the manufacturer's directions.
- Meiko strongly recommends using detergent, instead of a stainless steel cleaner, when cleaning the control panel of the unit. These chemicals can damage the gauges, lights and labels.
- Never use abrasive cleaners or pads when cleaning the exterior of the dishwasher. These can scratch the surface of the unit.



#### WARNING!

Ensure that detergents and stainless steel cleaners are kept out of the interior of the dishwasher. If the interior of the unit requires cleaning, refer to the delimiting procedures (Section 5.4).

### 5.4 Delimiting (as required)

Lime scale deposits will occur over time on the interior of the dishwasher if it is operated using a hard water supply. Meiko recommends a hardness of 4 grains per U.S. gallon (7 DH German hardness).

A delimiting or de-scaling process can be used to remove these deposits, as well as any accumulated food residue.

When delimiting the interior, be sure to follow these guidelines:

-  Switch the AUTO/MANUAL switch to the MANUAL position.

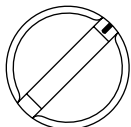

This activates the conveyor and the wash pumps, but does NOT activate the final rinse. Final rinse activation adds fresh water to the machine, which interferes with the delimiting process.

- Use delimiting agents designed for use with commercial dishwashers.
- Follow the instructions for the delimiting agent that is used.
- After the delimiting procedure, continue to run the dishwasher in MANUAL mode for at least 10 minutes to rinse the interior thoroughly.



Switch the AUTO/MANUAL switch to the AUTO position.

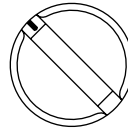

- Switch the POWER switch to the OFF position. Pull the external drain handle(s) to drain the machine.
- Remove all scrap screens, baskets, wash arm manifolds, prewash and recirculating rinse arms (if so equipped), and final rinse arms. Clean them as described in Sections 5.1 and 5.2 of this Manual.
- Inspect the interior for any remaining delimiting agent residue. If residue is present, remove it using a soft cloth and hot water.
- Thoroughly flush the interior of the dishwasher using warm water from a low-pressure hose or spray nozzle.

#### CAUTION

Never use a high-pressure water spray when cleaning the machine.

- Leave the doors of the machine open to allow the interior to air dry thoroughly.
- Reassemble all components into the dishwasher before operation.



#### WARNING!

Ensure that ALL residue of the delimiting agent is removed. Residue from the agent can:

- Pose a health hazard;
- Damage seals and plastic components inside the dishwasher.

## 6 TROUBLESHOOTING

If the dishwasher encounters a problem, check this Troubleshooting Guide. Some simple problems can be quickly resolved, allowing the dishwasher to be returned to operation faster than placing a service call.

<b>Problem</b>	<b>Action</b>
<b>HEATER HIGH LIMIT light is illuminated</b>	<ul style="list-style-type: none"> <li>On machines with electric tank heat, this light will illuminate if the machine enters a high limit safety shutdown. Contact your Meiko Authorized Service Agent.</li> </ul>
<b>Machine does not fill</b>	<ul style="list-style-type: none"> <li>Check that the external drain handle(s) are in the DRAIN CLOSED position.</li> <li>Check that the table limit switch (if so equipped) is not engaged.</li> <li>Check that the water supply is turned on.</li> <li>Check the dirt trap(s) in the water inlet(s) and clean them if necessary.</li> <li>Check the float switches in the tank(s). If the switch(es) are dirty or coated with chemicals or lime deposits, they may not function correctly. If they are dirty, clean or delime the interior.</li> </ul>
<b>Final rinse does not activate</b>	<ul style="list-style-type: none"> <li>Check that the water supply is turned on.</li> <li>Check that the AUTO/MANUAL switch is properly set in the AUTO position.</li> <li>Check the dirt trap in the hot water inlet and clean it if necessary.</li> <li>Check the water pressure at the final rinse pressure gauge. If the water supply is turned on, the dirt trap is clean, and there is still low pressure at the gauge, there may be low water pressure being supplied to the machine.</li> </ul>
<b>Steam escapes the machine during operation</b>	<p>All rack conveyor dishwashers release some steam at the ends of the machine. However, if steam is excessive, check the following:</p> <ul style="list-style-type: none"> <li>Check that the curtains are correctly installed.</li> <li>Check that the baffles in the vent cowl collars (if so equipped) are correctly positioned. The baffles should be opened just enough to prevent steam from escaping the ends of the machine with the curtains installed.</li> </ul>
<b>Water leaks around front access door seams during operation</b>	<ul style="list-style-type: none"> <li>Check that the end caps are correctly installed at the end of all wash arms, as well as prewash and recirculating rinse arms (if so equipped).</li> </ul>
<b>Stripes/smears on ware</b>	<ul style="list-style-type: none"> <li>Check that the curtains are installed properly.</li> <li>Check that the ware is correctly loaded into the racks. Refer to the <b>Operation</b> section of this Manual.</li> <li>Check for correct detergent and rinse aid concentration.</li> <li>Check for excessive mineral content in the water supply. Meiko recommends a hardness of 4 grains per U.S. gallon.</li> </ul>
<b>Foaming in the wash tank</b>	<ul style="list-style-type: none"> <li>Check that commercial (not domestic) detergents and rinse aids are being used.</li> <li>Check for correct detergent and rinse aid concentration.</li> <li>Check that heavily soiled ware is being correctly pre-scraped. Excessive amounts of grease or soiling in the wash tank can cause foaming.</li> <li>Check that the tank temperatures on the control panel gauges are correct.</li> </ul>

**Contact your Meiko Authorized Service Agent if you cannot correct the problem.**

**An Authorized Service Agency Listing was supplied with your dishwasher. If you do not have the listing, call 1-800-868-3840 for assistance, or visit Meiko's website at [www.meiko.us](http://www.meiko.us).**





# *If you need service...*



Meiko warewashers are designed for solid reliability as much as for outstanding ware-cleaning ability. With proper care, your warewasher should provide years of trouble-free operation.

If service is necessary, contact your local Meiko Authorized Service Agent. With factory training, OEM parts and direct support from the factory, Meiko's nationwide service network is highly qualified to quickly restore your warewasher to regular operation.

**An Authorized Service Agency Listing is supplied with this Manual. If you do not have the listing, call 1-800-868-3840 for assistance.**



**Meiko**  
917 Airpark Center Drive  
Nashville, TN 37217  
Phone: (615) 399-6600  
(800) 55-MEIKO  
Fax: (615) 399-6620