

# Continental



## Refrigerator

### DISPLAY FREEZERS

Utilizing Environmentally Safe, CFC-free R-404A Refrigerant



1F-GD



2F-GD



3F-GD

### Standard Features

- Modern, State-of-the-Art Styling
- Performance Rated Refrigeration System Designed for 0°F Cabinet
- Thermal Expansion Valve Governs Refrigerant Flow For Quick Recovery
- 3" Non-CFC Polyurethane Foam Insulation
- Cam-Action Lift-Off Hinges
- Self-Closing Doors
- Magnetic Snap-In Door Gasket
- Cylinder Lock In Each Door
- Automatic Electric Condensate Evaporator
- 5" Casters
- Heavy-Duty, Epoxy-Coated Steel Shelves
- External Dial Thermometer
- Automatic Electric Defrost
- Triple-Pane, Tempered Hinged Glass Doors
- Fluorescent Interior Lighting

Standard (S/S Front, Aluminum Ends & Interior)

Suffix SA (S/S Exterior, Aluminum Interior)

Suffix SS (S/S Exterior & Interior)

### Optional Features & Accessories

- Half Door
- Remote
- Stainless Steel or Black Legs
- Digital Thermometer
- Rehinging of Doors
- Increased Refrigeration Systems
- Pass-Thru
- Shallow Depth
- Pan Slide Assemblies
- Stainless Steel Shelves
- Stainless Steel Case Back





**FREEZERS**

	1F-GD One Section		2F-GD Two Section		3F-GD Three Section	
	Reach-In	Reach-In	Pass-Thru	Pass-Thru	Reach-In	Pass-Thru
(Glass One Side) (Glass One Side)						

**CHARACTERISTICS**

**DIMENSIONAL DATA**

Net Capacity (cu.ft.)	20	48	48	70	70
Width, Overall (in.)	26	52	52	78	78
Depth, Overall (Incl. Hdls.) (in.)	35 <sup>1</sup> / <sub>2</sub>	35 <sup>1</sup> / <sub>2</sub>	39	35 <sup>1</sup> / <sub>2</sub>	39
Depth (Less Door(s)) (in.)	32	32	32	32	32
Depth (Door(s) Open 90°) (in.)	55 <sup>1</sup> / <sub>2</sub>	55 <sup>1</sup> / <sub>2</sub>	79	55 <sup>1</sup> / <sub>2</sub>	79
Clear Door Width (in.)	19 <sup>3</sup> / <sub>8</sub>	19 <sup>3</sup> / <sub>8</sub>	19 <sup>3</sup> / <sub>8</sub>	19 <sup>3</sup> / <sub>8</sub>	19 <sup>3</sup> / <sub>8</sub>
Clear Full-Door Height (in.)	58 <sup>5</sup> / <sub>8</sub>	58 <sup>5</sup> / <sub>8</sub>	58 <sup>5</sup> / <sub>8</sub>	58 <sup>5</sup> / <sub>8</sub>	58 <sup>5</sup> / <sub>8</sub>
Clear Half-Door Height (in.)	27 <sup>1</sup> / <sub>2</sub>	27 <sup>1</sup> / <sub>2</sub>	27 <sup>1</sup> / <sub>2</sub>	27 <sup>1</sup> / <sub>2</sub>	27 <sup>1</sup> / <sub>2</sub>
Height, Overall (Incl. 5" Casters) (in.)	83 <sup>3</sup> / <sub>4</sub>	85 <sup>3</sup> / <sub>4</sub>	85 <sup>3</sup> / <sub>4</sub>	85 <sup>3</sup> / <sub>4</sub>	85 <sup>3</sup> / <sub>4</sub>
No. of Full Door(s)	1	2	4	3	6
No. of Half Door(s)	2	4	8	6	12
No. of Shelves	4	8	8	12	12
Shelf Area (sq. ft.)	20.4	40.8	40.8	61.2	61.2
Tray Slide Capacity (Half)	11 ea.	11 ea.	11 ea.	11 ea.	11 ea.
Tray Slide Capacity (Full)	24 ea.	24 ea.	24 ea.	24 ea.	24 ea.

**REFRIGERATION DATA**

Condensing Unit Size (H.P.)	1/2	1	1	1 1/2	1 1/2
Capacity (BTU/Hr)**	2470	4325	4325	6050	6050

**ELECTRICAL DATA**

Cabinet Specifications	115/60/1	115/208-230/60/1	115/208-230/60/1	115/208-230/60/1	115/208-230/60/1
Feed Wires (Incl. Ground)	3	4	4	4	4
Condensing Unit Specs.	115/60/1	208-230/60/1	208-230/60/1	208-230/60/1	208-230/60/1
Total Amperes	11.4	14.0	14.7	22.5	23.5
Cabinet Amperes	3.5	4.8	5.5	6.1	7.1
Defrost Amperes	5.2	9.6	9.6	10.4	10.4
Power Supply Cord	yes	no	no	no	no

**SHIPPING DATA**

Height – crated (in.)	85 <sup>1</sup> / <sub>2</sub>	85 <sup>1</sup> / <sub>2</sub>	85 <sup>1</sup> / <sub>2</sub>	85 <sup>1</sup> / <sub>2</sub>	85 <sup>1</sup> / <sub>2</sub>
Width – crated (in.)	31 <sup>5</sup> / <sub>8</sub>	64	64	90	90
Depth – crated (in.)	42	42	42	42	42
Volume – crated (cu. ft.)	65	133	133	187	187
Weight Std – crated (lbs.)	330	565	705	805	930
Weight SS – crated (lbs.)	390	645	785	920	1045
Weight Std – uncrated (lbs.)	230	395	515	595	705
Weight SS – uncrated (lbs.)	290	475	595	710	820

\*Rating @ -15°F Evaporator, 90° Ambient

Note: All specifications subject to change without notice.

Note: If the cabinet is located directly against wall and/or under low ceiling, a minimum clearance of 2" is required.

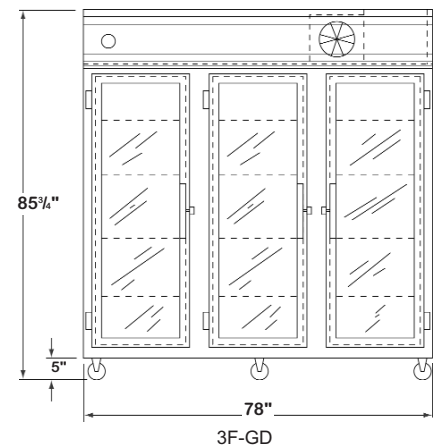
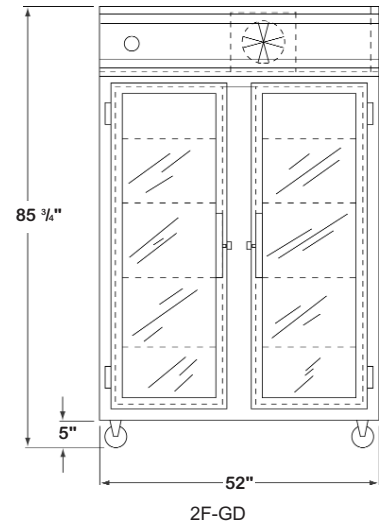
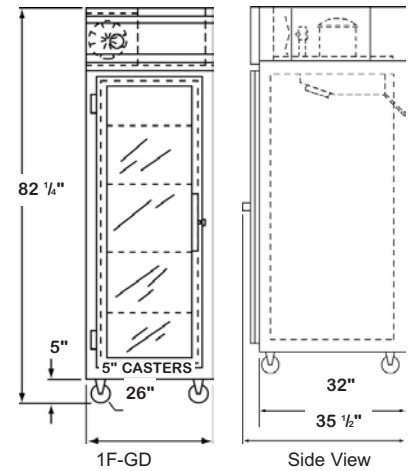

**Continental**  
Refrigerator

A Division of National Refrigeration & A/C Products, Inc.  
539 Dunksferry Road Bensalem, PA 19020  
(800) 523-7138 Fax: (215) 244-9579  
www.continentalrefrigerator.com