

Ultra Camtainers®

For Hot and Cold Beverages

Models UC250 2³/₄ gallon (10,4 L)
 UC500 5¹/₄ gallon (19,9 L)
 UC1000 10¹/₂ gallon (39,7 L)



Features & Benefits

- Attractive sleek look is perfect for front-of-the-house hot and cold beverage service. Stacks easily for storage and transportation and will also stack with Camtainer® Insulated Containers.
- Serving capacity:
 - Model UC250 - 50 each 7 oz. (210 mL) cups
 - Model UC500 - 96 each 7 oz. (210 mL) cups
 - Model UC1000 - 192 each 7 oz. (210 mL) cups
- Single-molded, seamless, double-wall, high-density, polyethylene construction is highly durable, dishwasher safe, and resists dings and dents. Textured exterior is scratch-resistant.
- Polyurethane foam insulation provides excellent hot or cold temperature retention for hours. Hot beverages remain hot without the need for a costly external heating source.
- E-Z grip molded-in handles offer comfortable, easy transporting.
- Nylon over-center latch design ensures easy opening and closing and helps to maintain maximum temperature retention.
- Drip proof recessed large spigot allows for convenient access and accommodates large drinking vessels. Optional Easy-Serve Dispenser lever makes dispensing a snap.
- Vent cap helps to equalize pressure and release steam.
- Self-adhesive beverage labels included for quick identification of contents.
- Optional Condiment Holders and Risers fit all models.
- Optional Camdollies™ offer easy transporting.
- Non-electrical.
- No assembly required.
- Available in 15 colors.

Item No. _____

Specifier Identification No. _____

Model No. _____

Quantity _____



UC1000

UC500

UC250



Dispensing becomes as easy as pressing a cup against the optional Easy Serve Dispenser under spout.



Large opening accommodates wide drinking vessels. Recessed faucet is positioned to handle larger cups.

"Ultra Camtainers Keep Beverages Hot for Hours!"

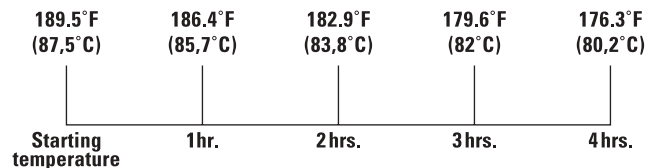

"Ultra Camtainers Keep Beverages Cold for Hours!"

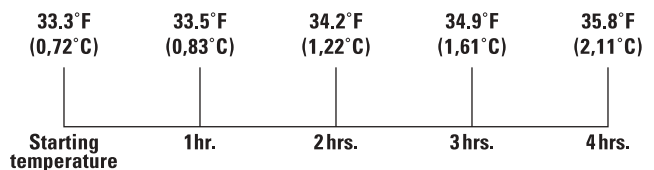

Approvals



Ultra Camtainers®

For Hot and Cold Beverages

Models UC250 2³/₄ gallon (10,4 L)

UC500 5¹/₄ gallon (19,9 L)

UC1000 10¹/₂ gallon (39,7 L)

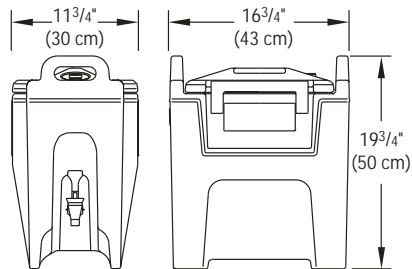

UC250

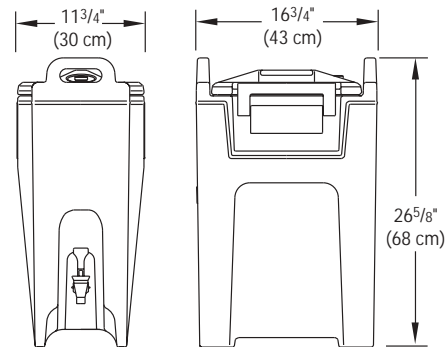

UC500

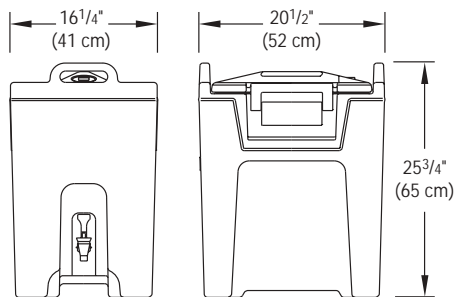

UC1000

Item No. _____

Specifier Identification No. _____

Model No. _____

Quantity _____

Specifications

Dimension Tolerance: +/- 1/4" (0,64 cm)

Code	Description	Total Capacity	Serving Capacity 7 oz. (210 mL) cups	Dimensions W x D x H	Case lbs./cube Kg./m ³
UC250	Ultra Camtainer	2 ³ / ₄ gal. (10,4 L)	50	11 ³ / ₄ " x 16 ³ / ₄ " x 19 ³ / ₄ " (30 x 43 x 50 cm)	17 (2.48) 7,7 (0,069)
UC500	Ultra Camtainer	5 ¹ / ₄ gal. (19,9 L)	96	11 ³ / ₄ " x 16 ³ / ₄ " x 26 ⁵ / ₈ " (30 x 43 x 68 cm)	21 (3.25) 9,5 (0,09)
UC1000	Ultra Camtainer	10 ¹ / ₂ gal. (39,7 L)	192	16 ¹ / ₄ " x 20 ¹ / ₂ " x 25 ³ / ₄ " (41 x 52 x 65 cm)	31 (4.21) 14,1 (0,118)

Optional Accessories

- Riser**
- R500LCD fits UC250 & UC500
 - R1000LCD fits UC1000
- Condiment Holder**
- LCDCH fits UC250 & UC500
 - LCDCH10 fits UC1000
- Easy Serve Dispenser**
- LCDES Black (110)
- Camdolly™**
- CD100 CD100H fits UC250 and UC500
 - CD100HB fits UC250 and UC500
 - CD300 CD300H fits UC1000
 - CD300HB fits UC1000

Standard Colors

- Dusty Rose (400)
- Navy Blue (186)
- Slate Blue (401)
- Cold Blue (159)
- Coffee Beige (157)
- Dark Brown (131)
- Brick Red (402)
- Green (519)
- Black (110)
- Hot Red (158)
- Dark Taupe (417)
- Granite Gray (191)
- Granite Green (192)
- Granite Red (193)
- Granite Sand (194)

Architect Specs

The portable non-electrical hot and cold beverage container/server shall be an Ultra Camtainer, Models ..., manufactured by Cambro Mfg. Co., Huntington Beach, CA 92648 U.S.A. It shall be made of one-piece, seamless, double-wall, high-density polyethylene and foam-injected polyurethane. It shall have a vent cap to help equalize pressure and release steam. It shall have durable, nylon over-center latches. It shall have E-Z grip molded-in handles. It shall have a drip proof, recessed serving spigot designed with easy finger adjustment. It shall have the option of an Easy Serve Dispenser lever. It shall have self-adhesive beverage labels to use for quick product identification. It shall have an optional Condiment Holder and Riser. It shall require no assembly and shall be available in 15 colors.

Approvals

