

# Continental

---

---

## Refrigerator

Operation, Installation and  
Instruction Manual  
For

### **Forced Air & Cold Wall Milk Coolers**

A Division of National Refrigeration & Air Conditioning Products, Inc.  
539 Dunksferry Road " Bensalem, PA 19020-5908  
215-244-1400 • 1-800-523-7138 • Fax: 215-244-9579  
[www.continentalrefrigerator.com](http://www.continentalrefrigerator.com)

REV10/04

# Operators Manual

<b>Table of Contents</b>	<b>Page</b>
Receiving Your New Model .....	3
General Information And Important Operating Facts .....	3
Uncrating Your New Model .....	4
Installation And Location2Clearances .....	4
Ventilation .....	4
Floor Loads .....	5
Locating Condensate Evaporator - Forced Air Model.....	6
Cabinet Washout Drainage Hose .....	7
Initial Cleaning Procedure .....	7
Start-Up Procedure .....	8
Electrical Connections.....	8
115 Volt, 60 Hz, 1 Phase Connection .....	8
208-230 Volt, 60 Hz, 1 Phase Connection .....	8
Special Voltage Connections .....	9
Start-Up Checklist .....	9
Remote Applications .....	9
Operation .....	10
Thermometer Calibration .....	10
Calibration Check.....	10
Dial Thermometer .....	10
Optional Digital Thermometer .....	11
“Cold Wall” Refrigeration System And Adjustment .....	12
“Forced Air” Refrigeration System And Adjustment .....	13
Interior Accessories .....	14
Safety Precautions .....	15
Maintenance.....	15
Periodic Cleaning Procedure .....	15
Precautions .....	15
General Preventative Maintenance .....	15
Parts And Service.....	15
Troubleshooting And Servicing Guide .....	17
Wiring Diagrams.....	22
Warranty .....	23

## **RECEIVING YOUR NEW MODEL**

Congratulations on your recent purchase of continental refrigerator superior food equipment products! When your shipment arrives, please thoroughly examine the shipping crate for any punctures, dents, or signs of rough handling. It is in your best interest to partially remove or open the shipping container in order to examine the model for any concealed damages, which may have occurred during shipment. If the model is damaged, it must be noted on the delivering carrier's delivery slip or bill of lading (see "filing a damage claim" under warranty section).

## **GENERAL INFORMATION AND IMPORTANT OPERATING FACTS**

This manual has been compiled to aid in the installation, operation and maintenance of your new equipment. Please take the time to read all of the material in order to become more familiar with your equipment and its operation, and enjoy optimum performance.

All *forced air* and *cold wall* models contain a 1" diameter clean out, floor drain with drain stopper and 3 feet of ¾" ID drain hose. The floor drain is located on the bottom right hand inside floor and the drain hose is located behind the front grill. All forced air models are completely self-defrosting and use an automatic, defrost condensate water evaporating system where the drain pan has been factory installed behind the rear grill. This pan is simply screwed in place and should not have to be removed unless clean out is necessary.

All cabinets must be given sufficient time to reach normal operating temperature before placing any pre-chilled milk inside cabinet. Approximately 1 hour of operation is required to lower the cabinet temperature to 38°F. During pull-down, doors and lids should be kept closed (see "operation" section for further information).

On all forced air and cold wall models, it is strongly recommended that top lids and doors be kept in the closed position when the unit is not in use or between rush periods. This is extremely important during the summer months and in hot kitchens. **Do not** keep the top lids and doors open for prolonged periods of time and **never** operate forced air models for longer than four hours with lids and doors open as evaporator coil can ice and may have to be manually defrosted.

Prior to factory shipping, all models are performance run tested for a minimum of 12 hours providing a highly sophisticated temperature analysis recording exclusive to each individual cabinet. This recording is supplied within this manual packet. A final leak check, vibration, noise level and visual examination is made by a qualified quality control team to assure a quality product. The carrier signs to this effect when he accepts the product for shipping. To insure the maximum in safety and sanitation, all models are listed under the reexamination service of underwriter's laboratories and with the national sanitation foundation.

## **UNCRATING YOUR NEW MODEL**

The shipping container should remain on your model as protection against dents or scratches while transporting it to the actual set-up location. Remove the shipping container only at the last possible moment by following these simple steps:

1. Using a pry bar, pry off and remove crate end bottom staples.
2. Pry off and remove crate front and rear bottom staples.
3. Slide crate upward and remove it, being careful not to rub against cabinet.

There are two (2) bolts securing the cabinet to the wooden skid. The bolts are located at each end on the underside of the skid. Using a  $\frac{3}{4}$ " socket or open-end wrench, remove the bolts and carefully slide the model off of the skid. After skid removal, the cabinet can be rolled onto the floor and into place.

***Important Note:*** Do not under any circumstances lay your new model on its front or sides. Only for a brief period, may you lay the model on its back and only then, when its properly blocked so as not to crush the louvered venting panel and also to allow provision for your hands in order to set it in its upright position without inflicting damage to the cabinet. **Do not plug in and operate model for at least three (3) hours after cabinet is set upright from being on its back as damage could result to the compressor.**

## **INSTALLATION AND LOCATION**

### **CLEARANCES**

Before moving the cabinet to its final point of installation, accurately measure all doorways or passages to assure clearance. If additional clearance is needed, cabinet doors and lids can be easily removed (see instructions outlined in "removal of doors" section).

### **VENTILATION**

The final location site of your forced air or cold wall refrigerator must be able to provide a large quantity of cool, clean air. The refrigeration system operates most efficiently and trouble-free with cool, dry air circulation. Avoid locations near heat and moisture generating equipment such as stoves, ovens, cooking ranges, fryers, dish washers, steam kettles, etc., and also direct sunlight where temperatures can be in excess of 100°F. Also, do not select a location in an unheated room or area where temperatures may drop below 55°F. Air supply to the condensing unit is equally important. Restricting the air supply will place an excessive heat load on the condensing unit and adversely affect its operating efficiency.

**Important Note:** To assure maximum operating efficiency, your new “MC” series model should be located where an unrestricted air supply can be circulated to the condensing unit. For optimum performance, a minimum clearance of 3" on each side and rear of the cabinet **must** be provided. Your model has been designed to operate with only the casters supplied. If necessary, special venting or air supply ducts must be installed by the installer if any of the above conditions cannot be achieved. Do not at any time obstruct the area below the grill in the front or rear of the cabinet in any way, and never place or store anything inside of the cabinet machine compartment. These rules are essential for maximum cooling capacity and long life of refrigeration parts.

## FLOOR LOADS

The floor at the final location site must be level, free of vibration and strong enough to support the total combined weights of your new model plus the maximum product load, which might be placed into it. A fully loaded reach-in model may reach 2,000 - 3,000 pounds. To estimate the possible product load weight, assume that each cubic foot of storage space weighs approximately 35 pounds. Multiply 35 pounds by the amount of cubic feet in the cabinet and obtain the product load weight. For example, a 20 cubic foot refrigerator can hold approximately 700 pounds of product (35 x 20) and assuming the refrigerator itself weighs 300 pounds, the total combined weight of cabinet and product is approximately 1000 pounds. Therefore, the floor in this example must be capable of supporting up to 1000 pounds.

**Important Note:** It is extremely important that your new model is perfectly level for proper operation. If it is not level, the following adverse conditions will become apparent:

1. The door(s) will not be properly aligned and consequently will not provide a good seal.
2. Your model will run excessively due to improper door seal(s).
3. An excessive amount of ice will accumulate inside the cabinet, around the door opening(s) and especially on the finned evaporator coil. If allowed to continue, ice will eventually block the coil and the model will fail. This will result in the loss of all food stored within the cabinet.
4. Defrost water will fail to drain properly and will overflow the evaporator coil drain pan and into the cabinet of both refrigerator and freezer models.

## LOCATING CONDENSATE EVAPORATOR - FORCED AIR MODEL

All Forced air milk cooler models utilize a unique hot air condensate water evaporating system, which is completely self-contained and no further assembly or maintenance is required. To locate and remove (if desired for cleaning) the condensate pan, remove the **rear** cabinet grill cover screws and remove the screws for the mounting bracket holding the pan on top of the compressor (see figure 1). Slide the condensate pan toward you with bracket attached, carefully sliding drain tube from the pan. When re-installing the drain tube into the pan, make sure it is not blocked or kinked. In some adverse conditions such as high ambient temperature, high humidity, extremely heavy usage, and frequent loading for prolonged periods of time, an optional electric condensate evaporator pan may be purchased as an accessory. An electric condensate evaporator pan is also supplied with all remote models. To install an electric condensate pan, remove the rear grill and attach the mounting bracket supplied with the pan to the side of the cabinet being sure not to restrict the airflow of the condensing unit. Slide the condensate pan onto the bracket, re-install the drain tube into the pan and plug the ten-foot power cord into the receptacle labeled “**vaporizer**” located on the compressor compartment electrical box.

***Important Note:*** It is extremely important to be sure that the optional electric condensate pan is plugged into its correct receptacle labeled “vaporizer” and that the condensing unit is plugged into its correct receptacle labeled "condensing unit".

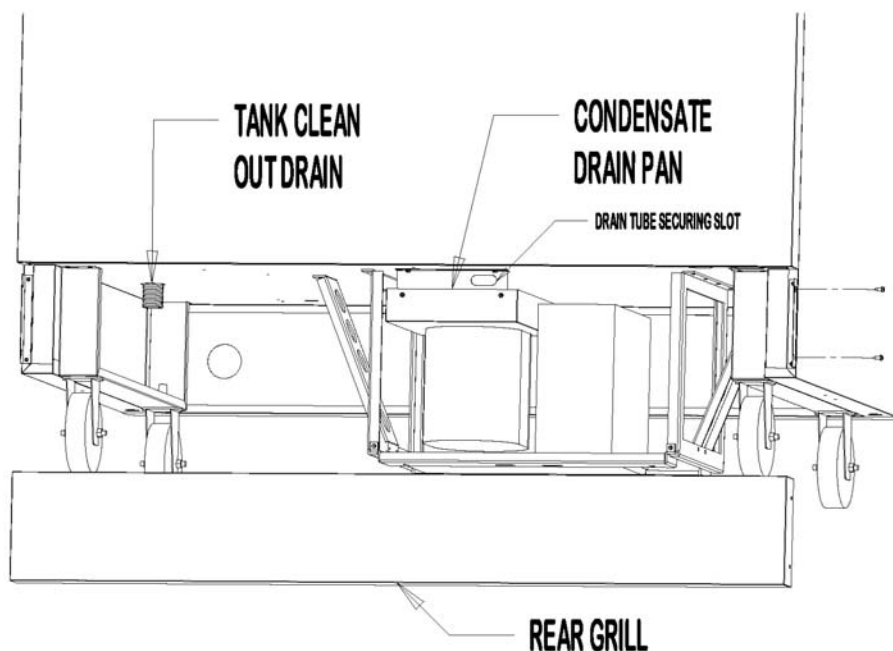

**FIGURE 1**  
**CONDENSATE EVAPORATOR LOCATION - "FORCED AIR" ONLY**

### **CABINET WASHOUT DRAINAGE HOSE**

All forced air and cold wall models contain a 1" diameter clean out, floor drain with drain stopper and 3 feet of ¾" ID drain hose. The floor drain is located on the bottom right hand inside floor and the drain hose is accessible behind either the front or rear grill (see figure 1 for location).

### **INITIAL CLEANING PROCEDURE**

Prior to start-up and before placing any product inside of your new model, the interior of the cabinet should be thoroughly cleaned. Washing with a mild soap and warm water solution is recommended for cleaning the galvanized and stainless steel surfaces of your cabinet. This should be followed by cleaning with a baking soda solution (three (3) tablespoons of baking soda to each quart of warm water). Rinse thoroughly with clear water and dry with a clean, soft cloth.

*Important Note:* Never use harsh detergents, cleaners, scouring powders or chemicals when cleaning your model. Failure to dry the interior surfaces after cleaning may result in a streaking or staining of the metal. Complete cleaning procedures and precautions are listed in the "periodic cleaning procedure" under the maintenance section.

## **START-UP PROCEDURE**

### **ELECTRICAL CONNECTIONS**

To insure proper operation, your new model must be connected to an individual circuit that can supply the full voltage as stated on the cabinet serial data plate. For correct voltage, power draws, and wire accommodations, check the data on the serial data plate located on the inner right wall of your new model. Verify that this information exactly matches the electrical characteristics at the installation location. An electrical wiring diagram, located on the inside compressor compartment rear, next to the electrical console box, should also be consulted during connection. For reference, a copy of each electrical wiring diagram is located at the rear of this manual in the "maintenance" section.

***Important Note:*** The condensing unit supplied with all self-contained models is designed to operate with a voltage fluctuation of + 10 % of the voltage indicated on the cabinet serial data plate. Full voltage of the correct service, on an individual line not affected by the operation of other electrical appliances, must be available to the condensing unit at all times. **Burnout of the compressor due to exceeding the high or low voltage limits is easily detected and will automatically void the factory warranty.**

### **115 VOLT, 60 HZ, 1 PHASE CONNECTION**

All 115 volt models are provided with a U.L. approved power cord and polarized plug which is factory installed.

***Warning:*** Any alterations to this cord and plug could cause an electrical hazard and will void the factory warranty.

To insure proper operation, this equipment must be plugged into a NEMA 5-15r compatible, grounded receptacle that can supply the full voltage as stated on the serial data plate.

### **208-230 VOLT, 60 HZ, 1 PHASE CONNECTION**

All 208-230 volt models are to be permanently connected and are provided with four (4) field wiring leads which exit the electrical console box located in the machine compartment rear, next to the compressor. The cabinet circuitry is 115 volts and the condensing unit is 208-230 volts in which the wiring includes a neutral and a mechanical ground. This wiring should be connected to the appropriate power source by a qualified electrician and must conform to all local electrical codes.

## **SPECIAL VOLTAGE CONNECTIONS**

When models are ordered from the factory with special, optional voltages, connections should be made as required on the electrical wiring diagram provided on the inside compressor compartment rear next to the electrical console box.

## **START-UP CHECKLIST**

After your model has been installed, leveled, cleaned, and electrically connected in accordance with this manual, please take the time before start-up to observe the following precautions to assure trouble free operation:

1. Check that all exposed refrigeration lines are free of severe dents or kinks.
2. Check the condenser fan and evaporator fans for freedom to rotate without any obstructions
3. Make sure that the cabinet is properly leveled (see "leveling" under installation and location section).

The system should run smoothly and quietly in accordance with generally accepted commercial standards. If any unusual noises are heard, turn the unit off immediately and check for any obstructions of the condenser or evaporator fans. Fan motors, fan blades, or fan housings can be jarred out of position through rough handling in transit or during installation.

**Caution:** If unit is unplugged or disconnected for any reason, allow several minutes (5-6 minutes) before turning the unit back on to allow the system pressures to equalize. Disregarding this procedure could cause an overload and prevent the unit from operating.

## **REMOTE APPLICATIONS**

All models are available for purchase as remote models in which case the condensing unit is purchased separately and installed at the time of installation. All remote models are equipped with an expansion valve located within the evaporator coil housing, and both liquid and suction lines stubbed and extending out from the cabinet bottom behind the rear grill. Installation of the refrigeration accessories, condensing unit, and electrical hook-up should be performed by qualified refrigeration personnel of a competent refrigeration company only.

## **OPERATION**

All cabinets must be given sufficient time to reach normal operating temperature before placing any pre-chilled product inside cabinet. Milk cooler refrigerators are designed to maintain an ideal cabinet temperature of 38°F to 40°F (3.3°C to 4.4°C) and approximately 1 hour of operation is required to reach this temperature. During pull-down, doors and lids should be kept closed.

On all forced air and cold wall models, it is strongly recommended that top lids and doors be kept in the closed position when the unit is not in use or between rush periods. This is extremely important during the summer months and in hot kitchens. **Do not** keep the top lids and doors open for prolonged periods of time and **never** operate forced air models for longer than four hours with lids and doors open as evaporator coil can ice and may have to be manually defrosted.

## **THERMOMETER CALIBRATION**

After your new model has been given sufficient time to pull down to the above specified temperature range, the exterior thermometer located on the upper grill **must** be checked for calibration accuracy. All thermometers are carefully calibrated at the factory prior to shipping but may be vibrated out of calibration through rough handling in transit, shipping vibration, or during installation.

## **CALIBRATION CHECK**

To check calibration, an accurate, mercury thermometer (within the temperature range of your model) must be placed inside of the cabinet on the center shelf for at least 15 minutes without any door openings. At this time, note the temperature on the exterior cabinet thermometer, quickly open the door and compare it to the interior thermometers temperature. Whatever the difference (if any) is the amount the exterior thermometer must be adjusted.

The adjustment procedure varies depending on which thermometer is equipped with your model (see figure 2).

## **DIAL THERMOMETER**

For a dial thermometer, carefully pry the clear plastic lens cover from the thermometer body using a slotted screwdriver. To adjust the needle, hold the center hub stationary using a small slotted screwdriver and very carefully grasp and turn the needle to the desired temperature using your fingers. Replace the lens cover and recheck the calibration.

## OPTIONAL DIGITAL THERMOMETER

For a digital thermometer, note how many degrees the digital display needs to be increased or decreased. Press twice directly on the Mylar display towards the right center using your finger. After pressing the first time, the display should read "cal" indicating that you are in the calibration mode and after pressing the second time, the display should read either zero or a positive number or a negative number (this number is the point of origin for calibration). If your digital display needed to be increased, you must advance the point of origin by that many degrees by pressing directly on the Mylar display towards the left top. If your digital display needed to be decreased you must decrease the point of origin by that many degrees by pressing directly on the Mylar display towards the left bottom. Once calibration is complete return to normal temperature mode by pressing once again on the Mylar display towards the right center. Now, recheck the calibration.

Example: the digital display reads 45°F and the internal thermometer reads 40°F so, the digital display must be increased by 5°. Press the right center of the display twice and the number -1 is displayed (this is the point of origin and could have been any number). Now, press the top left of the display five times to make the -1 go to +4. Calibration is complete so press the right center of the display to return to normal temperature mode.

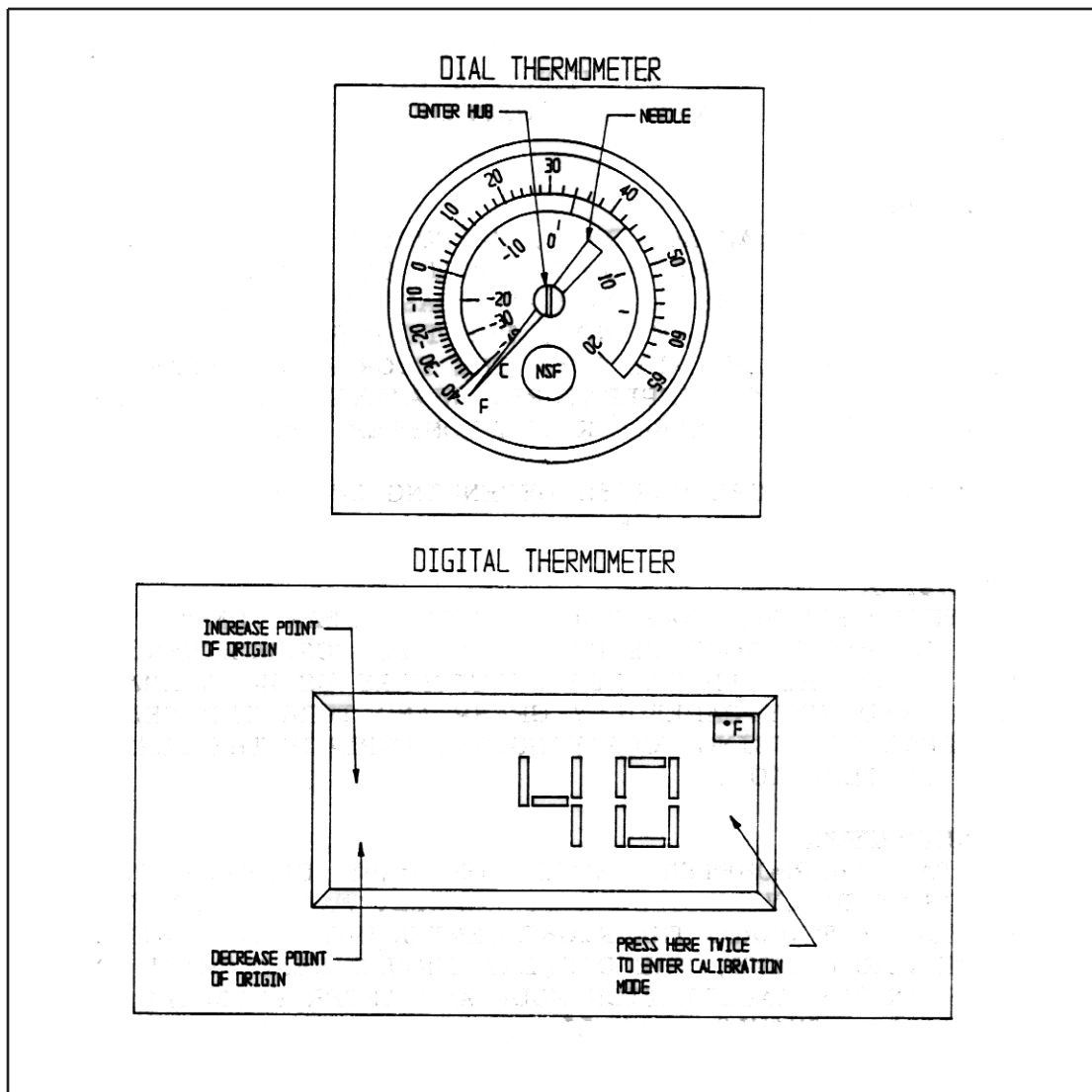

**FIGURE 2**  
**THERMOMETER CALIBRATION**

### **"COLD WALL" REFRIGERATION SYSTEM AND ADJUSTMENT**

All self-contained "cold wall" Milk Cooler refrigerators are designed and factory set to maintain an average cabinet temperature of 36°F. The temperature control is located behind the front grill (grill with thermometer) and accessible by removing the front grill as shown in figure 3. If an adjustment is necessary to maintain the above temperature range only, place a screwdriver into the bottom thermostat adjustment screw labeled "High Event" and turn clockwise for a colder cabinet

temperature or counterclockwise for a warmer cabinet temperature. Note that adjusting a cabinet too cold (below the "High Event" setting of 30°F) could result in freezing your product over long periods of time. Further adjustments out of the factory design temperature range must be made by a qualified refrigeration mechanic only. The cold wall system operates by wall temperatures reaching below freezing (approximate wall temperature is 20°F) and should periodically be manually defrosted to minimize wall ice accumulation. Manual defrost is achieved by disconnecting the power supply to the refrigerator (unplugging power cord or shutting off circuit breaker) for approximately 30 minutes allowing the frost to melt and drain to the floor drain. Care should be taken not to scrape and potentially puncture the wall since the refrigeration tubing is located behind the wall and could be damaged.

**Important Note:** During manual defrost, be sure to have your floor drain connected to a drainage destination.

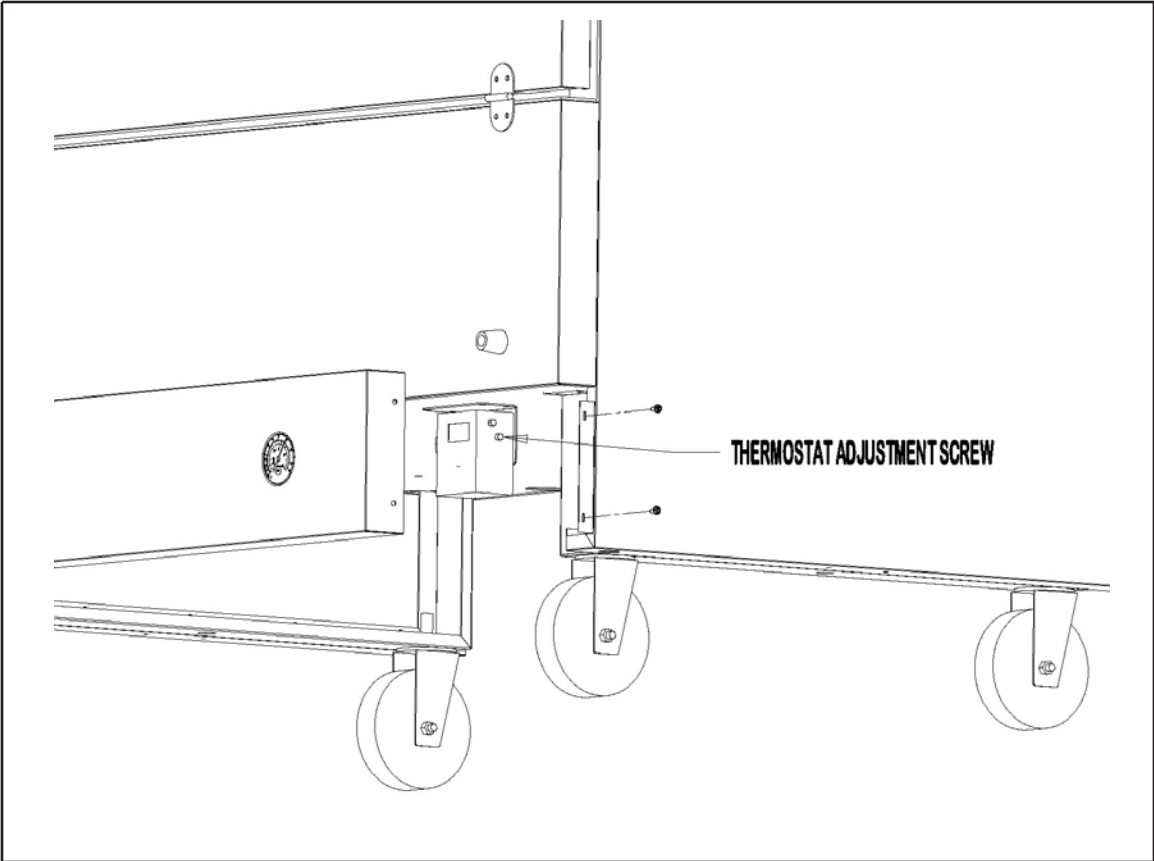

**FIGURE 3**  
**COLD WALL THERMOSTAT**

**"FORCED AIR" REFRIGERATION SYSTEM AND ADJUSTMENT**

All self-contained "Forced Air" Milk cooler refrigerators are designed and factory set to maintain an average cabinet temperature of 36°F. The temperature control is located inside the cabinet product compartment, on the interior top left air distribution grill as shown in figure 4. If an adjustment is necessary to maintain the above temperature range only, place a screwdriver into the thermostat slot and

turn clockwise for a colder cabinet temperature or counterclockwise for a warmer cabinet temperature. Please note that turning the control completely counterclockwise will turn "off" the refrigeration compressor, as it is an "off" position. Further adjustments out of the factory design temperature range must be made by a qualified refrigeration mechanic only.

**Important Note:** All refrigerators are designed with an automatic, "off-cycle" defrost system, which means that defrosting occurs automatically when the compressor is not operating during an off-cycle. Do not set the thermostat too cold where the cabinet temperature will fall below 34°F because the evaporator will become blocked by ice since the compressor off-cycle will be considerably shortened. This will result in loss of product stored within the cabinet and require service to defrost the evaporator and re-adjust the thermostat.

**Caution:** On all "Forced Air" and "Cold Wall" models, it is strongly recommended that top lids and doors be kept in the closed position when the unit is not in use or between rush periods. This is extremely important during the summer months and in hot kitchens. **Do not keep the top lids and doors open for prolonged periods of time and never operate forced air models for longer than four hours with lids and doors open as evaporator coil can ice and may have to be manually defrosted.**

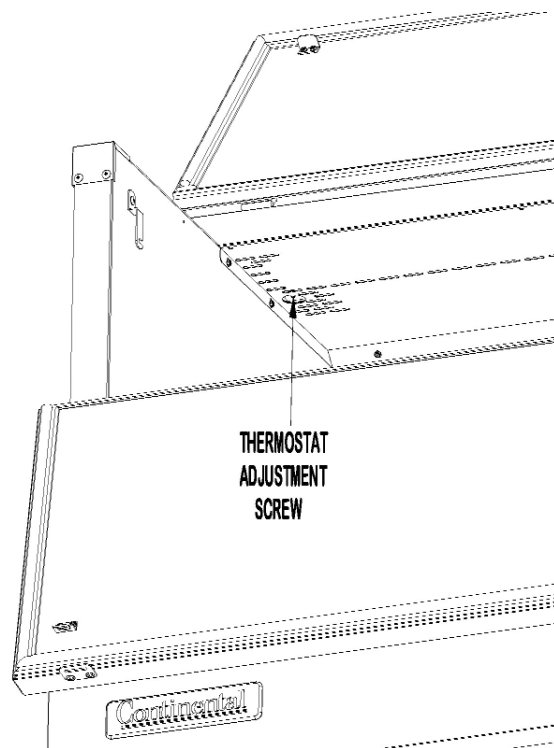

**FIGURE 4**  
**FORCED AIR THERMOSTAT**

## **INTERIOR ACCESSORIES**

The standard interior accessory package that is supplied from the factory with your new Milk Cooler model consists of an epoxy coated, steel wire floor rack which sits on the interior stainless steel floor (MC5 models receive two), and a floor drain stopper.

## **SAFETY PRECAUTIONS**

The following safety precautions should be followed when operating any appliances:

- ★ Always disconnect the power cord before attempting to work on or clean any equipment.
- ★ Disconnect the power cord when the appliance will be idled for a long period of time.
- ★ Do not attempt to service this unit yourself as removing any covers may cause exposure to dangerous voltage.
- ★ Always route the power cord so that it is not likely to be walked on or pinched by other appliances. Never use extension cords.
- ★ Do not overload outlets with more than one appliance. This can result in fire or electrical shock.
- ★ Your model is equipped with a grounded and polarized plug. Do not defeat the purpose of this plug by removing the ground post or using a non-polarized adapter without properly grounding the outlet.
- ★ When a replacement part is required, always insist on factory authorized parts only.

## **MAINTENANCE**

### **PERIODIC CLEANING PROCEDURE**

It is best to clean your refrigerator when the product load is at its lowest level inside your cabinet. To clean the interior or exterior cabinet surfaces, the following procedure should be followed:

1. Disconnect your model from its power supply and remove all products from inside.
2. Open all doors and allow the cabinet to reach room temperature. Remove all accessories from within the model, wash with a baking soda and warm water solution, and rinse thoroughly with clear water. Dry all of the accessories completely with a soft clean cloth.
3. Once the cabinet has reached room temperature, wash the entire cabinet inside and out with a baking soda and warm water solution. For slightly more difficult cleanups, ammonia or vinegar in warm water can be used. Rinse thoroughly with clear water and dry with a soft clean cloth. Failure to dry all surfaces completely may cause water stains or streaking on the aluminum or stainless steel finish.
4. Return all accessories to their respective positions and return electric supply power to the model.

## **PRECAUTIONS**

1. Never use harsh detergents, cleaners, scouring powders, or chemicals when cleaning your model.
2. Strong bleaches tend to corrode many materials and should never come in contact with stainless steel.
3. Tincture of iodine, or iron should not come in contact with stainless steel. These solutions, which cause stainless steel to discolor, should be rinsed off immediately if contact occurs.
4. Some foods, such as mustard, mayonnaise, lemon juice, dressings or salts, may attack or corrode stainless steel.
5. Gritty, hard abrasives will mar the finish of stainless steel and aluminum and are not recommended.

## **GENERAL PREVENTATIVE MAINTENANCE**

Performance of the air-cooled condensing unit located inside of the compressor machine compartment of your new model, depends exclusively upon the amount of air passing through the condenser fins. Your refrigerator or freezer will run more efficiently, consume less current, and provide a maximum of trouble-free service throughout its lifetime if the condenser is kept clean and an adequate supply of clean, cool air is provided at all times. Periodically (at least once a month) inspect the condenser coil, which is located directly behind the rear panel grill, to check for debris or blockage.

If the condenser coil is dirty or blocked, disconnect the power supply to your model and using a stiff brush, brush the dirt from the condenser fins until the condenser is clear from any debris. Using a vacuum cleaner with a brush attachment may aid in this cleaning process. After cleaning, restore electrical service to your model.

## **PARTS AND SERVICE**

**Always** provide the cabinet model and serial number (located on the data plate on the inside right wall of the cabinet) whenever contacting the factory or your dealer regarding questions or when ordering parts.



## TROUBLESHOOTING AND SERVICING GUIDE

PROBLEM	PROBABLE CAUSE	CORRECTION
<p>Condensing unit will not start - no hum.</p>	<ol style="list-style-type: none"> <li>1.Line Disconnected, Switch Open.</li> <li>2.Fuse Removed Or Blown.</li> <li>3.Overload Protector Blown.</li> <li>4.Control "Off" Due To Cold Location.</li> <li>5.Control Stuck In Open Position.</li> <li>6.Wiring Improper Or Loose.</li> </ol>	<ol style="list-style-type: none"> <li>1.Close Start Or Disconnect Switch</li> <li>2.Replace Fuse.</li> <li>3.Determine Reason And Correct/Replace.</li> <li>4.Relocate Control</li> <li>5.Repair Or Replace Control.</li> <li>6.Check Wiring Against Diagram.</li> </ol>
<p>Condensing unit will not start - hums but trips on overload protector.</p>	<ol style="list-style-type: none"> <li>1.Improperly Wired.</li> <li>2.Low Voltage To Unit.</li> <li>3.Starting Capacitor Defective.</li> <li>4.Relay Failing To Close.</li> <li>5.Compressor Motor Has A Shorted Or Open Winding.</li> <li>6.Internal Mechanical Trouble In Compressor.</li> <li>7.Insufficient Air Supply.</li> </ol>	<ol style="list-style-type: none"> <li>1.Check Wiring Against Diagram</li> <li>2.Determine Reason And Correct.</li> <li>3.Determine Reason And Replace.</li> <li>4.Determine Reason And Replace.</li> <li>5.Replace Compressor.</li> <li>6.Replace Compressor.</li> <li>7.Clear Condenser &amp; Allow Compressor To Cool Down.</li> </ol>
<p>Condensing unit starts and runs, but short cycle on overload protector.</p>	<ol style="list-style-type: none"> <li>1.Additional Current Passing Through Overload Protector.</li> <li>2.Low Voltage To Unit.</li> <li>3.Overload Protector Defective.</li> <li>4.Run Capacitor Defective.</li> <li>5.Excessive Discharge Pressure.</li> <li>6.Excessive Suction Pressure.</li> <li>7.Insufficient Air Supply</li> </ol>	<ol style="list-style-type: none"> <li>1.Check Wire Diagram Check For Added Components Connected To Wrong Side Of Overload Protector</li> <li>2.Determine Reason And Correct.</li> <li>3.Check Current, Replace Protector.</li> <li>4.Determine Reason And Replace.</li> <li>5.Check Ventilation, Restrictions In Cooling Medium Or Refrig. System.</li> <li>6.Check For Misapplication.</li> <li>7.Clear Condenser &amp; Allow Compressor To Cool Down.</li> </ol>
<p>Condensing unit starts, but fails to switch off of "start" winding.</p>	<ol style="list-style-type: none"> <li>1.Improperly Wired.</li> <li>2.Low Voltage To Unit.</li> <li>3.Relay Failing To Open.</li> <li>4.Run Capacitor Defective.</li> <li>5.Excessively High Discharge Pressure.</li> <li>6.Compressor Motor Has A Shorted Or Open Winding.</li> <li>7.Internal Mechanical Trouble In Compressor.</li> </ol>	<ol style="list-style-type: none"> <li>1.Check Wiring Against Diagram.</li> <li>2.Determine Reason And Correct.</li> <li>3.Determine Reason And Replace.</li> <li>4.Determine Reason And Replace.</li> <li>5.Check Discharge Shut-Off Valve, Possible Overcharge.</li> <li>6.Replace Compressor.</li> <li>7.Replace Compressor.</li> </ol>

PROBLEM	PROBABLE CAUSE	CORRECTION
Condensing unit runs, but short cycles on:	1. Overload Protector. 2. Thermostat. 3. High Pressure Cut -Out Due To: (a) Insufficient Air Supply. (b) Overcharge. (c) Air In System 4. Low Pressure Cut - Out Due To: (a) Valve Leak  (b) Undercharge. (c) Restriction In Expansion Device.	1. See Problem # 3. 2. Differential Must Be Widened. 3. (a) Check Air Supply To Condenser (b) Evacuate And Re-Charge. (c) Evacuate And Re-Charge. 4. (a) Replace, Evacuate And Re-Charge. (b) Evacuate And Re-Charge. (c) Replace Expansion Device.
Condensing unit runs, but for prolonged periods or continuous.	1. Shortage Of Refrigerant. 2. Control Contacts Stuck Closed. 3. Excessive Heat Load Placed Into Cabinet.  4. Prolonged Or Too Frequent Door Openings.  5. Evaporator Coil Iced. 6. Restriction In Refrigeration System. 7. Dirty Condenser. 8. Filter Drier Clogged.	1. Fix Leak, Evacuate And Re-Charge. 2. Clean Contacts Or Replace Control. 3. Allow Unit Sufficient Time For Removal Of Latent Heat. 4. Plan Or Organized Schedule To Correct Condition. 5. Defrost Evaporator Coil. 6. Determine Location And Remove. 7. Clean Condenser Coil. 8. Replace, Evacuate And Re-Charge.
Start capacitor open shorted or blown.	1. Relay Contact Not Opening Properly. 2. Prolonged Operation On Start Cycle: (a) Low Voltage To Unit (b) Improper Relay. (c) Starting Load Too High. 3. Excessive Short Cycling.  4. Improper Capacitor.	1. Clean Contacts Or Replace Relay. 2. (a) Determine Reason And Correct. (b) Replace With Correct Relay. (c) Correct By Using Pump Down. 3. Determine Reason For Short Cycle, (See Problem # 5) And Correct. 4. Determine Correct Size And Replace.
Run capacitor open, shorted or blown.	1. Incorrect Relay. 2. Excessively High Line Voltage, Over 110% Of Rated Maximum.	1. Check Size And Replace. 2. Determine Reason And Correct.
Relay defective or blown out.	1. Incorrect Relay 2. Incorrect Mounting Angle. 3. Voltage Too low Or Too High. 4. Excessive Short Cycling.  5. Loose Or Vibrating Mounting Position. 6. Incorrect Run Capacitor. 7. Loose Wiring On Relay Or Overload.	1. Check Relay And Replace. 2. Remount Relay In Correct Position. 3. Determine Reason And Correct. 4. Determine Reason And Correct (See Problem # 5). 5. Remount Rigidly. 6. Replace With Proper Capacitor. 7. Tighten All Wiring Screws.

<b>PROBLEM</b>	<b>PROBABLE CAUSE</b>	<b>CORRECTION</b>
Product zone temperature too high.	<ol style="list-style-type: none"> <li>1.Control Setting Too High.</li> <li>2.Inadequate Air Circulation.</li> <li>3.Dirty Condenser.</li> </ol>	<ol style="list-style-type: none"> <li>1.Adjust T-Stat.</li> <li>2.Rearrange Product Load To Improve Air Circulation.</li> <li>3.Clean Condenser Coil.</li> </ol>
Suction line frosted or sweating.	<ol style="list-style-type: none"> <li>1.Overcharge Of Refrigerant.</li> <li>2.Evaporator Fan Not Running.</li> <li>3.Expansion Valve Stuck Open.</li> <li>4.Expansion Valve Superheat Too Low.</li> </ol>	<ol style="list-style-type: none"> <li>1.Evacuate And Re-Charge.</li> <li>2.Determine Reason And Correct.</li> <li>3.Clean Valve, Evacuate And Re-Charge.</li> <li>4.Adjust Superheat To Required Setting.</li> </ol>
Liquid line frosted , cold, or sweating.	<ol style="list-style-type: none"> <li>1.Restriction In Drier Strainer.</li> <li>2.Liquid Line Service Valve Partially Closed.</li> </ol>	<ol style="list-style-type: none"> <li>1.Replace Drier, Evacuate And Re-Charge.</li> <li>2.Open Valve Fully Or Replace If Necessary.</li> </ol>
Noisy condensing unit.	<ol style="list-style-type: none"> <li>1.Loose Parts Or Mountings.</li> <li>2.Tubing Rattle Or Vibration.</li> <li>3.Bent Fan Blade Causing Excessive Vibration.</li> <li>4.Fan Motor Bearings Worn.</li> </ol>	<ol style="list-style-type: none"> <li>1.Tighten All Mounting Parts And Shroud Cover.</li> <li>2.Reform Tubing To Be Free Of Contact.</li> <li>3.Replace Fan Blade.</li> <li>4.Replace Fan Motor.</li> </ol>
Thermometer reads different than actual temperature.	<ol style="list-style-type: none"> <li>1.Calibration.</li> <li>2.Defective.</li> </ol>	<ol style="list-style-type: none"> <li>1.Consult Operations Manual And Calibrate.</li> <li>2.Replace.</li> </ol>
Water leaks inside unit.	<ol style="list-style-type: none"> <li>1.Condensate Drain Pan Not Installed Properly.</li> <li>2.Unit Not Level.</li> <li>3.Drain Pan Misaligned.</li> <li>4.Defective Drain Pan.</li> </ol>	<ol style="list-style-type: none"> <li>1.Consult Operation Manual For Install Instruction.</li> <li>2.Make Sure Unit Is Level Or Pitched Back Slightly.</li> <li>3.Make Sure Drain Pan Is Aligned Properly.</li> <li>4.Replace.</li> </ol>
Doors Misaligned.	<ol style="list-style-type: none"> <li>1.Shifted During Shipping.</li> </ol>	<ol style="list-style-type: none"> <li>1.Refer To Operation Manual For Hinge Adjustment.</li> </ol>



# WIRING DIAGRAMS

## SELF-CONTAINED UNDERCOUNTER REFRIGERATOR 115/60/1 WD-R5

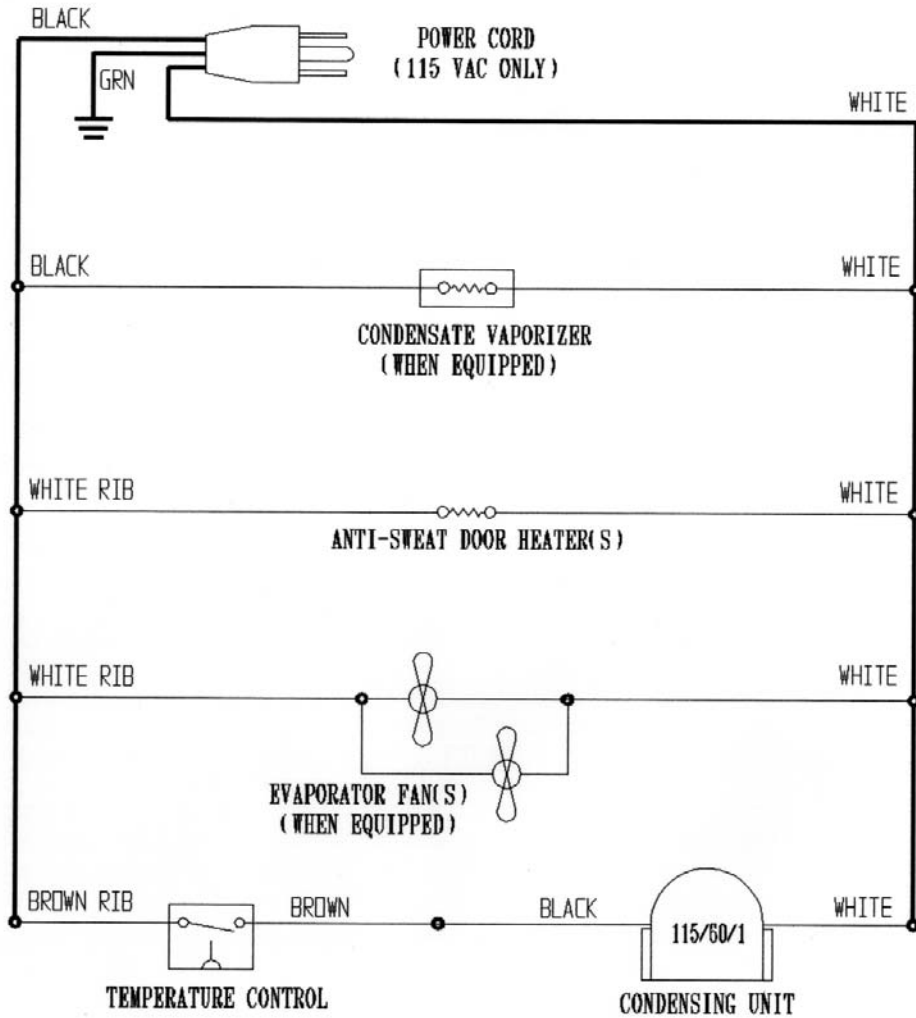

**Continental** REFRIGERATOR  
A Division of National Refrigeration & A/C Products, Inc.

# Continental

---

---

## Refrigerator

### Continental Warranty Procedure

Continental's warranty is 1 year on parts and labor, and 5 years on the compressor, from the date of original installation on any unit.

Please consult the factory before any warranty service work is completed. **Exceptions will be made.** For example; after hours, you must contact the factory at 1-800-523-7138 at extension 113 or 134. You **MUST** provide the model and **serial number**, place of business, where the unit is located and if possible the installation date. Contact the factory the following business day, during normal business hours 8 A.M. to 5 P.M. eastern time, to follow up with Continental's service department.

The customer has the freedom of using any certified technician for the warranty service. The service company's information, such as, name, address, phone and fax numbers, must be provided. The invoice may be faxed or mailed to the address listed below for payment; however, Continental has the right to contact the service company with questions on any unnecessary, excessive charges.

Not all items are covered under warranty, such as, temperature adjustments, calibration, leveling, dirty condensers, any preventive maintenance and any misapplication i.e. not enough ventilation.

Please consult the factory for any parts or questions regarding the above warranty procedures.

Thank You,  
Parts and Service

# Continental

---

---

## Refrigerator

### Warranty Compressor Procedures

If the compressor fails within the first (12) months of use or (20) months by the date code on the compressor, an “over-the-counter exchange” must be made through a Tecumseh or Copeland dealer.

After the first year the additional (4) year compressor warranty is through Continental Refrigeration, and can be handled by one of the following methods:

- (1) Continental will supply the replacement compressor at no charge and pay for regular ground freight.
- (2) Continental will supply the compressor at no charge and the end user, dealer or service company pays for the freight, other than regular ground (COD, Visa or Mastercard).
- (3) A compressor can be purchased locally and Continental will either replace the compressor for stock or offer an allowance towards its purchase. The end user is to pay the difference:

- (A)  $\frac{1}{5}$  h.p. to  $\frac{1}{3}$  h.p.-Up to \$100
- (B)  $\frac{1}{2}$  h.p. to  $\frac{3}{4}$  h.p.-Up to \$250
- (C) 1 h.p. to 2 h.p.-Up to \$350

Exceptions will be made depending on circumstances, but in all cases, Continental must be notified prior to any transaction, if possible. The tag from the defective compressor or the information (if unable to remove) must be returned for proof of failure after the first year. Please contact the service department with any further questions.

Thank You,  
The Service Department

# Continental

---

---

## Refrigerator

### Items NOT Covered Under Warranty:

**Consult your owner's manual for detailed information on the following: (page #'s listed beside each line item).**

- I. Preventative Maintenance
  - A. Dirty Condenser (13)
  - B. General Hardware Adjustments
    - 1. Casters/Legs (3)
    - 2. Handles
    - 3. Hinges
    - 4. Light Bulb Replacement
- II. Compressor Failure Due to Poor Air Circulation
  - A. Reach-In, Roll-In Models, Warmers (White)\*
    - 1. 12" Above Grill Area (2-3)
    - 2. 3" On Sides, Back & Underneath (Reach-In only) (2-3)
  - B. Backbar, Keg, Bottle Cooler Units & Glass, Plate Chiller Units (Green)\*
    - 1. 3" On Sides & Back (2-3)
  - C. Undercounter, Sandwich & Pizza Prep Units (Yellow)\*
    - 1. 3" On Sides, Back & Underneath (2-4)
  - D. Front Breather Units (Yellow)\*
    - 1. Minimal Ventilation Needed
  - E. Milk Coolers (Blue)\*
    - 1. 3" On Sides, Back & Underneath (3)
- III. Temperature Adjustments / Calibrations (8-11)
- IV. Leveling (2-3)

**\*\* FAILURES DUE TO LACK OF MAINTENANCE, POOR INSTALLATION OR INAPPROPRIATE OPERATION OF THE UNIT MAY VOID CUSTOMER'S WARRANTY\*\***

**Please contact the Service Dept. with any questions pertaining to the above.**

\*Color of owner's manual.

Thank You,  
The Service Dept

A DIVISION OF NATIONAL REFRIGERATION & A/C PRODUCTS, INC.  
539 Dunksferry Road Bensalem, Pennsylvania 19020-5908  
Phone (215) 244-1400 (800) 523-7138 Fax (215) 244-9579  
[www.continentalrefrigertor.com](http://www.continentalrefrigertor.com)

