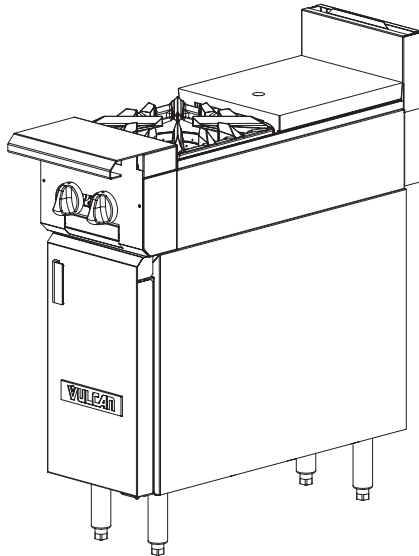

**HEAVY DUTY COOKING****VULCAN****HEAVY DUTY GAS RANGE  
1-BURNER FRONT / 1-HALF HOT TOP REAR  
12" WIDE GAS RANGE**

**Model V1BH12B**  
(shown on cabinet base)

**SPECIFICATIONS**

12" wide heavy duty gas range, Vulcan Model No. V1BHT12 (modular) and V1BH12B (cabinet base). Stainless steel front, sides, plate ledge, front top ledge with pull-out condiment rails, exterior bottom and stub back. 1/4" diameter front gas manifold. Heavy cast aeration bowls with removable cast top grates. Front grate: 11½" x 11½", rear grate: 11½" x 14". One 33,000 BTU/hr. heavy cast, two-piece open burners with individual pilots and one 18,000 BTU/hr. half hot top burners with individual pilots. Total input 51,000 BTU/hr.

**Exterior Dimensions:**

36¾"d x 12"w x 36"h on 6" adjustable legs

- V1BHT12** 1-Burner / 1-Half Hot Top / Modular
- V1BH12B** 1-Burner / 1-Half Hot Top / Cabinet Base

**STANDARD FEATURES**

- Stainless steel front, front top ledge, burner box, sides base, exterior bottom and stub back
- 1¼" diameter front gas manifold (Not available with rear gas)
- 33,000 BTU/hr. open top burners with lift off heads
- 18,000 BTU/hr. half-hot top burners
- Individual pilots and controls for each burner
- Heavy-duty cast grates
- 4" stainless steel stub riser
- 6" adjustable stainless steel legs for floor models (no legs for modular model)
- Stainless steel cabinet base door
- One year limited parts and labor warranty

**OPTIONAL FEATURES** (Factory Installed)

- Cap and cover front manifold, left or right only, not both
- 4" adjustable feet for modular models
- 6" adjustable flanged feet for cabinet base models
- Less legs for dolly mounting of cabinet base models
- Set of 4 casters. 6" high (two locking)
- 3" high toe base for curb mounting of cabinet base models
- ¾", 1", or 1¼" gas pressure regulator (specify gas type – pack loose)

**ACCESSORIES** (Packaged & Sold Separately)

- Banking strip
- 10", 22", or 34" high back risers (no shelf)
- 22" single deck solid or flo-thru high shelf risers
- 34" double deck solid or flo-thru high shelf risers
- Flexible gas hose with quick disconnect and restraining device

**VULCAN**

a division of ITW Food Equipment Group LLC

P.O. Box 696 ■ Louisville, KY 40201 ■ Toll-free: 1-800-814-2028 ■ Local: 502-778-2791 ■ Quote & Order Fax: 1-800-444-0602



**HEAVY DUTY GAS RANGE**  
**1-BURNER FRONT / 1-HALF HOT TOP REAR**  
**12" WIDE GAS RANGE**

**INSTALLATION INSTRUCTIONS**

1. A properly sized gas pressure regulator suitable for battery or single unit application must be furnished and installed. Natural gas 6.0" W.C., propane gas 10 W.C.
2. An adequate ventilation system is required for commercial cooking equipment. Information may be obtained by writing to the National Fire Protection Association, 1 Batterymarch Park, Quincy, MA 02269, www.NFPA.org. When writing, refer to NFPA No. 96.
3. These units are manufactured for installation in accordance with ANSZ223.1A (latest edition), National Fuel Gas Code. Copies may be obtained from The American Gas Association, 400 N Capitol St. NW, Washington, DC 20001, www.AGA.org.

5. For proper combustion, install equipment on adjustable legs or casters. On curb or platform, allow 3½" front overhand. Toe base with leveling bolts are required for curb installation. Specify when ordering.
6. Cannot be battered with GH series equipment.
7. This appliance is manufactured for commercial installation only and is not intended for home use.

**NOTE:** In line with its policy to continually improve its product, Vulcan reserves the right to change materials and specifications without notice.

4. Clearances	Rear	Sides
Combustible	10"	10"
Non-combustible	0"	0"

**Specify type of gas when ordering.**  
**Specify altitude when above 2,000 feet.**

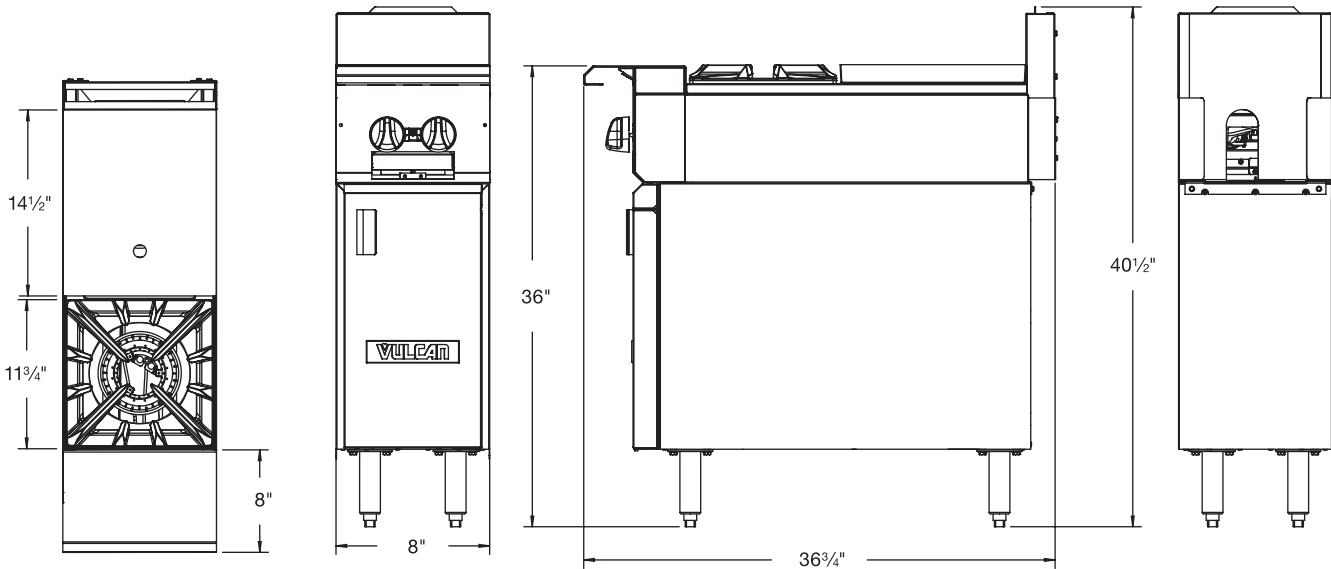

TOP CONFIGURATION	MODEL NUMBER	DESCRIPTION	TOTAL INPUT BTU / HR	SHIPPING WEIGHT LBS / KG
	<b>V1BHT12</b>	1-Burner / 1-Half Hot Top Rear / Modular	51,000	220 / 100
	<b>V12BH12B</b>	1-Burner / 1-Half Hot Top Rear / Cabinet Base	51,000	285 / 129

This appliance is manufactured for commercial use only and is not intended for home use.



a division of ITW Food Equipment Group LLC

P.O. Box 696 ■ Louisville, KY 40201 ■ Toll-free: 1-800-814-2028 ■ Local: 502-778-2791 ■ Quote & Order Fax: 1-800-444-0602

**NOTE:** In line with its policy to continually improve its products, Vulcan reserves the right to change materials and specifications without notice.