



**TRUE FOOD SERVICE EQUIPMENT, INC.**

2001 East Terra Lane • P.O. Box 970 • O'Fallon, Missouri 63366  
 (636)240-2400 • Fax (636)272-2408 • (800)325-6152 • Intl Fax# (001)636-272-7546  
 Parts Dept. (800)424-TRUE • Parts Dept. Fax# (636)272-9471 • www.truemfg.com

Project Name: \_\_\_\_\_

Location: \_\_\_\_\_

Item #: \_\_\_\_\_ Qty: \_\_\_\_\_

Model #: \_\_\_\_\_

A/A #

SIS #

Model:  
**GEM-12FC**

**Glass End Floral Case:**  
*Swing Door Refrigerator*



**GEM-12FC**

- ▶ Glass end models offer greater product visibility for more attractive displays.
- ▶ Oversized and balanced refrigeration system, factory sealed and pre-lubricated for long life. Designed to hold 35°F (1.6°C) to accommodate a broad range of floral arrangements.
- ▶ Exterior - non-peel or chip black laminated vinyl; durable and permanent.
- ▶ Interior - attractive, NSF approved, black aluminum interior liner with 300 series stainless steel floor.
- ▶ Self closing door. Positive seal, torsion type closure system.
- ▶ "Low-E", double pane thermal insulated glass side panel and door assemblies with mitered plastic channel. The latest in energy efficient technology.
- ▶ Special interior agro lighting designed for flowers to prevent premature discoloration.
- ▶ Door sign decal.
- ▶ Entire cabinet structure is foamed-in-place using Ecomate. A new, innovative, high density, polyurethane insulation that has zero ozone depletion potential (ODP) and zero global warming potential (GWP).

**Bottom mounted units feature**

- ▶ "No stoop" lower shelf to maximize product visibility
- ▶ Storage on top of cabinet.
- ▶ Easily accessible condenser coil for cleaning.

**ROUGH-IN DATA**

Specifications subject to change without notice.  
 Chart dimensions rounded up to the nearest 1/8" (millimeters rounded up to next whole number).

Model	Doors	Capacity (Cu. Ft.) (liters)	Shelves	Cabinet Dimensions (inches) (mm)			HP	Voltage	Amps	NEMA Config.	Cord Length (total ft.) (total m)	Crated Weight (lbs.) (kg)
				L	D†	H						
GEM-12FC	1	12 340	2	24 7/8	23	62 1/2	1/5	115/60/1	5	5-15P	9	250
				632	585	1588	1/4	230-240/50/1	3.0	▲	2.74	114

† Depth does not include 1 3/8" (35 mm) for door handle.

▲ Plug type varies by country.



Printed in U.S.A.

APPROVALS:

AVAILABLE AT:

Model:  
**GEM-12FC**

## Glass End Floral Case: Swing Door Refrigerator



### STANDARD FEATURES

#### DESIGN

- True's commitment to using the highest quality materials and refrigeration systems provides the user with dependable product temperatures, and lower utility costs in an attractive merchandiser that brilliantly displays high profit floral arrangements.
- True's floral merchandisers offer interior agro lighting combined with a baffled airflow design which creates the ideal environment to prolong fresh flower shelf life. Brilliant black exterior and interior with product accentuating black shelves further entice customers to purchase high profit floral arrangements.

#### REFRIGERATION SYSTEM

- Factory engineered, self-contained, capillary tube system using environmentally friendly (CFC free) 134A refrigerant.
- Oversized and balanced refrigeration system, factory sealed and pre-lubricated for long life. Designed to hold 35°F (1.6°C) to accommodate a broad range of floral arrangements.
- Sealed, cast iron, self-lubricating evaporator fan motor(s) and larger fan blades give True merchandisers a more efficient low velocity, high volume airflow design. This unique design ensures faster temperature pull down, dependable holding temperatures and faster recovery in high use situations.
- Bottom mounted condensing unit positioned for easy maintenance; "no stoop" lower shelf maximizes visibility by raising merchandised product to a higher level.
- Baffled airflow provides even air distribution for longer shelf life of fresh flowers.

#### CABINET CONSTRUCTION

- Exterior - non-peel or chip black laminated vinyl; durable and permanent.
- Interior - attractive, NSF approved, black aluminum liner with 300 series stainless steel floor.
- Insulation - entire cabinet structure is foamed-in-place using Ecomate. A new, innovative, high density, polyurethane insulation that has zero ozone depletion potential (ODP) and zero global warming potential (GWP).

- Welded, heavy duty steel frame rail, black powder coated for corrosion protection.
- Frame rail fitted with leg levelers.
- Door sign decal.

#### DOOR

- "Low-E", double pane thermal insulated glass door assembly with mitered plastic channel frame. The latest in energy efficient technology.
- Door fitted with 12" (305 mm) long PVC handle.
- Self closing door. Positive seal, torsion type closure system.
- Magnetic door gasket of one piece construction, removable without tools for ease of cleaning.

#### SHELVING

- Two (2) adjustable, heavy duty, black PVC coated wire shelves 20<sup>5</sup>/<sub>16</sub>" L x 17<sup>1</sup>/<sub>2</sub>" D (601 mm x 445 mm). Four (4) chrome plated shelf clips included per shelf.
- Shelf support pilasters made of same material as cabinet interior; shelves are adjustable on 1/2" (13 mm) increments.

#### LIGHTING

- Fluorescent interior lighting. Safety shielded.
- Special interior agro lighting designed for flowers to prevent premature discoloration.
- Cabinet lighting utilizes electronic ballast and T-8 bulbs for brighter illumination, longer bulb life and increased energy efficiency.

#### MODEL FEATURES

- Evaporator is epoxy coated to eliminate the potential of corrosion.

#### ELECTRICAL

- Unit completely pre-wired at factory and ready for final connection to a 115/60/1 phase, 15 amp dedicated outlet. Cord and plug set included.



115/60/1  
NEMA-5-15R

#### OPTIONAL FEATURES/ACCESSORIES

Upcharge and lead times may apply.

- 230 - 240V / 50 Hz.
- White exterior.
- Rosewood exterior.
- Mirrored back.
- 2<sup>1</sup>/<sub>2</sub>" (64 mm) diameter castors.
- Barrel locks.
- Additional shelves.
- Remote cabinets (condensing unit supplied by others; system comes standard with 404A expansion valve and requires R404A refrigerant). Consult factory technical service department for BTU information.

### PLAN VIEW

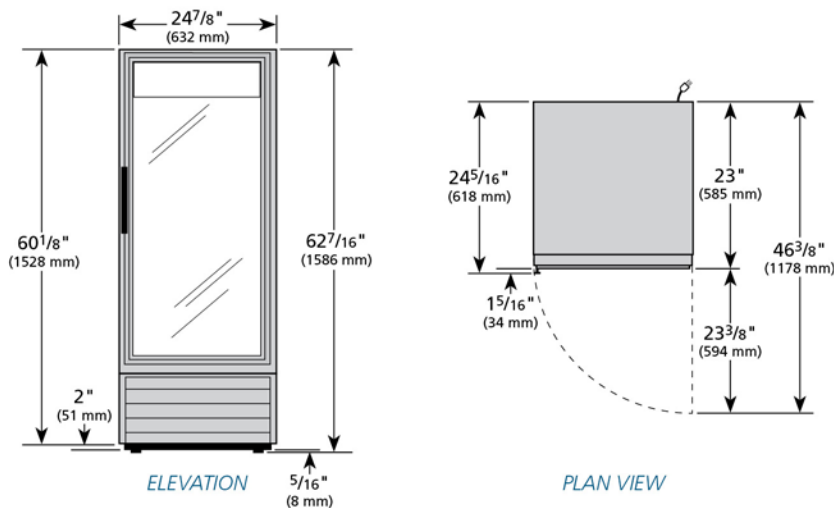

#### WARRANTY

One year warranty on all parts and labor and an additional 4 year warranty on compressor. (U.S.A. only)

METRIC DIMENSIONS ROUNDED UP TO THE NEAREST WHOLE MILLIMETER

SPECIFICATIONS SUBJECT TO CHANGE WITHOUT NOTICE



Model	Elevation	Right	Plan	3D	Back
GEM-12FC	TFAY56E	TFAY56S	TFAY56P	TFAY563	

### TRUE FOOD SERVICE EQUIPMENT