



Our M-95 series bun grill toasters can toast up to 1,296 4" bun halves every hour depending on desired browning. Browning can be controlled with an available 35, 45, or 55 second gears depending on the model.

A patented self-leveling conveyor automatically adjusts to various sizes of buns, bagels, and Texas toast. The large butter roller and pan covers buns with just the right amount of butter to match your recipe.

Operators can adjust the heat with the thermostatic controls from 200 to 500 degrees.

The heavy-duty stainless steel construction is built solid for high output and long life.

OPTIONS

- PTFE Sheet Kit (10) sheets M-95-2 (3T-M2-PTFEKIT) M-95-3 (3T-M3-PTFEKIT)
- Recommend using PTFE sheets for buns being toasted without any clear (whirl) food oil (dry toasting) or with high protein butters (garlic butter, or butter with cheese in it)
- Bun slide (collects buns and butter)
- Toasters can be ordered with various gear packages depending on your operation's needs or you can retrofit an existing toaster to a different speed in the field. (consult the factory)

WARRANTY

APW Wyott bun grill toasters are backed by a 1-year parts and labor warranty, including on-site service calls within 50 miles of authorized service technicians.

CERTIFICATIONS

Certified by the following agencies:



FEATURES AT A GLANCE

- The M-95-2 Bun Grill toaster can generate up to 865 bun halves per hour (35 second gear) and M-95-3 Bun Grill can generate up to 1,296 bun halves per hour
- M-95-3 and/or the M-95-2 toasters are available with 35, 45, or 55 second gears. Gears allow your operation to select speeds that result in your desired toasted bun surface and internal bun temperatures
- Fast heat-up allows your operation to react to surges in volume
- Toasters come with extended super-feeder to allow for high volume production
- Patented self-leveling conveyor automatically adjusts to various sizes of buns, bagels, and Texas toasts
- Butter roller and pan consistently covers buns with the perfect amount of butter
- Durable stainless steel griddle plate is thermostatically controlled between 200 to 500 degrees
- Removable side panel allows easy access for service
- Removable conveyor paddle system allows internal cleaning of the conveyor (power soaking) and the griddle plate (spray cleaner and pads)
- Compact, vertical design allows unit to fit into tight counter areas
- Stainless steel construction for long life and high volume production
- Use wet or dry
- 4" adjustable legs
- M-95-2 comes standard with two PTFE sheets
- M-95-3 does not come standard with PTFE sheets

EQUIPMENT DIMENSIONS

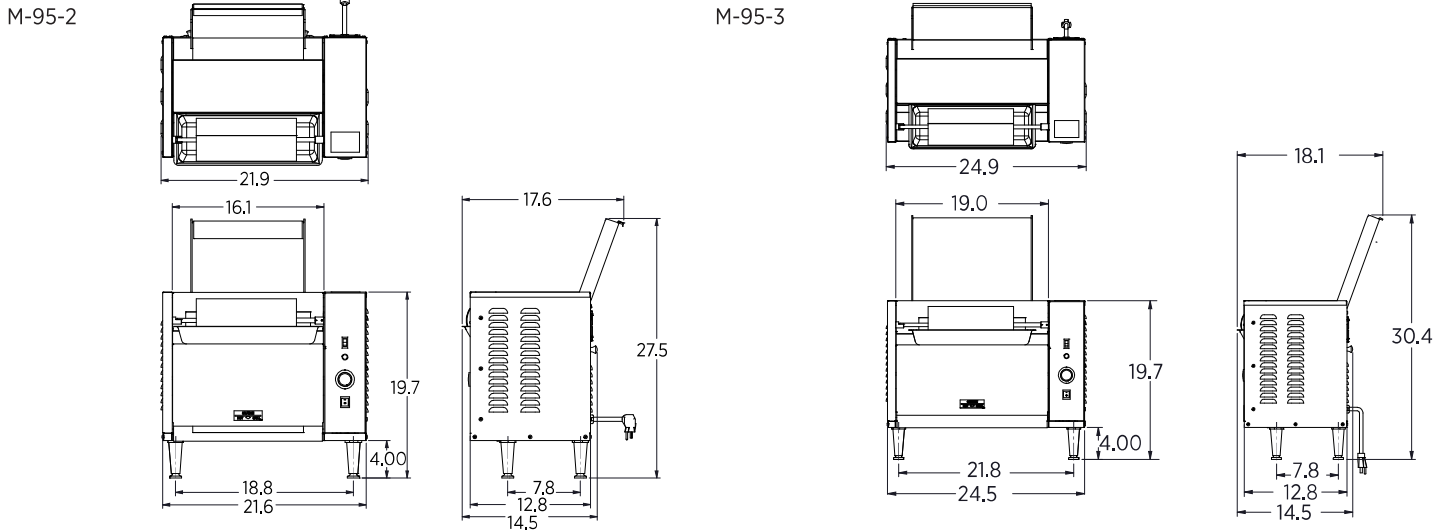

MECHANICAL SPECIFICATIONS

Model #	Overall Dimensions Width x Height x Depth (inches / mm)	Volts	Watts	Amps	Gears	Ship Weight (lbs. / Kilos)
M-95-2	21.9" x 27.5" x 17.6" (556 x 699 x 447)	120	1,800	15.0	35, 45, or 55	97 lbs. (44 kg)
	21.9" x 27.5" x 17.6" (556 x 699 x 447)	208	2,780	13.4	35 or 55	97 lbs. (44 kg)
	21.9" x 27.5" x 17.6" (556 x 699 x 447)	240	2,780	11.6	35 or 55	97 lbs. (44 kg)
M-95-2 CE	21.9" x 27.5" x 17.6" (556 x 699 x 447)	230	2,550	11.1	35 or 55	97 lbs. (44 kg)
M-95-3	24.9" x 30.4" x 18.1" (632 x 772 x 460)	120	1,800	15.0	35, 45, or 55	105 lbs. (47.62 kg)
	24.9" x 30.4" x 18.1" (632 x 772 x 460)	208	2,780	13.4	35, 45, or 55	105 lbs. (47.62 kg)
	24.9" x 30.4" x 18.1" (632 x 772 x 460)	240	2,780	11.6	35, 45, or 55	105 lbs. (47.62 kg)
M-95-3 CE	24.9" x 30.4" x 18.1" (632 x 772 x 460)	230	2,550	11.1	35	105 lbs. (47.62 kg)

GEARS

Model #	4" Bun with 35 second gear	4" Bun with 45 second gear	4" Bun with 55 second gear	5" Bun with 35 second gear	5" Bun with 45 second gear	5" Bun with 55 second gear
M-95-2	864 per hour	673 per hour	545 per hour	692 per hour	692 per hour	436 per hour
M-95-3	1,296 per hour	1,010 per hour	818 per hour	1,038 per hour	1,038 per hour	654 per hour

ELECTRICAL INFORMATION

US units (North America): 120V:NEMA 5-20P Plug, 3 wire grounded cord; 208/250V:NEMA 6-20P Plug, 3 wire grounded cord. CE units (Europe): PLUG; CEE 7/7 CONT. EUR. 16AMP grounded plug w/ 250V 16 Amp cord. UK units (England): PLUG; BS1363 UK 13AMP W/FUSE grounded w/ 250V 16 Amp cord.

REQUIRED CLEARANCES

	Combustible
Left	0" (0 mm)
Right	0" (0 mm)
Back	0" (0 mm)

Freight Class: 100
 FOB: Smithville, 37166