



**TRUE FOOD SERVICE  
EQUIPMENT, INC.**

2001 East Terra Lane • P.O. Box 970 • O'Fallon, Missouri 63366  
(636)240-2400 • Fax (636)272-2408 • (800)325-6152 • Intl Fax# (001)636-272-7546  
Parts Dept. (800)424-TRUE • Parts Dept. Fax# (636)272-9471 • www.truemfg.com

Project Name: \_\_\_\_\_

Location: \_\_\_\_\_

Item #: \_\_\_\_\_ Qty: \_\_\_\_\_

Model #: \_\_\_\_\_

A/A #

S/S #

Model:  
**TR1HRT-1S-1S**

**TR Spec Series:**  
*Roll-Thru Solid Swing Door Heated Cabinet*



**TR1HRT-1S-1S**

- ▶ Roll-thru heated cabinet designed to be rear-loaded from kitchen prep area and front accessed for quick, efficient food service.
- ▶ Provides cabinet holding temperature of 80°F to 180°F (26.6°C to 82.2°C).
- ▶ Equipped with low-velocity fans to assure even temperature distribution throughout the cabinet. Fans are controlled by exterior on/off switch.
- ▶ Two (2) stainless steel, finned tube heating elements (1000 watts each) for uniform generation of electric heat. Cabinet comes with a total of 2000 watts.
- ▶ 300 series stainless steel exterior front, back, bottom and interior. The very finest stainless with higher tensile strength for fewer dents and scratches.
- ▶ Three (3) lifetime guaranteed, cam-lift hinges per door. Full 180° open capability with a stay open feature at 120°.
- ▶ Designed to accept roll-in racks (inboard castors) with a maximum dimension of 27"L x 29"D x 66"H (686 mm x 737 mm x 1677 mm). One (1) heavy gauge stainless steel ramp standard per door.
- ▶ Insulation - entire cabinet structure and solid doors are foamed-in-place using Ecomate. A new, innovative, high density, polyurethane insulation that has zero ozone depletion potential (ODP) and zero global warming potential (GWP).

**ROUGH-IN DATA**

Specifications subject to change without notice.  
Chart dimensions rounded up to the nearest 1/8" (millimeters rounded up to next whole number).

Model	Doors	Capacity (Cu. Ft.) (liters)	Cabinet Dimensions (inches) (mm)			Watts	Voltage	NEMA Config.	Cord Length (total ft.) (total m)	Crated Weight (lbs.) (kg)
			L	D†	H*					
TR1HRT-1S-1S	1 fr / 1 bk	37 1048	35 889	36 7/8 937	83 3/4 2128	2000	115/60/1	14-20P	9 2.74	N/A N/A

† Depth does not include 4 1/4" (7 mm) for ramp.  
\* Height does not include 1" (26 mm) for system mechanical components.  
Requires 115/208-240/60 Hz, single phase, 3 pole, 4 wire circuit.

	<b>APPROVALS:</b>	<b>AVAILABLE AT:</b>
	Printed in U.S.A.	

Model:  
**TR1HRT-1S-1S**

**TR Spec Series:**  
Roll-Thru Solid Swing Door Heated Cabinet



**STANDARD FEATURES**

**DESIGN**

- True's solid door roll-thru heated cabinets are designed with enduring quality that protects your long term investment.

**HEATER SYSTEM**

- Cabinet is designed to provide holding temperatures of 80°F to 180°F (26.6°C to 82.2°C). Heating system controlled by exterior on/off switch and temperature control dial.
- Two (2) stainless steel (for corrosion resistance), finned tube heating elements (1000 watts each) for uniform generation of electric heat. Cabinet comes with a total of 2000 watts.
- Equipped with low-velocity fans to assure even temperature distribution throughout the cabinet. Fans are controlled by exterior on/off switch.
- Manually controlled vent located on top of the cabinet for positive humidity control.

**CABINET CONSTRUCTION**

- Exterior - 300 series stainless steel doors, front, back and bottom. Stainless steel sides.
- Interior - 300 series stainless steel liner and floor.
- Stainless steel breaker caps.
- Insulation - entire cabinet structure and solid doors are foamed-in-place using Ecomate. A new, innovative, high density, polyurethane insulation that has zero ozone depletion potential (ODP) and zero global warming potential (GWP).
- One (1) heavy gauge stainless steel ramp per door.
- Designed to accept roll-in racks (inboard castors) with a maximum dimension of 27"L x 29"D x 66"H (686 mm x 737 mm x 1677 mm).

**DOORS**

- 300 series stainless steel exterior and liners. Doors open within cabinet dimension.
- Door locks standard.
- Lifetime guaranteed recessed door handles. Each door fitted with 12" (305 mm) long recessed handle that is foamed-in-place with a sheet metal interlock to ensure permanent attachment.

- Three (3) lifetime guaranteed, cam-lift hinges per door. Full 180° open capability with a stay open feature at 120°.
- Magnetic door gaskets of one piece construction, removable without tools for ease of cleaning.
- Wiper gaskets for positive seal, reversible.
- Doors are field reversible.

**SHELVING**

**LIGHTING**

- Incandescent interior lighting; lights activated by exterior on/off switch, safety shielded.

**MODEL FEATURES**

- Exterior, color coded, temperature display; accurate direct reading of internal cabinet temperature.
- Designed to hold warm baked or cooked food. Cabinet is not designed to heat ambient or cold product.
- Interior bumpers protect cabinet walls from abuse caused by roll-in carts.
- 12" x 20" (305 mm x 508 mm) pan for water included, if additional humidity is required.
- NSF-4 compliant for open food product.

**ELECTRICAL**

- True requires that a sole use circuit be dedicated for the unit.
- Unit completely pre-wired at factory and ready for final connection to a 115/208-240/60 Hz. single phase, 20 amp dedicated outlet. Cord and plug set included.



115/208-230/1  
NEMA-14-20R

**OPTIONAL FEATURES/ACCESSORIES**

Upcharge and lead times may apply.

- Metal door handles (factory installed).
- Electronic temperature control (factory installed).
- Correctional facilities options.

**PLAN VIEW**

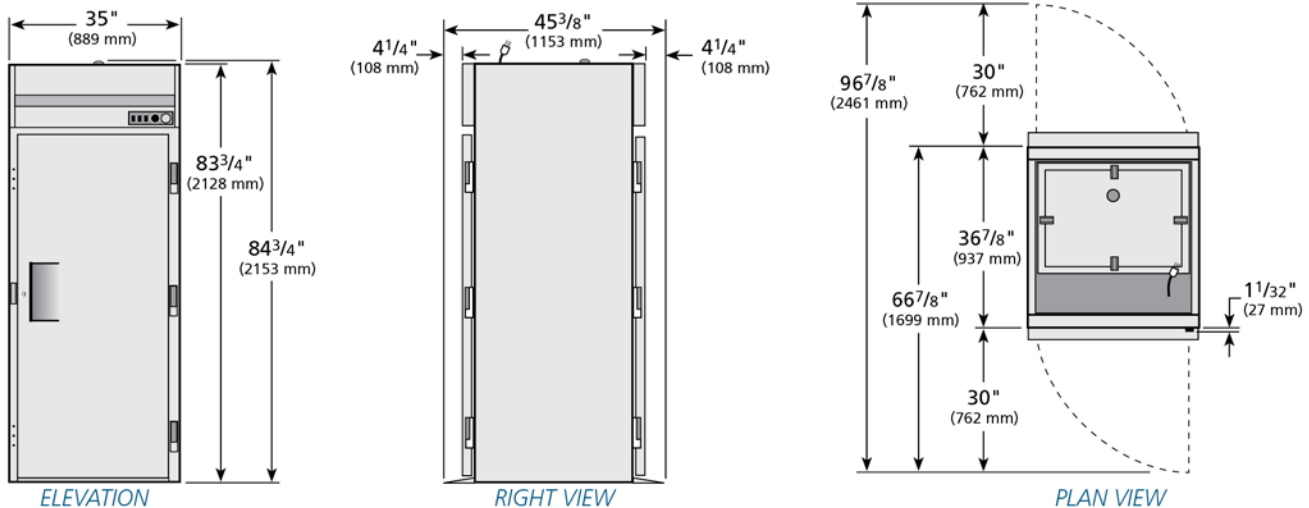

**WARRANTY**  
One year warranty on all parts and labor. (U.S.A. only)

METRIC DIMENSIONS ROUNDED UP TO THE NEAREST WHOLE MILLIMETER  
SPECIFICATIONS SUBJECT TO CHANGE WITHOUT NOTICE



Model	Elevation	Right	Plan	3D	Back
TR1HRT-1S-1S	TFQY82E	TFQY82S	TFQY82P	TFQY843	

**TRUE FOOD SERVICE EQUIPMENT**