



TRUE FOOD SERVICE EQUIPMENT, INC.

2001 East Terra Lane • P.O. Box 970 • O'Fallon, Missouri 63366
 (636)240-2400 • Fax (636)272-2408 • (800)325-6152 • Intl Fax# (001)636-272-7546
 Parts Dept. (800)424-TRUE • Parts Dept. Fax# (636)272-9471 • www.truemfg.com

Project Name: _____

Location: _____

Item #: _____ Qty: _____

Model #: _____

A/A #

SIS #

Model:
TR2HPT-2G-2S

TR Spec Series:

Pass-Thru Glass Front/Solid Rear Swing Doors Heated Cabinet



TR2HPT-2G-2S

- ▶ Provides cabinet holding temperature of 80°F to 180°F (26.6°C to 82.2°C).
- ▶ Equipped with low-velocity fans to assure even temperature distribution throughout the cabinet. Fans are controlled by exterior on/off switch.
- ▶ Two (2) stainless steel (for corrosion resistance), finned tube heating elements (1000 watts each) per section for uniform generation of electric heat. Cabinet comes with a total of 4000 watts.
- ▶ 300 series stainless steel exterior and interior. The very finest stainless with higher tensile strength for fewer dents and scratches.
- ▶ Energy efficient, triple pane, thermal insulated glass front doors. 300 series stainless steel solid rear doors.
- ▶ Equipped with one (1) interior kit option per section, factory installed. Four (4) different interior kits available.
- ▶ Positive seal self-closing doors with 120° stay open feature. Lifetime guaranteed door hinges and torsion type closure system.
- ▶ Entire cabinet structure and solid rear doors are foamed-in-place using Ecomate. A new, innovative, high density, polyurethane insulation that has zero ozone depletion potential (ODP) and zero global warming potential (GWP).

ROUGH-IN DATA

Specifications subject to change without notice.
 Chart dimensions rounded up to the nearest 1/8" (millimeters rounded up to next whole number).

Model	Doors	Capacity (Cu. Ft.) (liters)	Cabinet Dimensions (inches) (mm)			Watts	Voltage	Cord Length (total ft.) (total m)	Crated Weight (lbs.) (kg)
			L	D†	H*				
TR2HPT-2G-2S	2 fr/ 2bk	56 1586	51 3/8 1305	37 1/4 947	78 1/4 1988	4000	115/208-230/60	9 2.74	N/A N/A

† Depth does not include 1 3/8" (35 mm) for door handles and system mechanical components.
 * Height does not include 6 1/8" (156 mm) for legs and 1" (26 mm) for system mechanical components.
 note: Requires hard wiring of 115/208-240/60 Hz, single phase, 3 pole, 4 wire circuit.



Printed in U.S.A.

APPROVALS:

AVAILABLE AT:

Model:
TR2HPT-2G-2S

TR Spec Series:

Pass-Thru Glass Front/Solid Rear Swing Doors Heated Cabinet



STANDARD FEATURES

DESIGN

- True's pass-thru heated cabinets are designed with enduring quality that protects your long term investment.

HEATER SYSTEM

- Cabinet is designed to provide holding temperatures of 80°F to 180°F (26.6°C to 82.2°C). Heating system controlled by exterior on/off switch and temperature control dial.
- Two (2) stainless steel (for corrosion resistance), finned tube heating elements (1000 watts each) per section for uniform generation of electric heat. Cabinet comes with a total of 4000 watts.
- Equipped with low-velocity fans to assure even temperature distribution throughout the cabinet. Fans are controlled by exterior on/off switch.
- Manually controlled vent located on top of the cabinet for positive humidity control.

CABINET CONSTRUCTION

- Exterior - 300 series stainless steel rear doors, front sides, back and bottom.
- Interior - 300 series stainless steel liner and floor.
- Insulation - entire cabinet structure and solid doors are foamed-in-place using Ecomate. A new, innovative, high density, polyurethane insulation that has zero ozone depletion potential (ODP) and zero global warming potential (GWP).
- Welded, heavy duty steel frame rail, black powder coated for corrosion protection.
- Frame rail fitted with 6" (153 mm) stainless steel legs.

DOORS

- Front doors are energy efficient, triple pane, thermal insulated glass.
- Rear doors are 300 series stainless steel exterior and liners.
- Doors open within cabinet dimension.
- Door locks standard.
- Each front glass door fitted with 15" (381 mm) long extruded aluminum handle.

- Each rear solid door fitted with 12" (305 mm) long, lifetime guaranteed, recessed handle that is foamed-in-place with a sheet metal interlock to ensure permanent attachment.
- Positive seal self-closing doors with 120° stay open feature. Lifetime guaranteed door hinges.
- Magnetic door gaskets of one piece construction, removable without tools for ease of cleaning.

SHELVING

- One (1) factory installed, interior kit option per section. Four (4) different interior kits available (see Kit Options). Pilasters and tray slides are factory installed at no charge.

LIGHTING

- Incandescent interior lighting; lights activated by exterior on/off switch, safety shielded.

MODEL FEATURES

- Exterior, color coded, temperature display; accurate direct reading of internal cabinet temperature.
- Designed to hold warm baked or cooked food. Cabinet is not designed to heat ambient or cold product.
- 12" x 20" (305 mm x 508 mm) pan for water included, if additional humidity is required.
- NSF-4 compliant for open food product.

ELECTRICAL

- True requires a sole use circuit be dedicated for the unit.
- Unit comes with 4 feed wires (including ground) to be hardwired at installation site to a 115/208-240/60 Hz. single phase, 20 amp dedicated outlet.

OPTIONAL FEATURES/ACCESSORIES

Upcharge and lead times may apply.

- ❑ 6" (153 mm) seismic/flanged legs.
- ❑ Stainless steel rail skirt (field installed).
- ❑ Metal solid door handle(s) (factory installed).
- ❑ Electronic temperature control (factory installed).
- ❑ Curb mountable units.

- ❑ Kit #1: Nine (9) sets of #1 type tray slides and pilasters (factory installed), bottom support of one (1) 18"L x 26"D (458 mm x 661 mm) pan or two (2) 14"L x 18"D (356 mm x 458 mm) pans.
- ❑ Kit #2: One (1) set half-section #2 steel rod tray slides and pilasters (factory installed), rim support of one (1) 18"L x 26"D (458 mm x 661 mm) pan.
- ❑ Kit #3: Six (6) sets of universal type tray slides and pilasters (factory installed), bottom support of one (1) 18"L x 26"D (458 mm x 661 mm) pan, two (2) 14"L x 18"D (356 mm x 458 mm) pans or two (2) 12"L x 20"D (305 mm x 508 mm) pans.
- ❑ Kit #4: Six (6) chrome shelves 23½"L x 27⅜"D (597 mm x 732 mm) with shelf clips and wall mounted pilasters (factory installed). Shelves adjustable on ½" (13 mm) increments.
- ❑ Additional kit option components available individually. Upcharge applies.
- ❑ Stainless steel (electro polished) shelves to be used with Kit Option #4.

PLAN VIEW

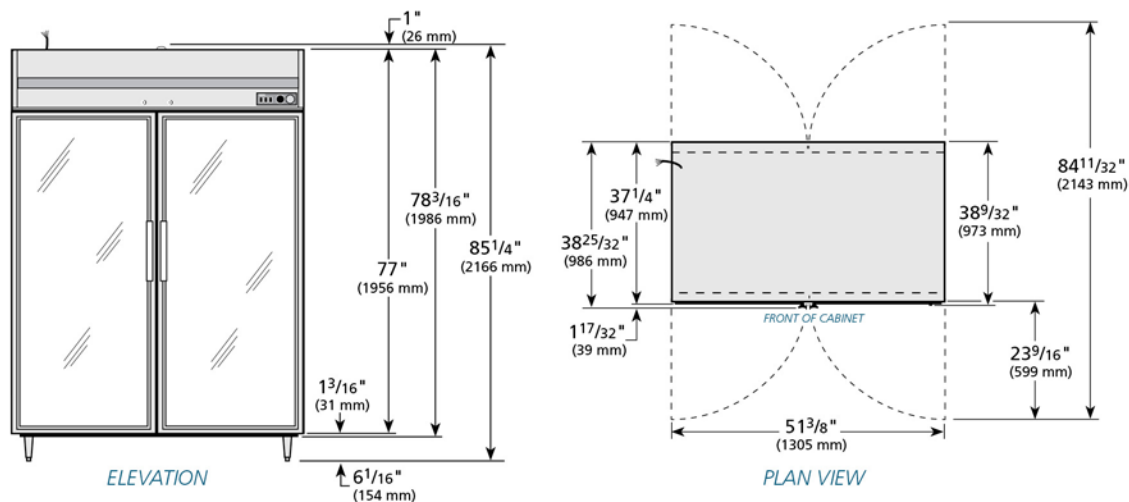

WARRANTY
One year warranty on all parts and labor. (U.S.A. only)

METRIC DIMENSIONS ROUNDED UP TO THE NEAREST WHOLE MILLIMETER
SPECIFICATIONS SUBJECT TO CHANGE WITHOUT NOTICE

KCL	Model	Elevation	Right	Plan	3D	Back
	TR2HPT-2G-2S	TFQX192E	TFQX192S	TFQX192P	TFQX1923	

TRUE FOOD SERVICE EQUIPMENT