



TRUE FOOD SERVICE EQUIPMENT, INC.

2001 East Terra Lane • P.O. Box 970 • O'Fallon, Missouri 63366
 (636)240-2400 • Fax (636)272-2408 • (800)325-6152 • Intl Fax# (001)636-272-7546
 Parts Dept. (800)424-TRUE • Parts Dept. Fax# (636)272-9471 • www.truemfg.com

Project Name: _____

Location: _____

Item #: _____ Qty: _____

Model #: _____

A/A #

SIS #

Model:

TG2RPT-4HS-2S

TG Spec Series:

Pass-Thru Solid Front Half Doors/Solid Rear Swing Doors Refrigerator



TG2RPT-4HS-2S

- ▶ Designed using the highest quality materials and components to provide the user with colder product temperatures, lower utility costs and exceptional food safety.
- ▶ Oversized, factory balanced, refrigeration system holds 33°F to 38°F (.5°C to 3.3°C) for the best in food preservation.
- ▶ 300 series stainless steel doors and front. Anodized quality aluminum exterior sides, back and bottom.
- ▶ NSF approved, white aluminum interior liner. 300 series stainless steel door liners and floor with coved corners.
- ▶ Adjustable, heavy duty PVC coated shelves.
- ▶ Positive seal self-closing doors with 120° stay open feature. Lifetime guaranteed door hinges.
- ▶ Lifetime guaranteed recessed door handles.
- ▶ Entire cabinet structure and solid doors are foamed-in-place using Ecomate. A new, innovative, high density, polyurethane insulation that has zero ozone depletion potential (ODP) and zero global warming potential (GWP).

ROUGH-IN DATA

Specifications subject to change without notice.
 Chart dimensions rounded up to the nearest 1/8" (millimeters rounded up to next whole number).

Model	Doors	Capacity (Cu. Ft.) (liters)	Shelves	Cabinet Dimensions (inches) (mm)			HP	Voltage	Amps	NEMA Config.	Cord Length (total ft.) (total m)	Crated Weight (lbs.) (kg)
				L	D	H*						
TG2RPT-4HS-2S	4 fr/2 bk	56 1586	6	51 3/8 1305	37 1/4 947	78 1/4 1988	3/4	115/60/1	15.5	5-20P	9 2.74	N/A N/A

* Height does not include 5" (127 mm) for castors and 1" (26 mm) for system mechanical components.



Printed in U.S.A.

APPROVALS:

AVAILABLE AT:

Model:
TG2RPT-4HS-2S

TG Spec Series:
Pass-Thru Solid Front Half Doors/Solid Rear Swing Doors
Refrigerator



STANDARD FEATURES

DESIGN

- True's solid half door pass-thru's are designed with enduring quality that protects your long term investment.
- Designed using the highest quality materials and components to provide the user with colder product temperatures, lower utility costs and exceptional food safety.

REFRIGERATION SYSTEM

- Factory engineered, self-contained, capillary tube system using environmentally friendly (CFC free) 134A refrigerant.
- Extra large evaporator coil balanced with higher horsepower compressor and large condenser maintains cabinet temperatures of 33°F to 38°F (.5°C to 3.3°C) for the best in food preservation.
- Sealed, cast iron, self-lubricating evaporator fan motor(s) and larger fan blades give True pass-thru's a more efficient low velocity, high volume airflow design. This unique design ensures faster temperature recovery and shorter run times in the busiest of foodservice environments.
- Top mounted refrigeration system with evaporator positioned out of food zone to maximize capacity.
- Hot gas condensate for energy efficiency.

CABINET CONSTRUCTION

- Exterior - 300 series stainless steel doors and rainshield. Anodized quality aluminum sides, back and bottom.
- Interior - NSF approved white aluminum liner. 300 series stainless steel floor with coved corners.
- Insulation - entire cabinet structure and solid doors are foamed-in-place using Ecomate. A new, innovative, high density, polyurethane insulation that has zero ozone depletion potential (ODP) and zero global warming potential (GWP).
- Welded, heavy duty galvanized frame rail dipped in rust inhibiting enamel paint for corrosion protection inside and out.
- Frame rail fitted with 4" (102 mm) diameter stem castors - locks provided on front set.

DOORS

- 300 series stainless steel exterior and liners to match cabinet interior. Doors open within cabinet dimensions.
- Door locks standard.
- Lifetime guaranteed recessed door handles. Each door fitted with 12" (305 mm) long recessed handle that is foamed-in-place with a sheet metal interlock to ensure permanent attachment.
- Positive seal self-closing doors with 120° stay open feature. Lifetime guaranteed door hinges.
- Magnetic door gaskets of one piece construction, removable without tools for ease of cleaning.

SHELVING

- Six (6) adjustable, heavy duty PVC coated wire shelves 23½" x 28⅜" (597 mm x 732 mm). Four (4) shelf supports included per shelf. Shelves adjustable on 6" (153 mm) increments.
- Four (4) different interior kits available (see Kit Options). Pilasters and tray slides require field installation.

LIGHTING

- Incandescent interior lighting - lights activated by rocker switch mounted above top doors, safety shielded.

MODEL FEATURES

- Exterior digital temperature display, available with either°F or°C.
- Evaporator epoxy coated to eliminate the potential of corrosion
- NSF-7 compliant for open food product.

ELECTRICAL

- Unit completely pre-wired at factory and ready for final connection to a 115/60/1 phase, 20 amp dedicated outlet. Cord and plug set included.



115/60/1
NEMA-5-20R

OPTIONAL FEATURES/ACCESSORIES

Upcharge and lead times may apply.

- 6" (153 mm) standard legs.
- 6" (153 mm) seismic/flanged legs.
- 6" (153 mm) stainless steel legs.
- Stainless steel rail skirt for use with legs (field installed).
- Metal door handles (factory installed).
- Additional shelves.
- Electronic temperature control (factory installed).
- Curb mountable units.
- Remote cabinets (condensing unit supplied by others; system comes standard with 404A expansion valve and requires R404A refrigerant). Consult factory technical service department for BTU information.

KIT OPTIONS

Upcharge applies. Lead time may apply.

- Kit #1: Nine (9) sets of #1 type tray slides and pilasters (field installed), bottom support of one (1) 18"L x 26"D (458 mm x 661 mm) pan or two (2) 14"L x 18"D (356 mm x 458 mm) pans.
- Kit #2: One (1) set half-section #2 steel rod tray slides and pilasters (field installed), rim support of one (1) 18"L x 26"D (458 mm x 661 mm) pan.
- Kit #3: Six (6) sets of universal type tray slides and pilasters (field installed), bottom support of one (1) 18"L x 26"D (458 mm x 661 mm) pan, two (2) 14"L x 18"D (356 mm x 458 mm) pans or two (2) 12"L x 20"D (305 mm x 508 mm) pans.
- Kit #4: Three (3) chrome shelves 23½"L x 28⅜"D (597 mm x 732 mm). Four (4) shelf supports included per shelf (field installed); adjustable on 6" (153 mm) increments. Optional wall mounted shelf support pilasters (field installed) with four (4) shelf clips per shelf available; adjustable on ½" (13 mm) increments (must order at time of cabinet order).
- Additional kit option components available individually.

PLAN VIEW

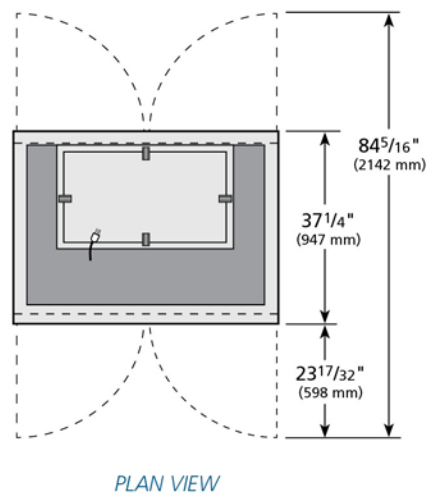
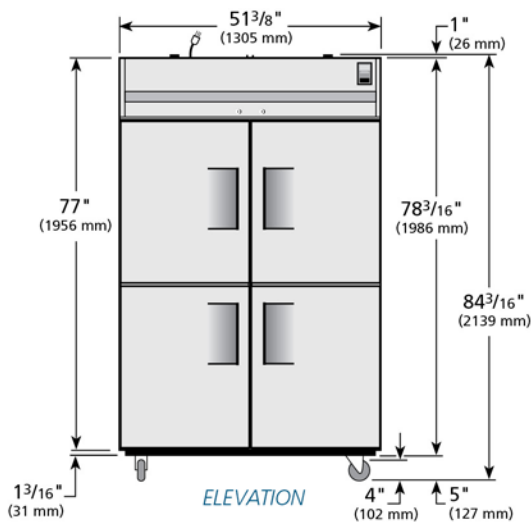

WARRANTY
One year warranty on all parts and labor and an additional 4 year warranty on compressor. (U.S.A. only)

METRIC DIMENSIONS ROUNDED UP TO THE NEAREST WHOLE MILLIMETER
SPECIFICATIONS SUBJECT TO CHANGE WITHOUT NOTICE



Model	Elevation	Right	Plan	3D	Back
TG2RPT-4HS-2S	TFQX59E	TFT017S	TFQY96P	TFT0173	

TRUE FOOD SERVICE EQUIPMENT