



**TRUE FOOD SERVICE  
EQUIPMENT, INC.**

2001 East Terra Lane • P.O. Box 970 • O'Fallon, Missouri 63366  
(636)240-2400 • Fax (636)272-2408 • (800)325-6152 • Intl Fax# (001)636-272-7546  
Parts Dept. (800)424-TRUE • Parts Dept. Fax# (636)272-9471 • www.truemfg.com

Project Name: \_\_\_\_\_

Location: \_\_\_\_\_

Item #: \_\_\_\_\_ Qty: \_\_\_\_\_

Model #: \_\_\_\_\_

A/A #

S/S #

Model:  
**TR1RPT-1S-1S**

**TR Spec Series:**

*Pass-Thru Solid Front/Solid Rear Swing Doors Refrigerator*



**TR1RPT-1S-1S**

- ▶ Designed using the highest quality materials and components to provide the user with colder product temperatures, lower utility costs and exceptional food safety.
- ▶ Oversized, factory balanced, refrigeration system holds 33°F to 38°F (.5°C to 3.3°C) for the best in food preservation.
- ▶ 300 series stainless steel exterior and interior. The very finest stainless with higher tensile strength for fewer dents and scratches.
- ▶ Equipped with (1) interior kit option, factory installed. Four (4) different interior kits available.
- ▶ Positive seal self-closing doors with 120° stay open feature. Lifetime guaranteed door hinges.
- ▶ Lifetime guaranteed recessed door handles.
- ▶ Entire cabinet structure and solid doors are foamed-in-place using Ecomate. A new, innovative, high density, polyurethane insulation that has zero ozone depletion potential (ODP) and zero global warming potential (GWP).

**ROUGH-IN DATA**

Specifications subject to change without notice.  
Chart dimensions rounded up to the nearest 1/8" (millimeters rounded up to next whole number).

Model	Doors	Capacity (Cu. Ft.) (liters)	Cabinet Dimensions (inches) (mm)			HP	Voltage	Amps	NEMA Config.	Cord Length (total ft.) (total m)	Crated Weight (lbs.) (kg)
			L	D	H*						
TR1RPT-1S-1S	1 fr / 1 bk	31 878	29 737	37 1/4 947	78 1/4 1988	1/2	115/60/1	10.4	5-15P	9 2.74	370 168

\* Height does not include 5" (127 mm) for castors and 1" (26 mm) for system mechanical components.



Printed in U.S.A.

**APPROVALS:**

**AVAILABLE AT:**

Model:  
**TR1RPT-1S-1S**

**TR Spec Series:**  
*Pass-Thru Solid Front/Solid Rear Swing Doors*  
**Refrigerator**



**STANDARD FEATURES**

**DESIGN**

- True's solid door pass-thru reach-in's are designed with enduring quality that protects your long term investment.
- Designed using the highest quality materials and components to provide the user with colder product temperatures, lower utility costs and exceptional food safety.

**REFRIGERATION SYSTEM**

- Factory engineered, self-contained, capillary tube system using environmentally friendly (CFC free) 134A refrigerant.
- Extra large evaporator coil balanced with higher horsepower compressor and large condenser maintains cabinet temperatures of 33°F to 38°F (.5°C to 3.3°C) for the best in food preservation.
- Sealed, cast iron, self-lubricating evaporator fan motor(s) and larger fan blades give True pass-thru's a more efficient low velocity, high volume airflow design. This unique design ensures faster temperature recovery and shorter run times in the busiest of foodservice environments.
- Top mounted refrigeration system with evaporator positioned out of food zone to maximize capacity.
- Hot gas condensate for energy efficiency.

**CABINET CONSTRUCTION**

- Exterior - 300 series stainless steel doors, front, sides, back and bottom.
- Interior - 300 series stainless steel liner and floor.
- Insulation - entire cabinet structure and solid doors are foamed-in-place using Ecomate. A new, innovative, high density, polyurethane insulation that has zero ozone depletion potential (ODP) and zero global warming potential (GWP).
- Welded, heavy duty steel frame rail, black powder coated for corrosion protection.
- Frame rail fitted with 4" (102 mm) diameter stem castors - locks provided on front set.

**DOORS**

- 300 series stainless steel exterior and liners. Doors open within cabinet dimension.
- Door locks standard.
- Lifetime guaranteed recessed door handles. Each door fitted with 12" (305 mm) long recessed handle that is foamed-in-place with a sheet metal interlock to ensure permanent attachment.
- Positive seal self-closing doors with 120° stay open feature. Lifetime guaranteed door hinges.
- Magnetic door gaskets of one piece construction, removable without tools for ease of cleaning.

**SHELVING**

- One (1) factory installed, interior kit option. Four (4) different interior kits available (see Kit Options). Pilasters and tray slides are factory installed at no charge.

**LIGHTING**

- Incandescent interior lighting - lights activated by rocker switch mounted above doors, safety shielded.

**MODEL FEATURES**

- Exterior digital temperature display, available with either °F or °C.
- Evaporator epoxy coated to eliminate the potential of corrosion
- NSF-7 compliant for open food product.

**ELECTRICAL**

- Unit completely pre-wired at factory and ready for final connection to a 115/60/1 phase, 15 amp dedicated outlet. Cord and plug set included.



115/60/1  
NEMA-5-15R

**OPTIONAL FEATURES/ACCESSORIES**

Upcharge and lead times may apply.

- 6" (153 mm) standard legs.
- 6" (153 mm) seismic/flanged legs.
- 6" (153 mm) stainless steel legs.

- Stainless steel rail skirt for use with legs (field installed).
- Metal door handle(s) (factory installed).
- Electronic temperature control (factory installed).
- Correctional facilities options.
- Curb mountable units.
- Remote cabinets (condensing unit supplied by others; system comes standard with 404A expansion valve and requires R404A refrigerant). Consult factory technical service department for BTU information. All remote units must be hard wired during installation.
- Kit #1: Nine (9) sets of #1 type tray slides and pilasters (factory installed), bottom support of one (1) 18" L x 26" D (458 mm x 661 mm) pan or two (2) 14" L x 18" D (356 mm x 458 mm) pans.
- Kit #2: One (1) set half-section #2 steel rod tray slides and pilasters (factory installed), rim support of one (1) 18" L x 26" D (458 mm x 661 mm) pan.
- Kit #3: Six (6) sets of universal type tray slides and pilasters (factory installed), bottom support of one (1) 18" L x 26" D (458 mm x 661 mm) pan, two (2) 14" L x 18" D (356 mm x 458 mm) pans or two (2) 12" L x 20" D (305 mm x 508 mm) pans.
- Kit #4: Three (3) chrome shelves 25" L x 27 3/4" D (635 mm x 705 mm). Four (4) shelf supports included per shelf (factory installed); adjustable on 6" (153 mm) increments. Optional wall mounted shelf support pilasters (factory installed) with four (4) shelf clips per shelf available; adjustable on 1/2" (13 mm) increments.
- Additional kit option components available individually. Upcharge applies.

**PLAN VIEW**

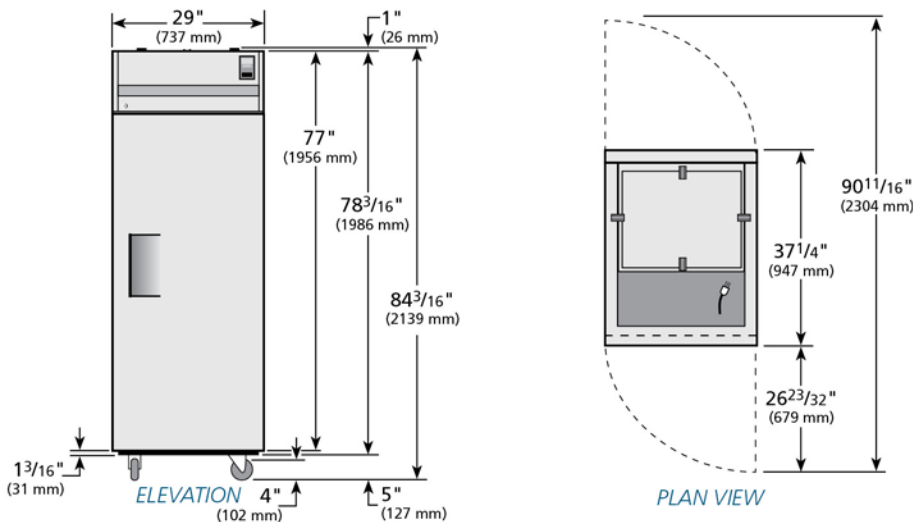

**WARRANTY**  
 One year warranty on all parts and labor and an additional 4 year warranty on compressor. (U.S.A. only)

METRIC DIMENSIONS ROUNDED UP TO THE NEAREST WHOLE MILLIMETER  
 SPECIFICATIONS SUBJECT TO CHANGE WITHOUT NOTICE



Model	Elevation	Right	Plan	3D	Back
TR1RPT-1S-1S	TFQY50E	TFQY89S	TFQY181P	TFQY893	

**TRUE FOOD SERVICE EQUIPMENT**