



Profit from the Eagle Advantage®

Specification Sheet

Short Form Specifications

Eagle 1800 Series Ice Chests, model _____.
 Top, front, backsplash, ice bin and sliding cover to be heavy gauge type 304 stainless steel. Fabricated ice bin is fully insulated with 1½" drain. 1½" O.D. galvanized tubular legs with adjustable bullet feet.



#B21C-18 ice chest

Options / Accessories

- Stainless steel leg kits (see below)
- Speed rails

| Optional Stainless Steel Leg Kits for Ice Chests | |
|--|--|
| add suffix # | description |
| -SL | stainless steel leg assemblies |
| -SLF | stainless steel leg assemblies & stainless steel feet |
| -SLG | stainless steel leg assemblies & stainless steel gussets |
| -SLGF | stainless steel leg assemblies, stainless steel feet & gussets |

Item No.: _____
 Project No.: _____
 S.I.S. No.: _____

1800 Series Ice Chests

MODELS:

- | | | |
|---------------------------------------|---------------------------------------|---------------------------------------|
| <input type="checkbox"/> B12IC-18 | <input type="checkbox"/> B21C-12D-18 | <input type="checkbox"/> B36IC-16D-18 |
| <input type="checkbox"/> B12IC-12D-18 | <input type="checkbox"/> B21C-16D-18 | <input type="checkbox"/> B42IC-18 |
| <input type="checkbox"/> B12IC-16D-18 | <input type="checkbox"/> B30IC-18 | <input type="checkbox"/> B42IC-12D-18 |
| <input type="checkbox"/> B18IC-18 | <input type="checkbox"/> B30IC-12D-18 | <input type="checkbox"/> B42IC-16D-18 |
| <input type="checkbox"/> B18IC-12D-18 | <input type="checkbox"/> B30IC-16D-18 | <input type="checkbox"/> B48IC-18 |
| <input type="checkbox"/> B18IC-16D-18 | <input type="checkbox"/> B36IC-18 | <input type="checkbox"/> B48IC-12D-18 |
| <input type="checkbox"/> B21C-18 | <input type="checkbox"/> B36IC-12D-18 | <input type="checkbox"/> B48IC-16D-18 |

Design and Construction Features

- Bullnose front edge.
- Stainless steel type 304 ice bin, backsplash, front, and sliding ice cover.
- Galvanized ends and back panel.
- 1½" (38mm) drain centered, and complete with fiberglass insulation.
- Ice bins are fabricated.
- High-impact, corrosion-resistant, fully-adjustable bullet feet.
- Standard models include 8", 12" and 16" (203, 305 and 406mm)-depth units.

EAGLE GROUP
 100 Industrial Boulevard, Clayton, DE 19938-8903 USA
 Phone: 302-653-3000 • Fax: 302-653-2065
 www.eaglegrp.com

Foodservice Division: Phone 800-441-8440
MHC/Retail Display Divisions: Phone 800-637-5100

For custom configuration or fabrication needs, contact our **SpecFAB® Division**.
 Phone: 302-653-3000 • Fax: 302-653-2065 • e-mail: quotes@eaglegrp.com



EG40.04A Rev. 07/18

Spec sheets available for viewing, printing or downloading from our online literature library at www.eaglegrp.com

Eagle Foodservice Equipment, Eagle MHC, SpecFAB®, and Retail Display are divisions of Eagle Group. ©2018 by the Eagle Group



Item No.: _____
 Project No.: _____
 S.I.S. No.: _____

1800 Series Ice Chests

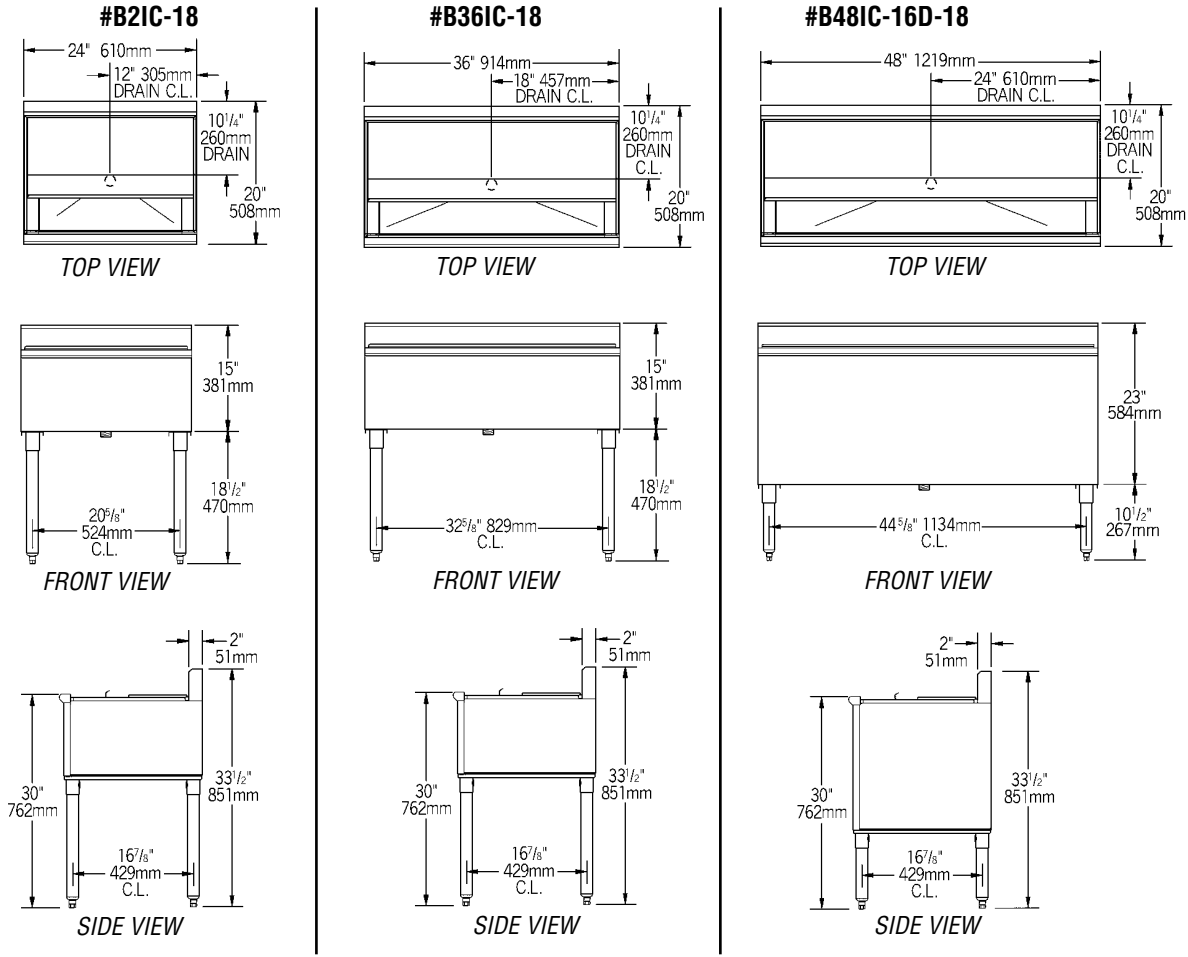

| model # | width x length | | weight | | ice bin depth | | ice capacity | |
|---------------------|----------------|------------|--------|------|---------------|-----|--------------|------|
| | in. | mm | lbs. | kg | in. | mm | lbs. | kg |
| B12IC-18 | 20" x 12" | 495 x 305 | 42 | 19.1 | 8" | 203 | 14 | 6.4 |
| B12IC-12D-18 | 20" x 12" | 495 x 305 | 44 | 20.0 | 12" | 305 | 22 | 10.0 |
| B12IC-16D-18 | 20" x 12" | 495 x 305 | 46 | 20.9 | 16" | 406 | 29 | 13.2 |
| B18IC-18 | 20" x 18" | 495 x 457 | 48 | 21.8 | 8" | 203 | 25 | 11.3 |
| B18IC-12D-18 | 20" x 18" | 495 x 457 | 52 | 23.6 | 12" | 305 | 38 | 17.2 |
| B18IC-16D-18 | 20" x 18" | 495 x 457 | 58 | 26.3 | 16" | 406 | 51 | 23.1 |
| B21C-18 | 20" x 24" | 495 x 610 | 52 | 23.6 | 8" | 203 | 37 | 16.8 |
| B21C-12D-18 | 20" x 24" | 495 x 610 | 61 | 27.7 | 12" | 305 | 55 | 24.9 |
| B21C-16D-18 | 20" x 24" | 495 x 610 | 66 | 29.9 | 16" | 406 | 73 | 33.1 |
| B30IC-18 | 20" x 30" | 495 x 762 | 60 | 27.2 | 8" | 203 | 48 | 21.8 |
| B30IC-12D-18 | 20" x 30" | 495 x 762 | 74 | 33.6 | 12" | 305 | 71 | 32.2 |
| B30IC-16D-18 | 20" x 30" | 495 x 762 | 87 | 39.5 | 16" | 406 | 95 | 43.1 |
| B36IC-18 | 20" x 36" | 495 x 914 | 74 | 33.6 | 8" | 203 | 59 | 26.8 |
| B36IC-12D-18 | 20" x 36" | 495 x 914 | 95 | 43.1 | 12" | 305 | 88 | 39.9 |
| B36IC-16D-18 | 20" x 36" | 495 x 914 | 101 | 45.8 | 16" | 406 | 117 | 53.1 |
| B42IC-18 | 20" x 42" | 495 x 1067 | 71 | 32.7 | 8" | 203 | 70 | 31.8 |
| B42IC-12D-18 | 20" x 42" | 495 x 1067 | 98 | 44.5 | 12" | 305 | 105 | 47.6 |
| B42IC-16D-18 | 20" x 42" | 495 x 1067 | 104 | 47.2 | 16" | 406 | 140 | 63.5 |
| B48IC-18 | 20" x 48" | 495 x 1219 | 82 | 37.2 | 8" | 203 | 81 | 36.7 |
| B48IC-12D-18 | 20" x 48" | 495 x 1219 | 101 | 45.8 | 12" | 305 | 121 | 54.9 |
| B48IC-16D-18 | 20" x 48" | 495 x 1219 | 113 | 51.3 | 16" | 406 | 162 | 73.5 |

EAGLE GROUP
 100 Industrial Boulevard, Clayton, DE 19938-8903 USA
 Phone: 302-653-3000 • Fax: 302-653-2065
 www.eaglegrp.com

Foodservice Division: Phone 800-441-8440
 MHC/Retail Display Divisions: Phone 800-637-5100

Printed in U.S.A.
 ©2018 by Eagle Group
 Rev. 07/18

Spec sheets available for viewing, printing or downloading from our online literature library at www.eaglegrp.com

Although every attempt has been made to ensure the accuracy of the information provided, we cannot be held responsible for typographical or printing errors. Information and specifications are subject to change without notice. Please confirm at time of order.