



WELLS MANUFACTURING
 10 Sunnen Dr., St. Louis, MO 63143
 telephone: 314-678-6314
 fax: 314-781-2714
 www.wellsbloomfield.com

OWNERS MANUAL
 for
**COUNTER TOP
 ELECTRIC
 HOTPLATES**

Models:

H33

H63

H65

H70

H115



Model H70

Includes
INSTALLATION
USE & CARE
EXPLODED VIEW
PARTS LIST
WIRING DIAGRAM

IMPORTANT: DO NOT DISCARD THIS MANUAL

This manual is considered to be part of the appliance and is to be given to the OWNER or MANAGER of the restaurant, or to the person responsible for TRAINING OPERATORS of this appliance. Additional manuals are available from your WELLS DEALER.

THIS MANUAL MUST BE READ AND UNDERSTOOD BY ALL PERSONS USING OR INSTALLING THIS APPLIANCE. Contact your WELLS DEALER if you have any questions concerning installation, operation or maintenance of this equipment.

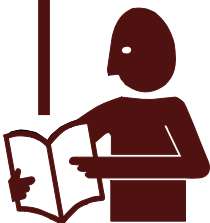

LIMITED WARRANTY STATEMENT

Unless otherwise specified, all commercial cooking equipment manufactured by WELLS MANUFACTURING is warranted against defects in materials and workmanship for a period of one year from the date of original installation or 18 months from the date of shipment from our factory, whichever comes first, and is for the benefit of the original purchaser only.

THIS WARRANTY IS THE COMPLETE AND ONLY WARRANTY, EXPRESSED OR IMPLIED IN LAW OR IN FACT, INCLUDING BUT NOT LIMITED TO, WARRANTIES OF MERCHANTABILITY OR FITNESS FOR ANY PARTICULAR PURPOSE, AND/OR FOR DIRECT, INDIRECT OR CONSEQUENTIAL DAMAGES IN CONNECTION WITH WELLS MANUFACTURING PRODUCTS. This warranty is void if it is determined that, upon inspection by an authorized service agency, the equipment has been modified, misused, misapplied, improperly installed, or damaged in transit or by fire, flood or act of God. It also does not apply if the serial nameplate has been removed, or if service is performed by unauthorized personnel. The prices charged

by Wells Manufacturing for its products are based upon the limitations in this warranty. Seller's obligation under this warranty is limited to the repair of defects without charge by a Wells Manufacturing factory authorized service agency or one of its sub-service agencies. This service will be provided on customer's premises for non-portable models. Portable models (a device with a cord and plug) must be taken or shipped to the closest authorized service agency, transportation charges prepaid, for service. In addition to restrictions contained in this warranty, specific limitations are shown in the Service Policy and Procedure Guide. Wells Manufacturing authorized service agencies are located in principal cities. This warranty is valid in the United States and Canada and void elsewhere. Please consult your classified telephone directory, your foodservice equipment dealer or contact:

Wells Manufacturing
10 Sunnen Dr., St. Louis MO 63143 USA
phone (314) 678-6314 or fax (314) 781-2714

for information and other details concerning warranty.

SERVICE POLICY AND PROCEDURE GUIDE and ADDITIONAL WARRANTY EXCLUSIONS

1. Resetting of safety thermostats, circuit breakers, over load protectors, and/or fuse replacements are not covered by this warranty unless warranted conditions are the cause.
2. All problems due to operation at voltages or phase other than specified on equipment nameplates are not covered by this warranty. Conversion to correct voltage and/or phase must be the customer's responsibility.
3. All problems due to electrical connections not made in accordance with electrical code requirements and wiring diagrams supplied with the equipment are not covered by this warranty.
4. Replacement of items subject to normal wear, to include such items as knobs, light bulbs; and, normal maintenance functions including adjustments of thermostats, adjustment of micro switches and replacement of fuses and indicating lights are not covered by warranty.
5. Damage to electrical cords and/or plug due to exposure to excessive heat are not covered by this warranty.
6. Full use, care, and maintenance instructions supplied with each machine. Noted maintenance and preventative maintenance items, such as servicing and cleaning schedules, are customer responsibility.
7. Those miscellaneous adjustments noted are customer responsibility. Proper attention to preventative maintenance and scheduled maintenance procedures will prolong the life of the appliance.
8. Travel mileage is limited to sixty (60) miles from an Authorized Service Agency or one of its sub-service agencies.
9. All labor shall be performed during regular working hours. Overtime premium will be charged to the buyer.
10. All genuine Wells replacement parts are warranted for ninety (90) days from date of purchase on non-warranty equipment. This parts warranty is limited only to replacement of the defective part(s). Any use of non-genuine Wells parts completely voids any warranty.
11. Installation, labor, and job check-outs are not considered warranty and are thus not covered by this warranty.
12. Charges incurred by delays, waiting time or operating restrictions that hinder the service technician's ability to perform service are not covered by warranty. This includes institutional and correctional facilities.

SHIPPING DAMAGE CLAIM PROCEDURE

NOTE: For your protection, please note that equipment in this shipment was carefully inspected and packaged by skilled personnel before leaving the factory. Upon acceptance of this shipment, the transportation company assumes full responsibility for its safe delivery.

IF SHIPMENT ARRIVES DAMAGED:

1. **VISIBLE LOSS OR DAMAGE:** Be certain that any visible loss or damage is noted on the freight bill or express receipt, and that the note of loss or damage is signed by the delivery person.
2. **FILE CLAIM FOR DAMAGE IMMEDIATELY:**

Regardless of the extent of the damage.

3. **CONCEALED LOSS OR DAMAGE:** if damage is unnoticed until the merchandise is unpacked, notify the transportation company or carrier immediately, and file "CONCEALED DAMAGE" claim with them. This should be done within fifteen (15) days from the date the delivery was made to you. Be sure to retain the container for inspection.

Wells Bloomfield cannot assume liability for damage or loss incurred in transit. We will, however, at your request, supply you with the necessary documents to support your claim.

TABLE OF CONTENTS

WARRANTY	xi
SPECIFICATIONS	1
FEATURES & OPERATING CONTROLS	2
PRECAUTIONS & GENERAL INFORMATIOS	3
AGENCY APPROVAL INFORMATION	3
INSTALLATION	4
OPERATION	5
CLEANING INSTRUCTIONS	6
TROUBLESHOOTING	7
EXPLODED VIEW & PARTS LIST	8 - 17
WIRING DIAGRAMS	18 - 19
PARTS & SERVICE	21
CUSTOMER SERVICE DATA	

INTRODUCTION

Thank You for purchasing this Wells Manufacturing appliance.

Proper installation, professional operation and consistent maintenance of this equipment will ensure that it gives you the very best performance and a long, economical service life.

This manual contains the information needed to properly install this equipment, and to use and care for the equipment in a manner which will ensure its optimum performance.

SPECIFICATIONS

MODEL	ELEMENT	WIDTH	DEPTH	VOLTS	AMPS	kW	PLUG	LEG HEIGHT
H33	Single 6" Coil	12-5/8"	12-5/8"	120 V 1ø	12.5 A	1.5 kW	NEMA 5-15P	4"
H63	Dual 8" Coils	14-3/4"	23-1/2"	208 V 1ø	18.8 A	3.9 kW	NEMA 6-30P	
				240 V 1ø	21.7 A	5.2 kW	NEMA 6-30P	
H65	Dual 8" Coils	13"	29-9/16"	208 V 1ø	18.8 A	3.9 kW	None	
				240 V 1ø	21.7 A	5.2 kW	None	
H70	Dual 9" french plates	14-3/4"	23-1/2"	208 V 1ø	14.4 A	3.0 kW	None	
				240 V 1ø	16.7 A	4.0 kW	None	
H115	Dual 6" Coils	14-3/4"	23-9/16"	120 V 1ø	13.8 A	1.7 kW	NEMA 5-15P	1"

FEATURES & OPERATING CONTROLS

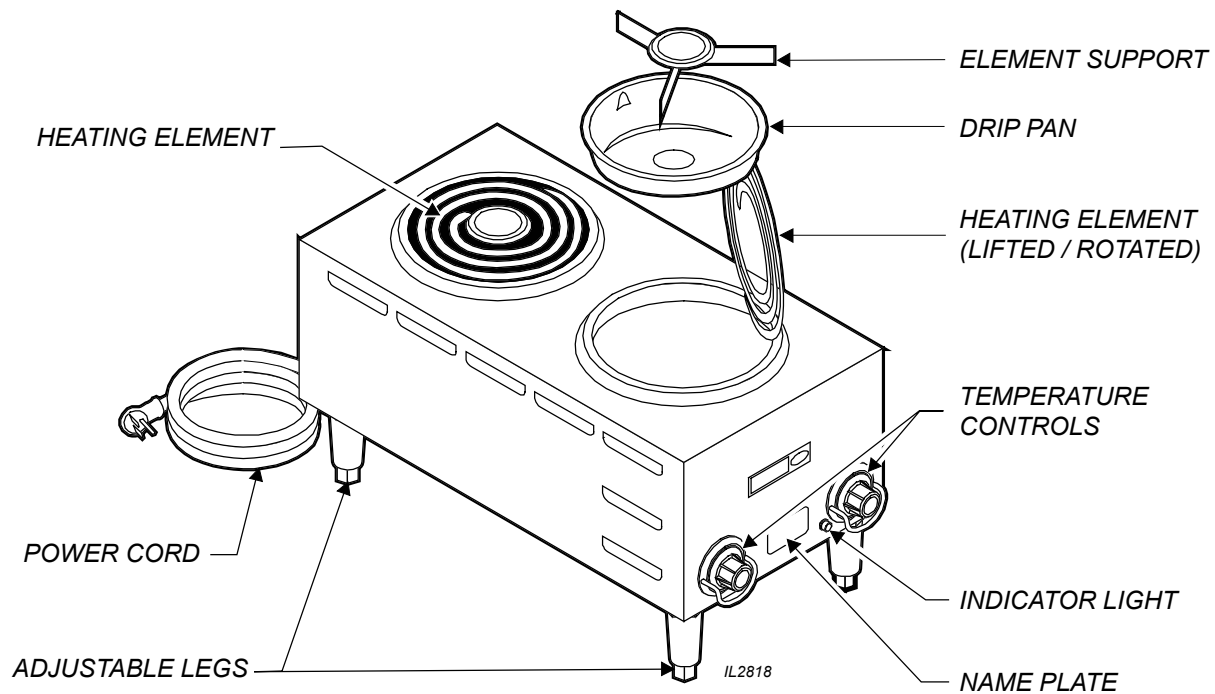

	Provides heat for food preparation
Heating Element	Coil-type elements rotate for access to drip pan <i>Note: Solid (french plate) elements on model H-70 do not lift</i>
Element Support*	Holds coil-type element in proper position
Drip Pan*	Collects drippings and holds element support Also deflects heat from element for more efficient cooking
Temperature Control	Infinite switch to control temperature of heating element
Indicator Light	Glows any time temperature control is on
Name Plate	Lists manufacturer, model number and serial number Also lists voltage and wattage rating
Power Cord (when provided)	Connects hotplate to electrical power Some units require wiring directly into electrical circuit
Adjustable Legs	Provide ventilation under hotplate Allow hotplate to be leveled

* not used on model H70

PRECAUTIONS AND GENERAL INFORMATION

This appliance is intended for use in commercial establishments only.

This appliance is intended to prepare food for human consumption. No other use is recommended or authorized by the manufacturer or its agents.

Operators of this appliance must be familiar with the appliance use, limitations and associated restrictions. Operating instructions must be read and understood by all persons using or installing this appliance.

Cleanliness of this appliance is essential to good sanitation. Read and follow all included cleaning instructions and schedules to ensure the safety of the food product.

Hotplates with coil-type heating elements must be operated with drip pan and element support properly installed.

Disconnect the hotplate from electrical power before performing any maintenance or servicing.

DO NOT submerge hotplate in water. DO NOT splash or pour water over, onto or into controls, control panel or wiring.

The technical content of this manual, including any wiring diagrams, schematics, parts breakdown illustrations and/or adjustment procedures, is intended for use by qualified technical personnel.

Any procedure which requires the use of tools must be performed by a qualified technician.

This manual is considered to be a permanent part of the appliance. This manual and all supplied instructions, diagrams, schematics, parts breakdown illustrations, notices and labels must remain with the appliance if it is sold or moved to another location.

This appliance is made in the USA. Unless otherwise noted, this appliance has American sizes on all hardware.



WARNING: ELECTRIC SHOCK HAZARD

All servicing requiring access to non-insulated electrical components must be performed by a factory authorized technician.

DO NOT open any access panel that requires the use of tools. Failure to follow this warning can result in severe electrical shock.



CAUTION: RISK OF DAMAGE

DO NOT connect and/or energize this appliance until all installation instructions are read and followed. Damage to the appliance will result if these instructions are not followed.

AGENCY APPROVAL INFORMATION

This appliance complies with NSF Standard 4 only when maintained and operated per the instructions in this manual.

This appliance is UL listed under E6070.



STD 4



E6070

INSTALLATION

NOTE: DO NOT discard the carton or other packing materials until you have inspected the appliance for hidden damage and tested it for proper operation. Refer to *SHIPPING DAMAGE CLAIM PROCEDURE* on the inside front cover of this manual.



CAUTION: ELECTRIC SHOCK HAZARD

The ground prong of the power cord is part of a system designed to protect you from electric shock in the event of internal damage to the appliance. NEVER CUT OFF THE GROUND PRONG (large round prong). NEVER TWIST A PRONG TO FIT AN EXISTING RECEPTACLE. Contact a licensed electrician to install an electrical receptacle appropriate to the voltage and amperage requirements of the hotplate.

IMPORTANT:

Damage due to being plugged into the wrong voltage or phase is NOT covered by Warranty.

UNPACKING & INSPECTION

Carefully remove the hotplate from the carton. Remove all protective plastic film, packing materials and accessories from the hotplate before plugging the hotplate into electrical power or otherwise performing any installation procedure.

Carefully read all instructions in this manual and the Installation Instruction Sheet packed with the hotplate before starting any installation.

Read and understand all labels and diagrams attached to the hotplate.

Carefully account for all components and accessories before discarding packing materials. Store all accessories in a convenient place for later use.

SETUP

Supplied legs must be properly installed.

Setup the hotplate only on a firm level surface. Non-combustible material (e.g. metal, terrazzo) is recommended.

Maintain at least 1" from adjacent surfaces.

ELECTRICAL

Refer to the nameplate. Verify the electrical service power. Voltage and phase must match the nameplate specifications. Connecting the hotplate to the wrong voltage can severely damage the equipment or cause noticeably decreased performance.

If your hotplate is equipped with a grounded electric power cord, this cord must be plugged into a properly grounded electrical receptacle.

If your hotplate is not supplied with a cordset, the hotplate must be installed by a licensed electrician in accordance with all applicable codes and ordinances.

GENERAL OPERATIONAL NOTES

Carefully read the description of the hotplate operation on the specification sheet.

DO NOT attempt to perform any maintenance or service unless the hotplate is disconnected from electrical power.

DO turn the circuit breaker for the hotplate off before cleaning, servicing or performing any maintenance.

DO NOT use sharp objects or metal implements to clean the heating elements.

DO use a plastic spatula or plastic scouring pad to remove burned-on food product.

OPERATION

Each heating element is controlled by an infinite switch temperature control:

OFF removes power from the element

LOW thru 8 are temperature settings

Higher numbers indicate higher temperatures

There is a continuous range of settings between LOW and HI

HI is a continuous ON setting

The indicator light will glow any time the temperature control is on.

Cooking Recommendations:

Save energy by turning the temperature control off any time the hotplate is not in use. The coil-type heating elements will provide full heat within 30 seconds, while french plate heating elements will reach full heat within 2 minutes, making it unnecessary to leave the unit on during intermittent use.

Each heating element can hold up to a 16 quart pot or pan. For efficient heating of food product, pots and pans should be no more than 10" in diameter.

Maximize the efficiency of solid (french plate) elements by using flat-bottom pots and pans.

Stir thick liquids frequently to maintain a consistent temperature.



CAUTION: HOT SURFACE

Exposed surfaces can be hot to the touch and may cause burns.

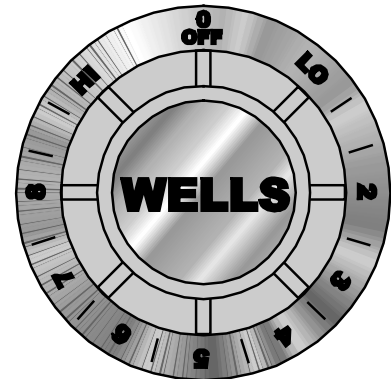

Temperature Control Knob

IMPORTANT:

The dial markings are an INDICATION of temperature only. The temperature of the food product depends on many factors, including the size, shape and material of the food container, and the quantity and consistency of the food product.

CLEANING INSTRUCTIONS



CAUTION: ELECTRIC SHOCK HAZARD

Disconnect hotplate from electric power before cleaning.



CAUTION: BURN HAZARD

Allow hotplate element and cabinet to cool completely before cleaning.



CAUTION: ELECTRIC SHOCK HAZARD

Do not submerge hotplate in water.

IMPORTANT: DO NOT spill or pour water into interior of hotplate.

IMPORTANT: DO NOT spill or pour water into controls, control panel or wiring.

DO NOT submerge hotplate in water. Damage to internal components will occur.

Damage to internal components from water damage is NOT covered by warranty.

DO NOT use metal implements, steel wool or metal scouring pads to clean heating elements.

PREPARATION

Unplug or disconnect hotplate from electrical power before cleaning. Allow hotplate to cool completely before cleaning.

FREQUENCY

Daily

TOOLS

Plastic Spatula and Plastic Scouring Pad

Clean Cloth or Sponge

Mild Detergent or Cleaner Formulated for Stainless Steel

Warm Water

CLEANING

Unplug or disconnect hotplate from electrical power and allow heating element to cool completely before cleaning.

COILED HEATING ELEMENTS:

Lift coiled heating elements and remove drip pans. Clean drip pans with a plastic spatula or plastic scouring pad, mild detergent and warm water. DO NOT use metal implements, steel wool or metal scouring pads to clean drip pans. Rinse drip pans by wiping with a clean cloth or sponge dampened with clean water.

Clean heating elements with a plastic spatula or plastic scouring pad, mild detergent and warm water. DO NOT use metal implements, steel wool or metal scouring pads to clean elements. Rinse by wiping with a clean cloth or sponge dampened with clean water.

Reinstall drip pans and gently lower heating element.

FRENCH PLATE HEATING ELEMENTS:

French plate elements do not lift. Clean heating elements with a plastic spatula or plastic scouring pad, mild detergent and warm water. DO NOT use metal implements, steel wool or metal scouring pads to clean elements. Rinse by wiping with a clean cloth or sponge dampened with clean water.

CABINET:

Wipe the outer portions of the hotplate cabinet with a clean soft cloth or sponge dampened with warm water and a mild detergent or cleaner formulated for cleaning stainless steel. DO NOT use steel wool to clean hotplate cabinet.

Rinse by wiping hotplate cabinet with a clean soft cloth or sponge moistened with clean warm water.

Dry cabinet and elements by wiping with a clean soft dry cloth.

TROUBLESHOOTING

SYMPTOM	POSSIBLE CAUSE	SUGGESTED REMEDY
Hotplate won't heat	Not plugged in, damaged plug or cord or circuit breaker tripped	Check plug and cord
		Check / reset circuit breaker
One or more sections won't heat	Temperature control not on	Turn temperature control to desired setting
	Damaged temperature control, element or other internal component	Contact Authorized Wells Service Agency for repairs
Hotplate not hot enough	Temperature control not set	Adjust for desired temperature
	Operating 208/240V unit at 120V	Be sure supply voltage matches nameplate voltage
	Damaged temperature control, element or other internal component	Contact Authorized Wells Service Agency for repairs

NOTE: There are no user serviceable components in this appliance. In all cases of damage or component malfunction, contact your Authorized Wells Service Agency for repairs.

EXPLODED VIEW: H33

H-33 COUNTERTOP ELECTRIC HOTPLATE - 115V - SPIRAL ELEMENT

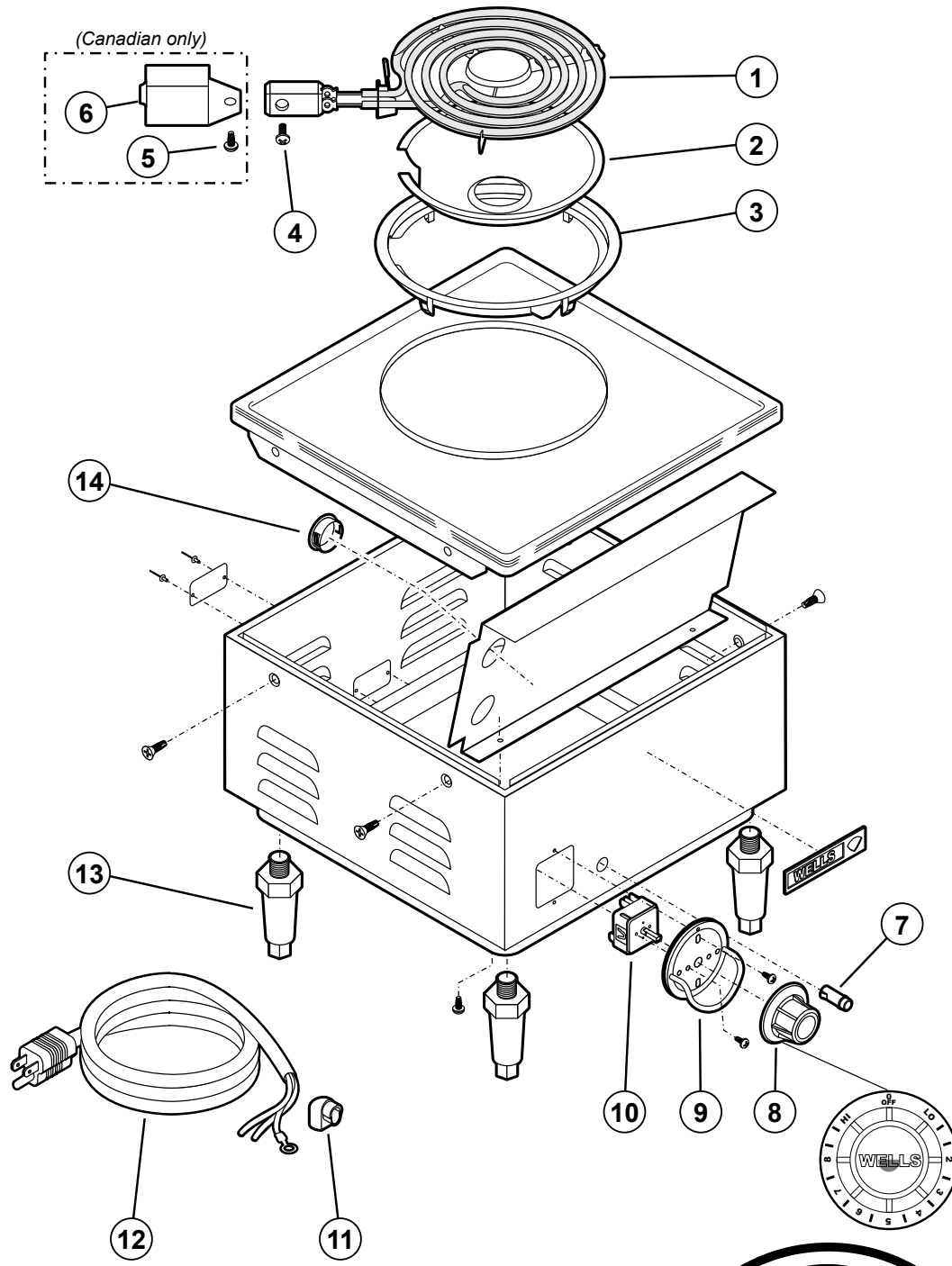

Model: H33
Countertop Electric Hotplate - 115V - Spiral Element
PL221

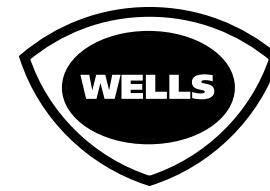

IL1747 Rev. A 4/24/09

221 p/n 2M-303733 Owners Manual CT Hotplate

H33 COUNTERTOP ELECTRIC HOTPLATE			
Fig No	Part No	Qty	Description
1	2N-30514ELUL	1	ELEMENT 120V 1500WW H33
2	2D-30514DT	1	DRIP TRAY H115 & H33
3	I7-30514CR	1	ASSY CLIPS & RING H115 & H33
4	2C-33977	AR	SCREW 8-32X3/8 PH BND HD
5	2C-300243	AR	SCREW 10-32X1/4 PH BND HD
6	I7-43370	1	COVER TERM H33 115 CSA
7	2J-30516	1	LIGHT SIGNAL AMBER
8	2R-30371	1	KNOB ASSY WARMERS
9	D8-30256	1	TRIM RING ASSY
10	2E-30570	1	SWITCH INFINITE 120V
11	2K-31217	1	STRAIN RELIEF 90DEG
12	2E-35539	1	CORD SET 120V 15A 16GA 4FT
13	2R-Y5092	4	FEET ADJ 4GRAY 3/8-16 PK
14	2K-31040	1	BUSHING 7/8 OD

EXPLODED VIEW: H63

H-63 COUNTERTOP ELECTRIC HOTPLATE - 208/240V - SPIRAL ELEMENT

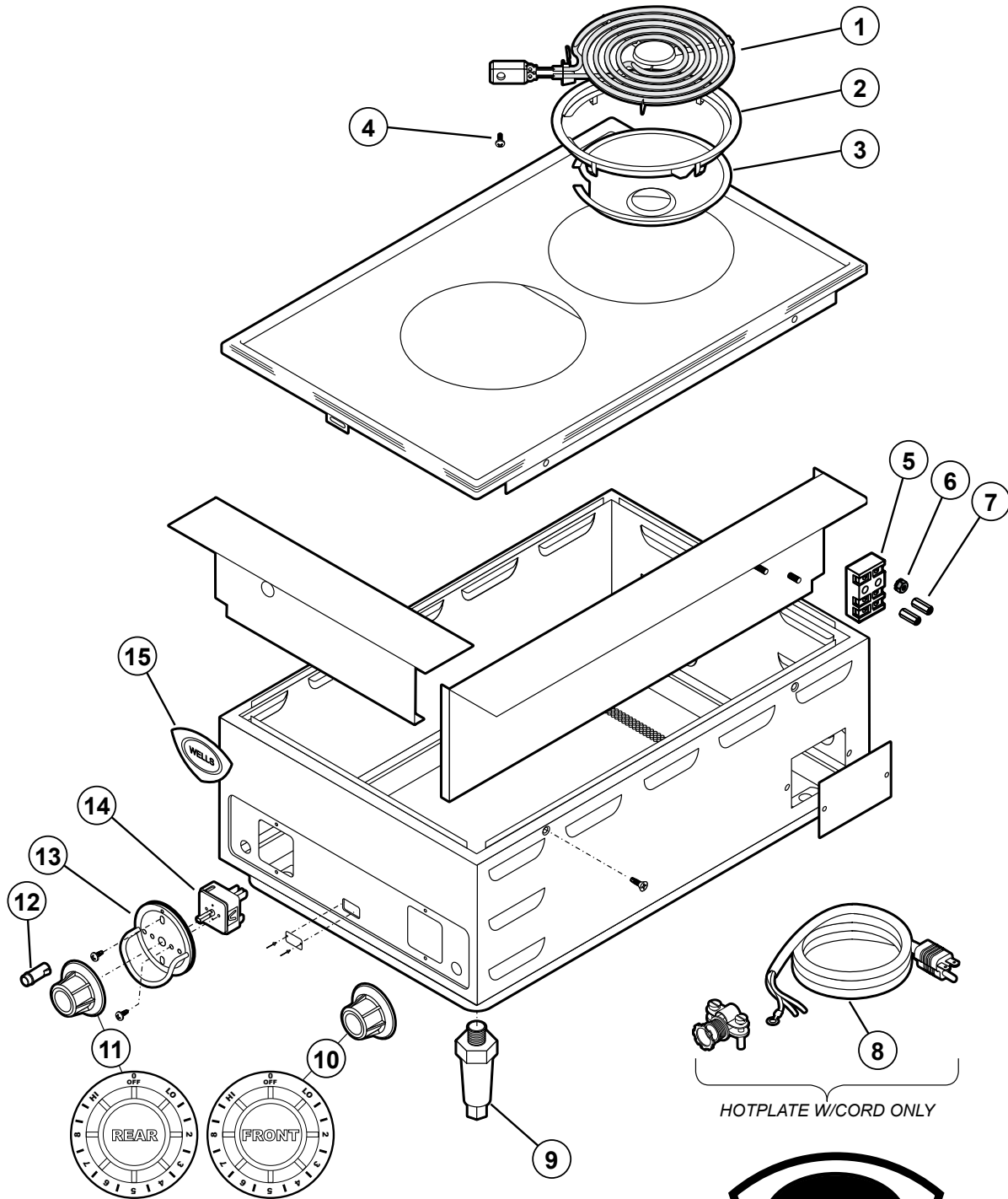

Model: H63
Countertop Electric Hotplate - 208/240V - Spiral Element

PL221



IL1748 Rev. B 1/18/10

221 p/n 2M-303733 Owners Manual CT Hotplate

H63 COUNTERTOP ELECTRIC HOTPLATE			
Fig No	Part No	Qty	Description
1	2N-30293ELUL	2	ELEMENT 240V 260W H63
2	I7-30293CR	2	ASSY CLIPS & TRIM RING H-
3	2D-30293DT	2	DRIP TRAY H-63
4	2C-33977	2	SCREW 8-32X3/8 PH BND HD
5	WS-50131	1	TERM BLOCK KIT (RETRO 301)
6	2C-35736	2	NUT 8-32 HEX KEPS MS GREEN
7	2C-41974	2	NUT 8-32 HEX 7/8 LONG ALU
8	2E-35259	1	CORD SET 250V 30A 12G 6-30P
9	2A-30586	4	FEET ADJ 4GRAY 3/8-16
10	2R-30583	1	KNOB ASSY FRONT HOTPLATE
11	2R-30584	1	KNOB RR HP91
12	2J-30516	2	LIGHT SIGNAL AMBER
13	D8-30256	2	TRIM RING ASSY
14	2E-30562	2	SWITCH INFINITE 240V
15	2M-300534	1	TRADEMARK DOMED LABEL WARMER

EXPLODED VIEW: H65

H-65 COUNTERTOP ELECTRIC HOTPLATE - 208/240V - SPIRAL ELEMENT

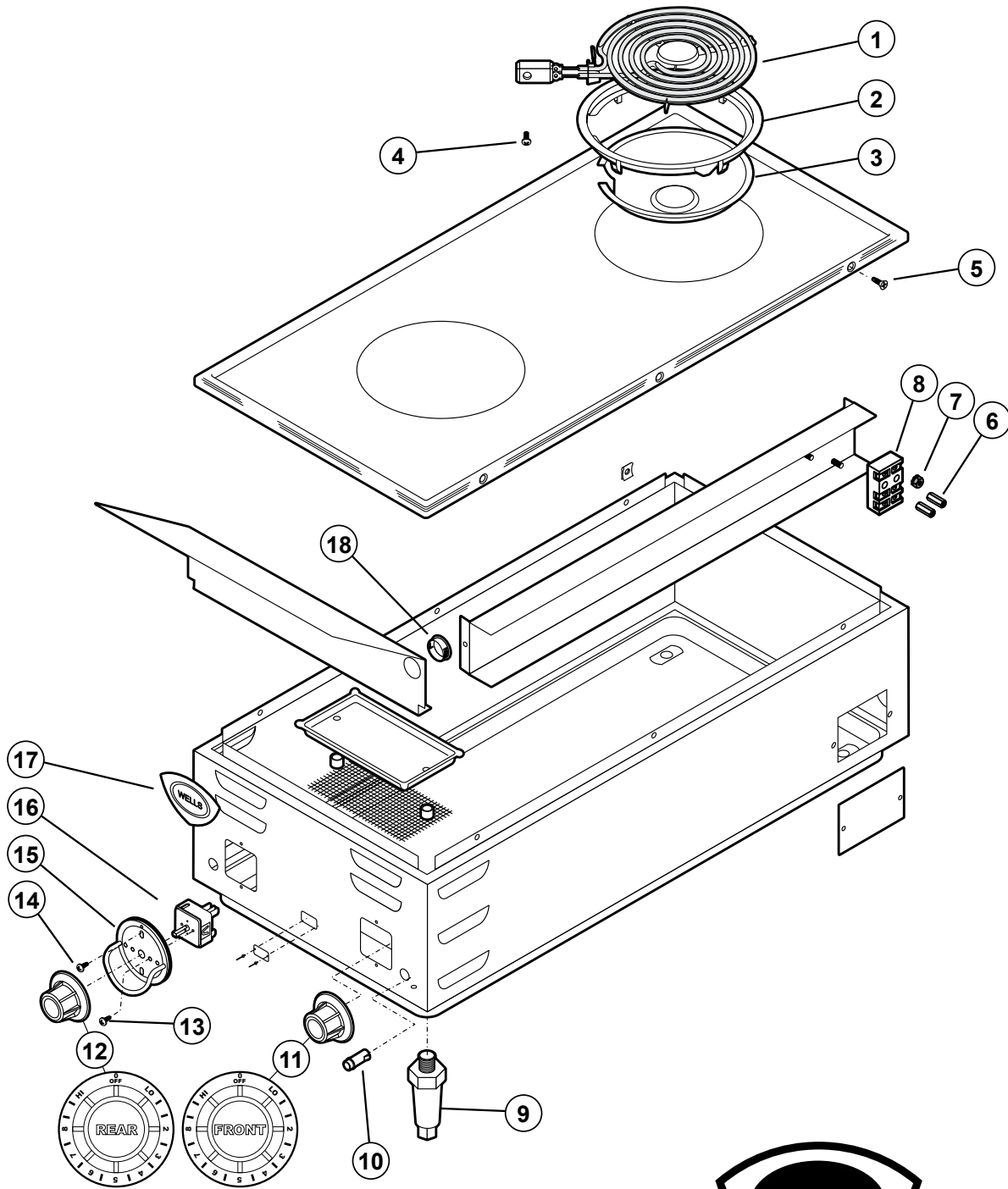

Model: H65
Countertop Electric Hotplate - 208/240V - Spiral Element
PL221



IL1749 Rev. A 4/24/09

221 p/n 2M-303733 Owners Manual CT Hotplate

H65 COUNTERTOP ELECTRIC HOTPLATE 208/240V			
Fig No	Part No	Qty	Description
1	2N-30293ELUL	2	ELEMENT 240V 2600W
2	I7-30293CR	2	ASSY CLIPS & TRIM RING
3	2D-30293DT	2	DRIP TRAY
4	2C-33977	2	SCREW 8-32X3/8 PH BND HD
5	2C-54285	AR	SCREW 8-32X3/8 PH 100 FL
6	2C-41974	2	NUT 8-32 HEX 7/8 LONG ALU
7	2C-35736	AR	NUT 8-32 HEX KEPS MS GREEN
8	WS-50131	1	TERM BLK KIT - 3POLE 85AMP
9	2R-Y5092	4	FEET ADJ 4GRAY 3/8-16
10	2J-30516	2	LIGHT SIGNAL AMBER
11	2R-30583	1	KNOB ASSY FRONT HOTPLATE
12	2R-30584	1	KNOB ASSY REAR HOTPLATE
13	2C-31697	AR	SCREW 8-32X3/16 PH RD HD
14	2C-33935	AR	SCREW 6ABX5/16 PH PAN SMS
15	D8-30256	2	TRIM RING ASSY
16	2E-30562	2	SWITCH INFINITE 240V
17	2M-300534	1	TRADEMARK DOMED LABEL
18	2K-31040	1	BUSHING 7/8 OD

EXPLODED VIEW: H70

H-70 COUNTERTOP ELECTRIC HOTPLATE - 208/240V - SOLID (FRENCH PLATE) ELEMENT

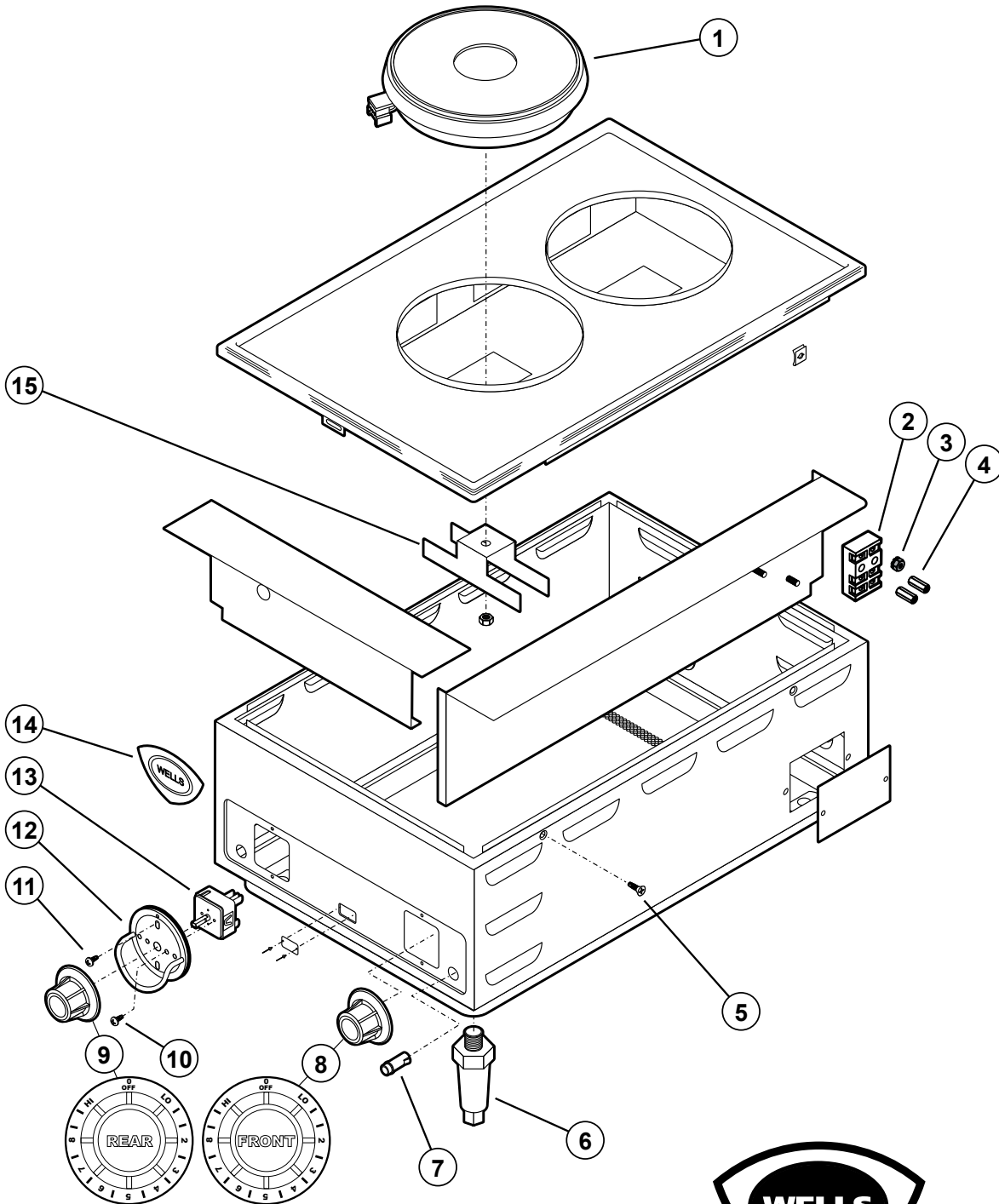

Model: H70
 Countertop Electric Hotplate - 208/240V - French Plate

PL221



IL1750 Rev. B 8/20/09

221 p/n 2M-303733 Owners Manual CT Hotplate

H70 COUNTERTOP ELECTRIC HOTPLATE 208/240V			
Fig No	Part No	Qty	Description
1	WS-503973	2	ELEM HOTPLATE UPGRADE FUSED
2	2C-41974	2	NUT 8-32 HEX 7/8 LONG ALU
3	2C-35736	2	NUT 8-32 HEX KEPS MS GREEN
4	WS-50131	1	TERM BLOCK KIT (RETRO 301)
5	2C-34285	4	SCREW 8-32X3/8 PH
6	2R-Y5092	4	FEET ADJ 4GRAY 3/8-16
7	2J-30516	2	LIGHT SIGNAL AMBER
8	2R-30583	1	KNOB ASSY FRONT HOTPLATE
9	2R-30584	1	KNOB ASSY REAR HOTPLATE
10	2C-31697	AR	SCREW 8-32X3/16 PH RD HD
11	2C-33935	AR	SCREW 6ABX5/16 PH PAN SMS
12	D8-30256	2	TRIM RING ASSY
13	2E-30562	2	SWITCH INFINITE 240V
14	2M-300534	1	TRADEMARK DOMED LABEL
15	I7-35031	2	CLAMP ELEM H70

EXPLODED VIEW: H115

H-115 COUNTERTOP ELECTRIC HOTPLATE - 120V - SPIRAL ELEMENT

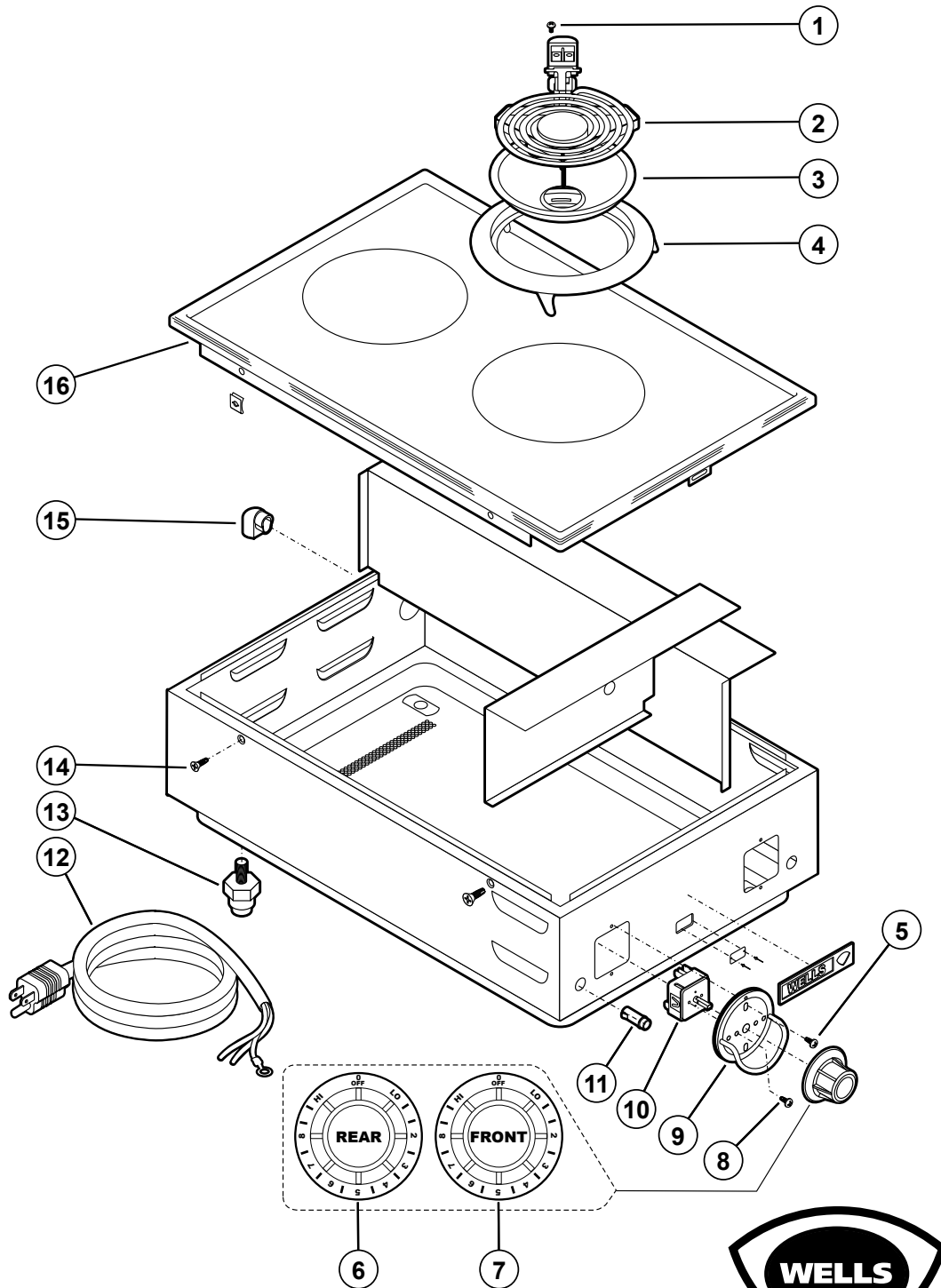

Model: H115
Countertop Electric Hotplate - 120V - Spiral Element
 PL221



IL1751 Rev. B 7/15/13

221 p/n 2M-303733 Owners Manual CT Hotplate

H115 COUNTERTOP ELECTRIC HOTPLATE 120V

Fig No	Part No	Qty	Description
1	2C-33977	2	SCREW 8-32X3/8 PH BND HD
2	2N-33573ELUL	2	ELEMENT 120V 825W H115
3	2D-30514DT	2	DRIP TRAY
4	I7-30514CR	2	ASSY CLIPS & RING
5	2C-33935	AR	SCREW 6ABX5/16 PH PAN SMS
6	2R-30584	1	KNOB RR HP91
7	2R-30583	1	KNOB ASSY FRONT HOTPLATE
8	2C-31697	AR	SCREW 8-32X3/16 PH RD HD
9	D8-30256	2	TRIM RING ASSY
10	2E-30570	2	SWITCH INFINITE 120V
11	2J-30516	2	LIGHT SIGNAL AMBER
12	2E-35539	1	CORD SET 120V 15A 16GA
13	2A-41946	4	LEG ADJUST 1 INCH
14	2C-34285	4	SCREW 8-32X3/8 PH 100 FL
15	2K-31217	1	STRAIN RELIEF 90DEG
16	I7-31103	1	TOP ASSY H115

WIRING DIAGRAM

WIRING DIAGRAM FOR ELECTRIC COUNTER TOP HOTPLATES H-63, H-65, H-70 and H-115

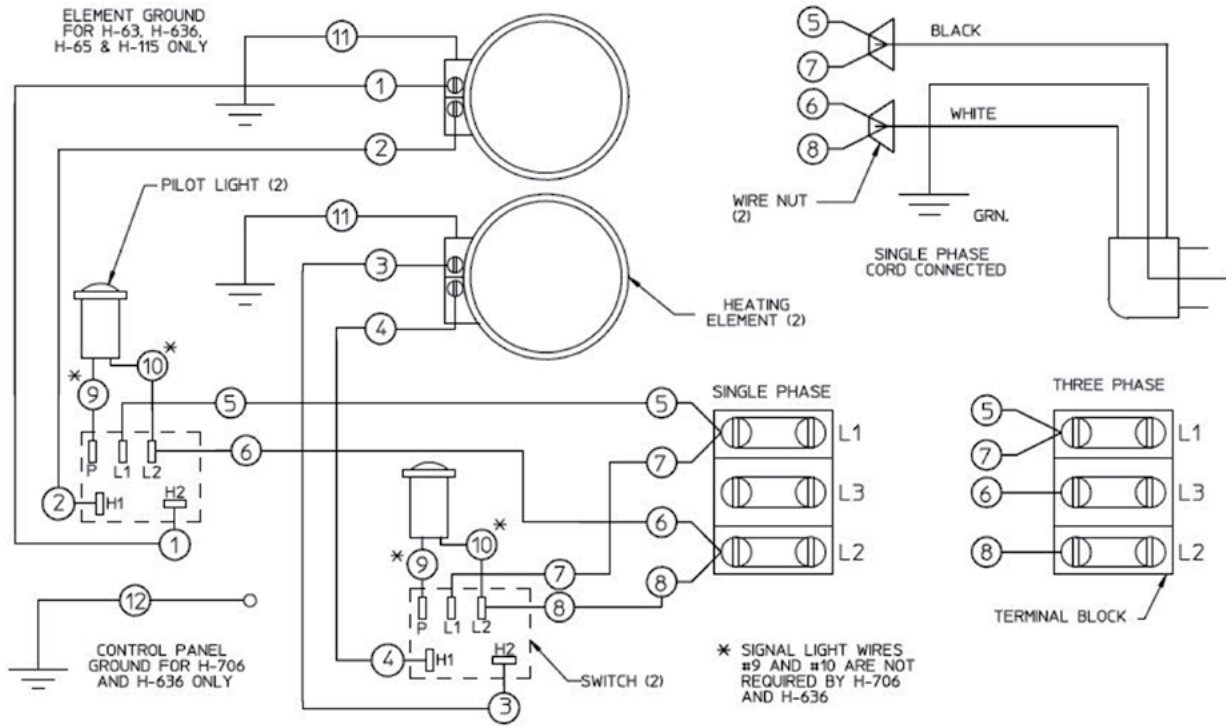

MODELS	VOLTS	AMPS 3 PHASE			AMPS 1 PHASE	FREQ.
		L1	L2	L3		
H-70 AND H-706	208	12.5	7.2	7.2	14.4	50 / 60 HZ
	240	14.4	8.3	8.3	16.7	
H-63, H-65 AND H-636		16.3	9.4	9.4	18.8	
		18.8	10.8	10.8	21.7	
H-115	120	-	-	-	13.8	

REV. A P/N 300093

WIRING DIAGRAM

WIRING DIAGRAM FOR H-33 120V SINGLE PHASE SER. NO. HS-1000 & UP

VOLTS	AMPS
120	12.5

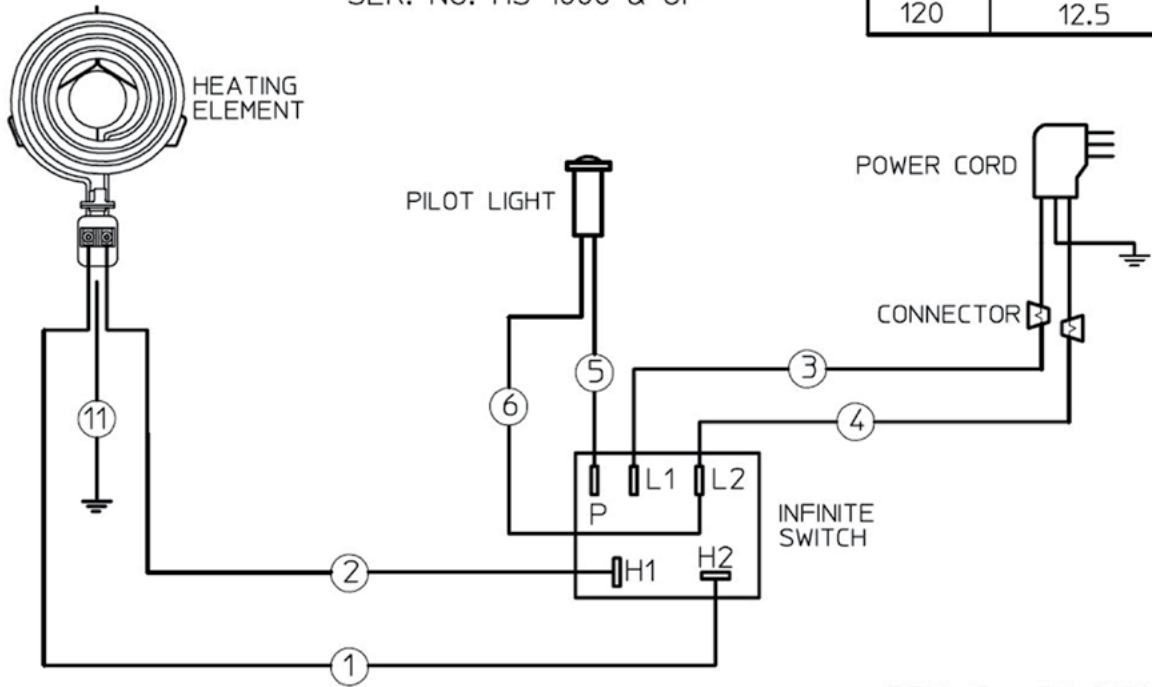

REV. G PN 31286

NOTES

PARTS & SERVICE

DESCRIPTION

SERVICE PART NO.

4" LEGS, Plastic, Set of 4	2R-Y5092
4" LEGS, Nickel Plated Alloy, Set of 4	2A-35483
Drip Tray, 8" for H-63, H-65	17-30292

IMPORTANT: Use only factory authorized service parts and replacement filters.

For factory authorized service, or to order factory authorized replacement parts, contact your Wells authorized service agency, or call:

Wells Manufacturing
10 Sunnen Dr. St. Louis MO
63143 USA

Service Dept.
phone: (314) 678-6314
fax: (314) 781-2714

Service Parts Department can supply you with the name and telephone number of the **WELLS AUTHORIZED SERVICE AGENCY** nearest you.

CUSTOMER SERVICE DATA

please have this information available if calling for service

RESTAURANT _____ LOCATION _____

INSTALLATION DATE _____ TECHNICIAN _____

SERVICE COMPANY _____

ADDRESS _____ STATE _____ ZIP _____

TELEPHONE NUMBER (____) _____ - _____

EQUIPMENT MODEL NO. _____

EQUIPMENT SERIAL NO. _____

VOLTAGE: (check one) 120V 208V 240V



Wells Bloomfield proudly supports CFESA
Commercial Food Equipment Service Association

SERVICE TRAINING - QUALITY SERVICE



CUSTOMER SATISFACTION



WELLS MANUFACTURING

10 Sunnen Dr., St. Louis, MO 63143

telephone: 314-678-6314

fax: 314-781-2714

www.wellsbloomfield.com