

Item No. \_\_\_\_\_

Quantity \_\_\_\_\_

**Models No.**

**8050SX-RC, 8075SX-RC**

## **Roller Grill with Digital Temperature Readout**

Nemco's roller grills have always been famous for their superior diehard cooking performance. 360° roller rotation prevents residue buildup, while individual roller heating elements ensure heating consistency. Removable drip pan makes for easy cleaning. Requires no ventilation system. Infinite controls offer versatile temperature control. Front and rear rollers have their own heat controls. This feature permits shutting off one section during non peak hours. A digital readout that displays the approximate food temperature of the product for both zones. Easy access to the two motors and chain from side panels. Non Slip Coating, GripsIt – this coating makes clean up easy for those sugary-coated products and breakfast items.

### **Standard Features:**

- Rugged stainless steel construction
- Simplest installation – plugs into any outlet with corresponding voltage
- GripsIt Rollers
- Easy to see color coded grease seals to identify front (black) and rear (white) rollers
- Rollers rotate at a complete 360° turn by means of a roller sprocket, motor sprocket and chain
- End bearing and grease barrier double protect against grease seepage
- Control cover
- 4" adjustable legs
- One year parts and labor warranty
- ETL, ETL CSA & NSF Listed

### **Note:**

The chains that drive the rollers should be inspected and greased once a year to be sure that they continue to operate correctly. This will allow the machine to operate for a much longer time.



Roller Grill with control cover



NEMCO Food Equipment, Ltd.  
301 Meuse Argonne Ave.  
Hicksville, OH 43526  
Phone 419-542-7751  
FAX 419-542-6690  
[www.nemcofoodequip.com](http://www.nemcofoodequip.com)

Printed 11/17 Printed in U.S.A.

## Roller Grill with Digital Temperature Readout

### Models No.

8050SX-RC, 8075SX-RC

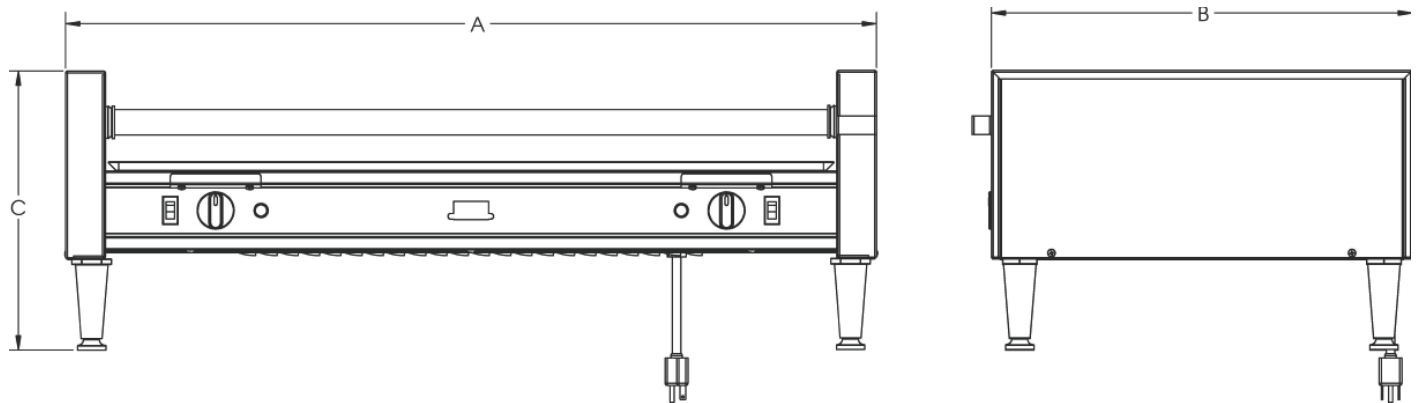

### SPECIFICATIONS

| Model #   | Hot Dog Capacity    | Width Inches (cm)<br>A | Depth Inches (cm)<br>B | Height Inches (cm)<br>C | Voltage | Wattage | Nominal Amps | NEMA Plug | Unit Weight lbs./ (kg) | Shipping Weight lbs./ (kg) |
|-----------|---------------------|------------------------|------------------------|-------------------------|---------|---------|--------------|-----------|------------------------|----------------------------|
| 8050SX-RC | 50<br>(6" Hot Dogs) | 35 3/4"<br>(90.8)      | 19 1/2"<br>(49.5)      | 12 1/4"<br>(31.1)       | 120     | 1430    | 11.9         | 5-15 P    | 60<br>(27.2)           | 70<br>(31.8)               |
| 8075SX-RC | 75<br>(6" Hot Dogs) | 35 3/4"<br>(90.8)      | 27 1/4"<br>(69.2)      | 12 1/4"<br>(31.1)       | 120     | 1920    | 16.0         | 5-20 P    | 80<br>(36.2)           | 90<br>(40.8)               |

(SX) Denotes special non-slip GripsIt coating

### TYPICAL SPECIFICATIONS

Roller Grill shall be stainless steel construction and use a special non-slip *GripsIt* rollers and tubular heating elements. One element shall be contained in each roller. Unit shall have a sealed motor with ball bearings for long life. Each roller shall have a PTFE end bearing and silicone grease barrier combination. The unit shall be equipped with two indicator lights and operate on 120 Volts (60Hz) with one 6' cord and NEMA 5-15P (8050SX-RC) or 5-20P (8075SX-RC). This Roller Grill shall carry the approval of ETL, ETL CSA and is listed with the National Sanitation Foundation.

**nemco**® | FOOD  
EQUIPMENT

NEMCO Food Equipment, Ltd.  
301 Meuse Argonne Ave.  
Hicksville, OH 43526  
Phone 419-542-7751  
FAX 419-542-6690  
[www.nemcofoodequip.com](http://www.nemcofoodequip.com)  
11/17 Printed in U.S.A.