



K-200 SERIES

HOT WATER SANITIZING SINGLE-TANK RACK CONVEYOR WAREWASHERS

Meiko's K-Tronic series rack conveyor warewashers combine state-of-the-art advanced features with economical and reliable operation. The K-Tronic series features the lowest water consumption of any NSF-rated rack conveyor warewasher, and makes use of an exclusive pumped, heated auxiliary rinse zone to make use of the rinse water a second time for pristine, consistent results. Meiko's exclusive Waste Air Heat Recovery System reclaims the waste air generated by the machine as free energy to pre-heat the incoming rinse water, saving energy.

Other standard features include computer-positioned wash arms (and prewash arms, on models so equipped) that are pre-assembled into easily-removed manifolds. Wash nozzles are slotted and concave to minimize clogging, and feature captivated end caps which can't be lost during cleaning. K-Tronic series machines also feature Meiko's Mike 3 electronic controller, and double-wall insulated construction. As with all products synonymous with the name "Meiko," engineering excellence, manufacturing quality and performance come to the forefront in the K-Tronic series rack conveyors.

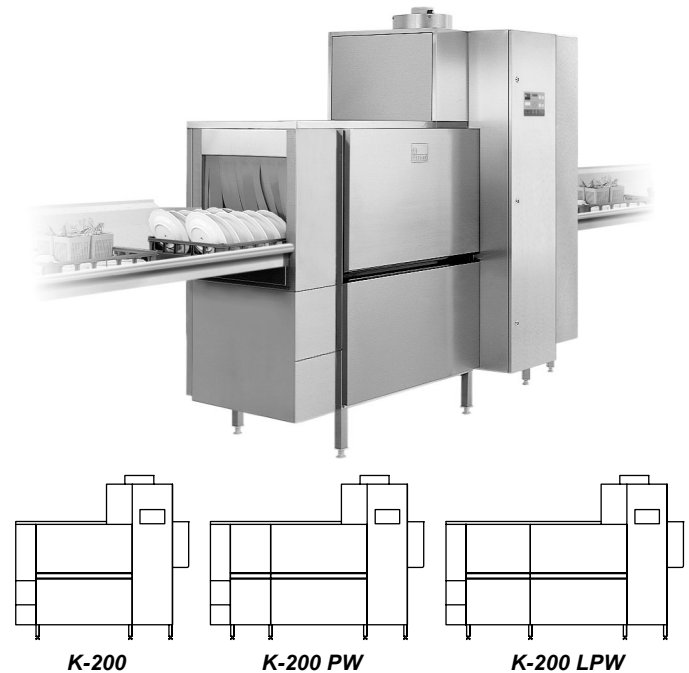

- **Model K-200** includes a 6' 4-3/4" chamber with one pumped wash section (with 3 hp pump), pumped auxiliary rinse section (with 3 hp pump) and pumped final rinse section (with 3/4 hp pump).
- **Model K-200 PW** adds a 19-5/8" prewash section (with 3/4 hp pump) to the base K-200 model (overall length 8' 1/2").
- **Model K-200 LPW** adds a 31-1/2" prewash section (with 3 hp pump) to the base K-200 model (overall length 9' 1/4").

Exclusive Features:

- **The K-Tronic series features the lowest water consumption in the industry.** Model K-200 consumes 0.35 gallons per rack.
- **Pumped auxiliary rinse zone** supplements the final rinse zone, providing pristine, consistent results.
- **Waste air heat recovery system** reclaims heat generated by the machine and uses it as free energy to preheat the incoming rinse water, reducing energy consumption and allowing hot-water sanitizing from a cold water supply (50°F).
- **Double-wall insulated construction** retains heat inside the machine, conserving energy and improving the working environment.
- **Improved drive system** permits fast, smooth conveyor travel. Rack rail-mounted pawl system does not obstruct the wash pattern.
- **Mike 3 electronic controller** for fully automatic operation and advanced service diagnostics. Wash and final rinse are activated only when a rack is in place to conserve water and detergent.

Standard Features:

- Computer-positioned wash arms in easily-removed manifolds feature concave, slotted nozzles to minimize clogging, and captivated end caps.
- Front-sloping wash tanks
- All 304-series stainless steel construction
- Large, easily-removed pan strainers. Models equipped with a prewash include a separate prewash scrap basket.
- Powerful 3hp wash pump is vertically-mounted to be self-draining and easily removed for servicing.
- Single-point drain connection
- Single-point ventilation connection
- Low-level heater protection

Options:

- Revolutionary blower drying system - uses only 3 kW for heating. Available in two lengths: 23-5/8" (600mm) or 35-1/2" (900mm)
- CSS Top Chemical Savings System
- Hinged front access doors
- Steam coil or electric tank heating
- Table limit switch
- External vent fan control
- Single-point electrical connection
- 90° loaders and power unloaders



US LISTED



K-200, K-200 PW, K-200 LPW, electric heating Machines without blower dryer, Left-to-Right

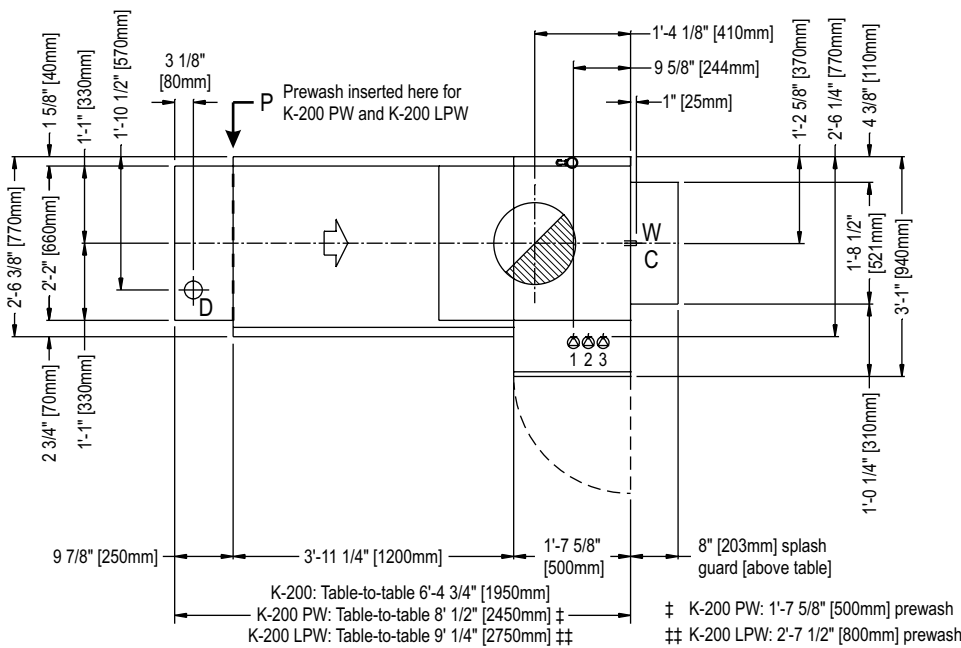
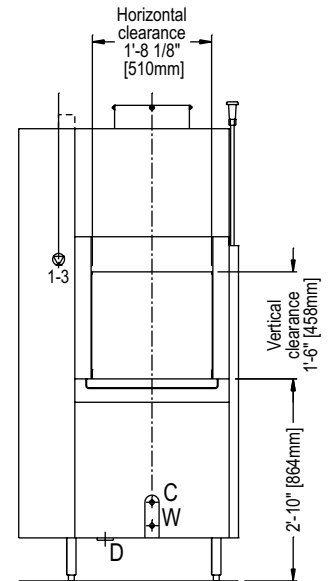
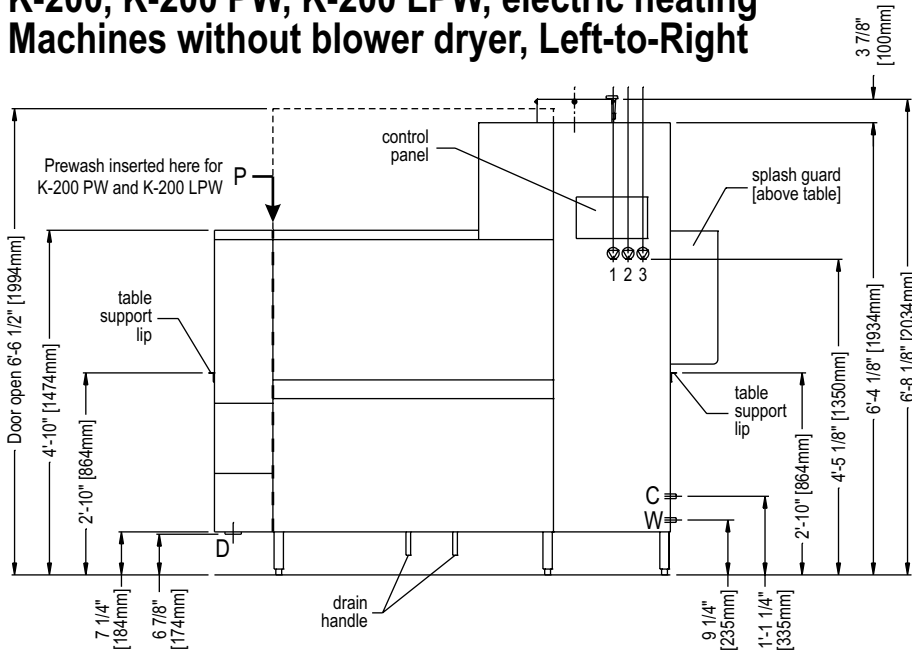

CSS TOP OPTION (front view)

9-7/8" [250mm] load section is replaced with CSS Top section. Adds 1'-7 5/8" [500mm] to overall machine length.

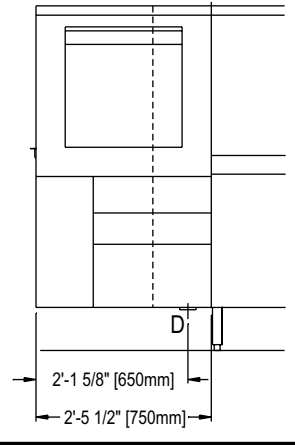

UTILITY CONNECTIONS

D Drain
2-15/16" (75mm) OD vertical, gravity-fed drain outlet (HDPE piping). Optional 3" NPT male adapter supplied. Recommend placement directly above 4" floor drain. Additional piping to drain (if so required) to be supplied by customer.

Electrical connection
3 (three) individual terminal blocks at locations shown. Each connection is 4-wire with ground (no neutral). Individual disconnect with lockout/tagout strongly recommended for each supply (provided by customer). Incoming leads must be appropriately sized for electrical supply. Opening(s) in the machine for the supply lines are NOT provided and should be executed on-site using appropriate strain relief device(s). Refer to Page 10 for supply details.

Vent connection
354 CFM (+120 CFM room air recommended)

W Warm water connection (fill)
3/4" NPT female pipe connection
• Temperature 110-140°F (43-60°C)
• Pressure 15-25 PSI
• Initial fill - Refer to Page 10
• Hardness 4-6 grains/U.S. gal.

C Cold water connection (rinse)
3/4" NPT female pipe connection
• Temperature 50°F (10°C)
• Pressure 15-25 PSI
• Consumption 84.7 U.S. gals./hour
• Hardness 4-6 grains/U.S. gal.

DETAIL VIEW: VENT

The vent shroud MUST NOT be connected directly to the machine, as this prevents room air from being drawn into the shroud. All dimensions shown are recommendations only. Actual exhaust connection must be adequate for the exhaust air and comply with all applicable national and local codes.

The waste air connection must be corrosion-resistant and frost-free. In particular, provision must be made to prevent air temperatures of 32°F/0°C or colder from reaching the machine at any time. A provision for draining moisture from the waste air pipe is STRONGLY RECOMMENDED.

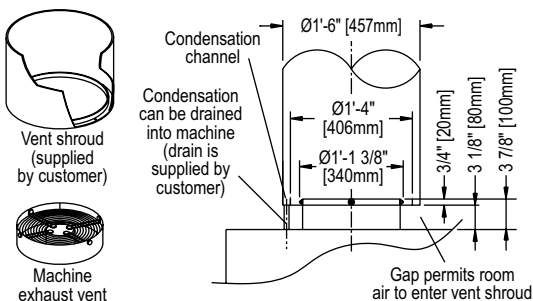

K-200, K-200 PW, K-200 LPW, electric heating Machines without blower dryer, Right-to-Left

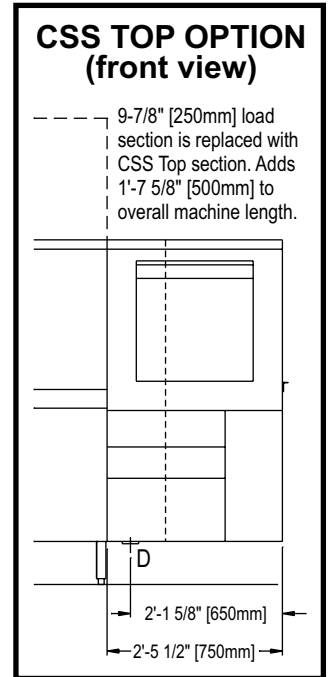
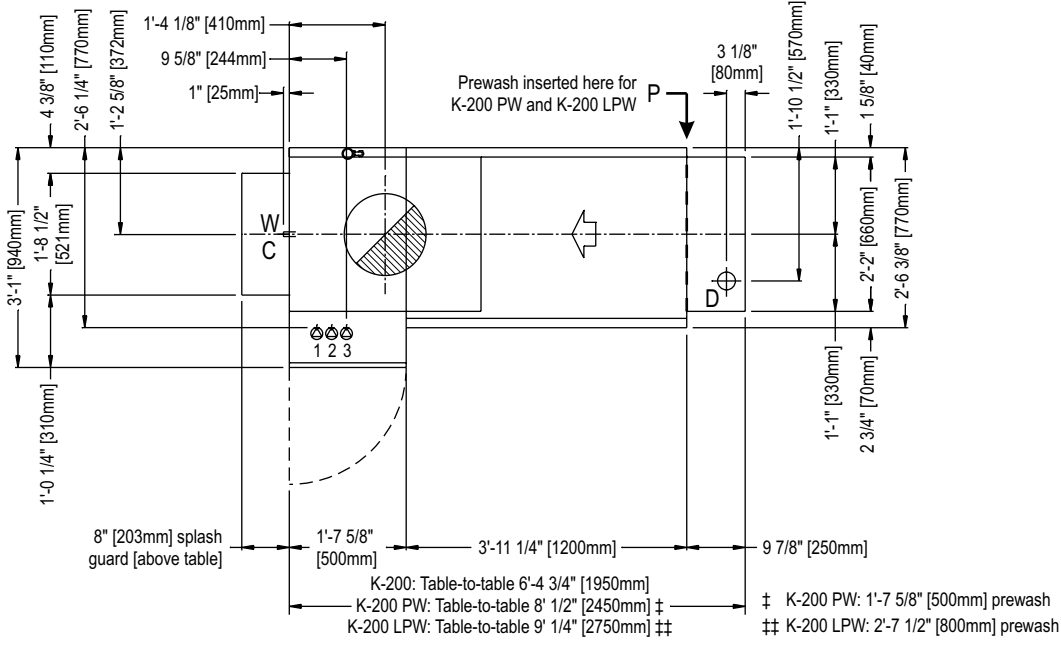
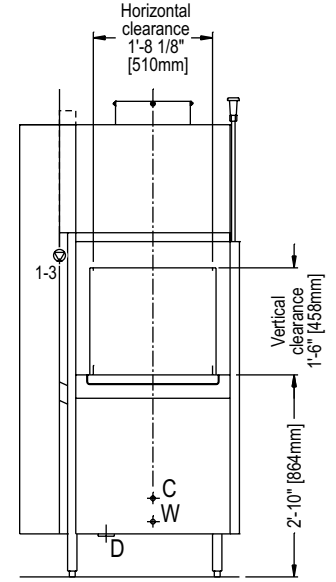
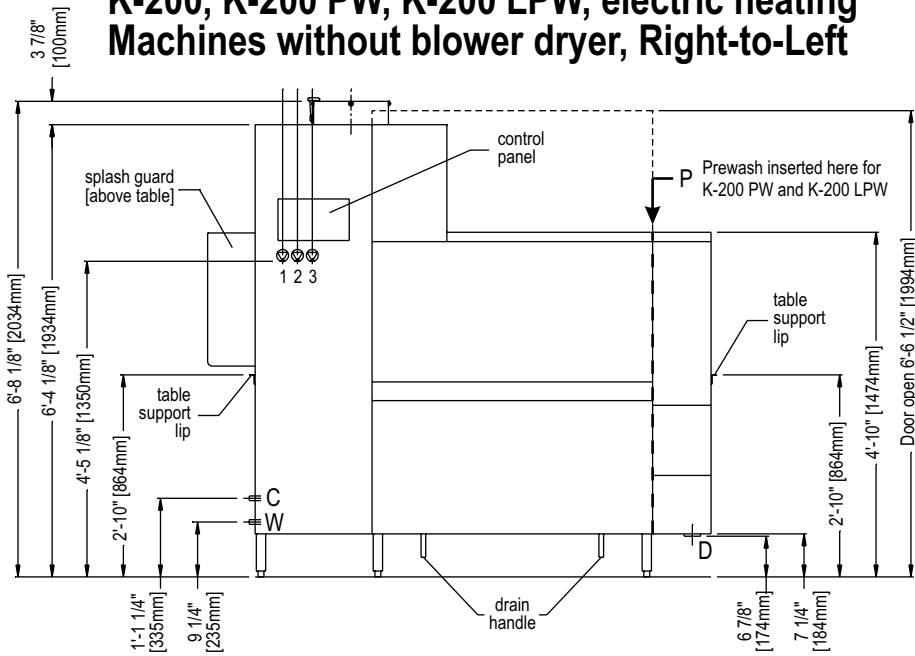

DETAIL VIEW: DRAIN

The machine is equipped with a 2-15/16" (75mm) OD vertical, gravity-fed drain. If possible, the machine drain can simply be positioned directly above a 4" floor drain.

If a floor drain is not in the correct location, or if local codes require a trap, a 3" indirect drain line may be attached using the supplied boot, clamp, and 3" NPT male adapter.

Choose a piping material that:

- Complies with any applicable local and national codes
- Is rated for use with water temperatures up to 180°F/82°C
- Is rated for 3-12 pH to accommodate detergents and rinse aid in the drain water

Direct drain (recommended if possible)

To 3" indirect drain line (supplied by customer)

Machine drain, Boot (supplied), Clamp (supplied), 3" NPT male adapter, HDPE (supplied)

Dimensions: 6 7/8" [174mm], 3 1/2" [90mm]

DETAIL VIEW: TABLING

Wall clearances shown are for typical 30" D dishtable. Actual clearances will depend upon table manufacturer and table dimensions.

Feeding and discharge tables to be supplied by others

Table lip-in height 2'-10" [864mm] A.F.F.

22" [559mm] max. 20-1/2" [521mm] recommended

1" [25mm] max.

2'-6" [762mm], 1'-6 1/8" [462mm], 5 1/8" [132mm], 3 5/8" [92mm]

K-200, K-200 PW, K-200 LPW, electric heating Machines with blower dryer, Left-to-Right

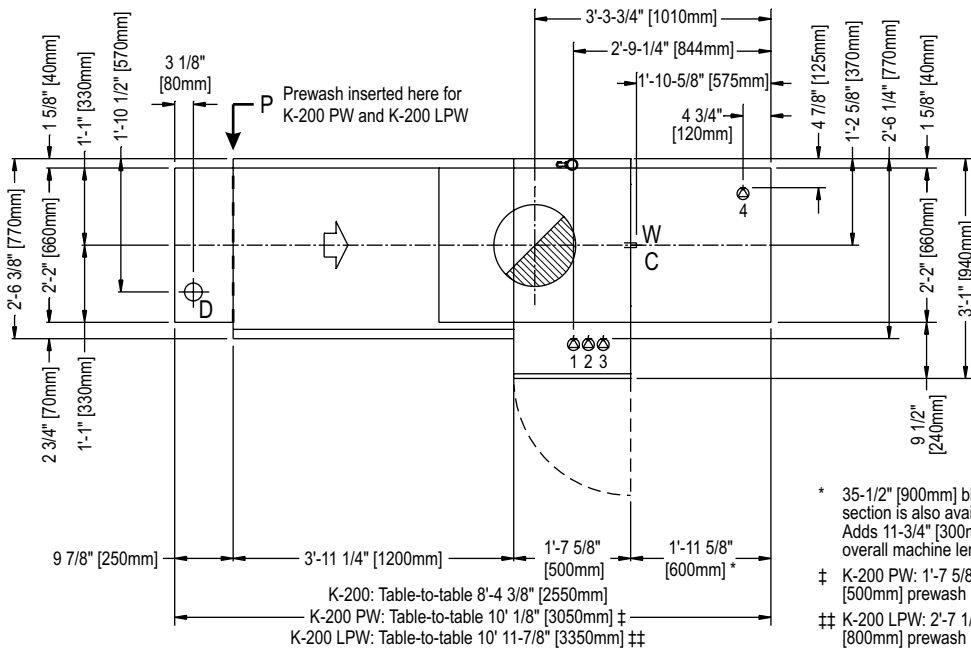
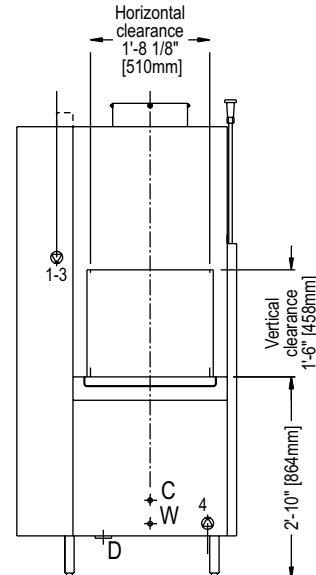
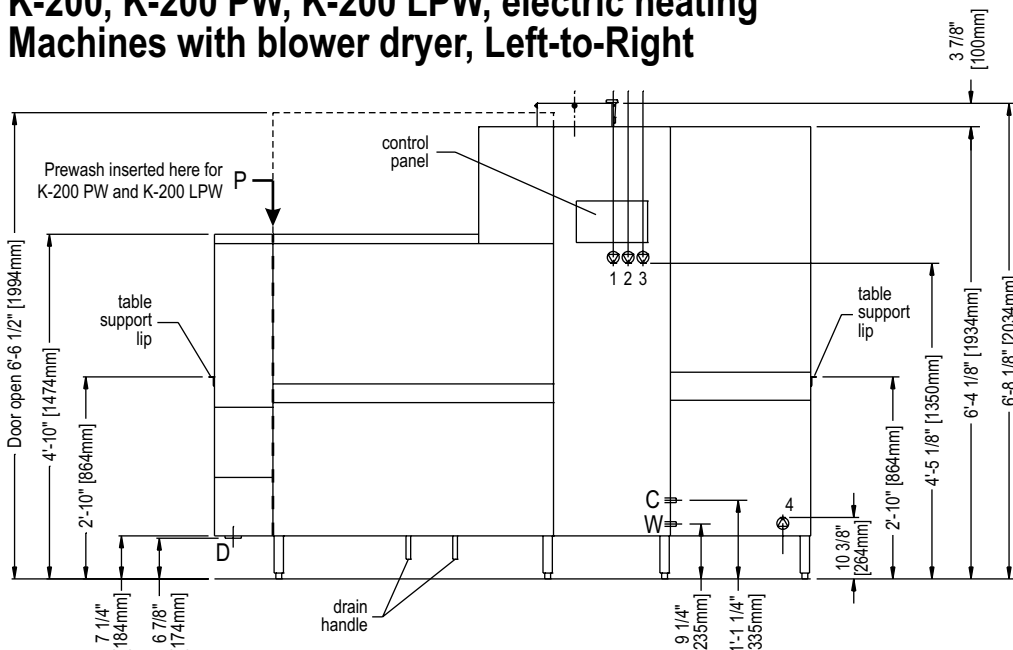

* 35-1/2" [900mm] blower dryer section is also available. Adds 11-3/4" [300mm] to overall machine length.
‡ K-200 PW: 1'-7 5/8" [500mm] prewash
‡‡ K-200 LPW: 2'-7 1/2" [800mm] prewash

CSS TOP OPTION (front view)

9-7/8" [250mm] load section is replaced with CSS Top section. Adds 1'-7 5/8" [500mm] to overall machine length.

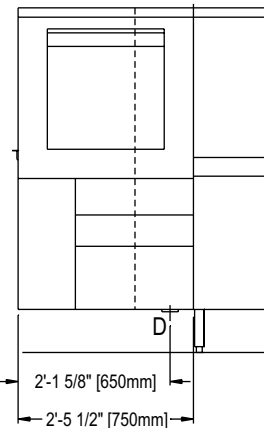

UTILITY CONNECTIONS

D Drain

2-15/16" (75mm) OD vertical, gravity-fed drain outlet (HDPE piping). Optional 3" NPT male adapter supplied. Recommend placement directly above 4" floor drain. Additional piping to drain (if so required) to be supplied by customer.



Electrical connection

4 (four) individual terminal blocks at locations shown. Each connection is 4-wire with ground (no neutral). Individual disconnect with lockout/tagout strongly recommended for each supply (provided by customer). Incoming leads must be appropriately sized for electrical supply. Opening(s) in the machine for the supply lines are NOT provided and should be executed on-site using appropriate strain relief device(s). Refer to Page 10 for supply details.



Vent connection

383 CFM (+120 CFM room air recommended)

W Warm water connection (fill)

3/4" NPT female pipe connection
• Temperature 110-140°F (43-60°C)
• Pressure 15-25 PSI
• Initial fill - Refer to Page 10
• Hardness 4-6 grains/U.S. gal.

C Cold water connection (rinse)

3/4" NPT female pipe connection
• Temperature 50°F (10°C)
• Pressure 15-25 PSI
• Consumption 84.7 U.S. gals./hour
• Hardness 4-6 grains/U.S. gal.

DETAIL VIEW: VENT

The vent shroud MUST NOT be connected directly to the machine, as this prevents room air from being drawn into the shroud. All dimensions shown are recommendations only. Actual exhaust connection must be adequate for the exhaust air and comply with all applicable national and local codes.

The waste air connection must be corrosion-resistant and frost-free. In particular, provision must be made to prevent air temperatures of 32°F/0°C or colder from reaching the machine at any time. A provision for draining moisture from the waste air pipe is STRONGLY RECOMMENDED.

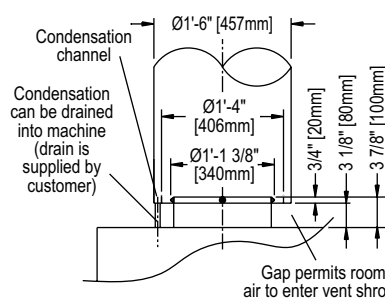
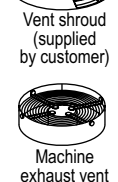
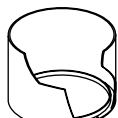

K-200, K-200 PW, K-200 LPW, electric heating Machines with blower dryer, Right-to-Left

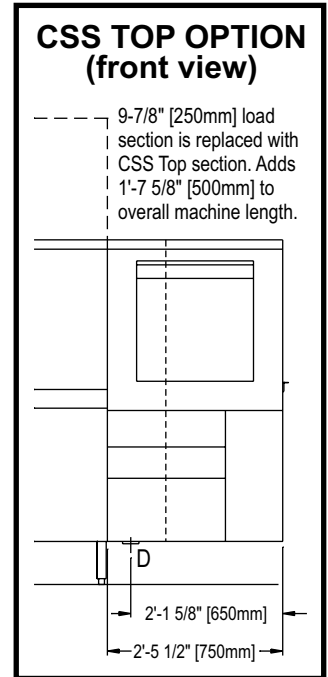
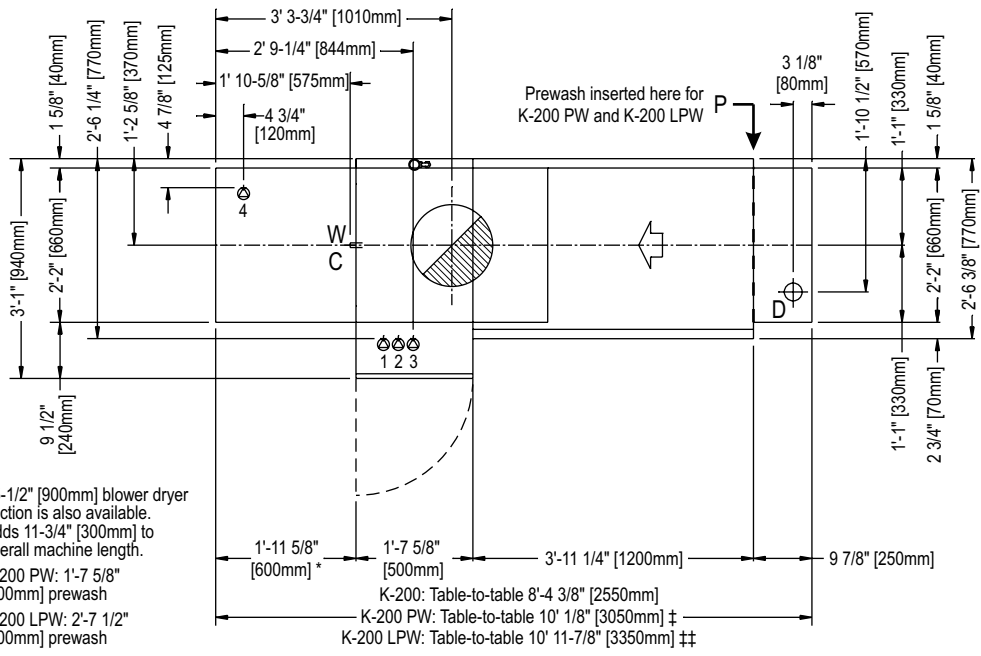
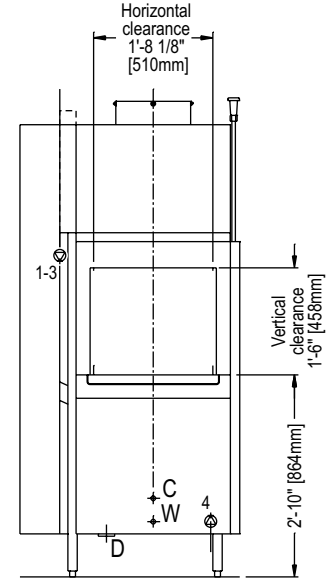
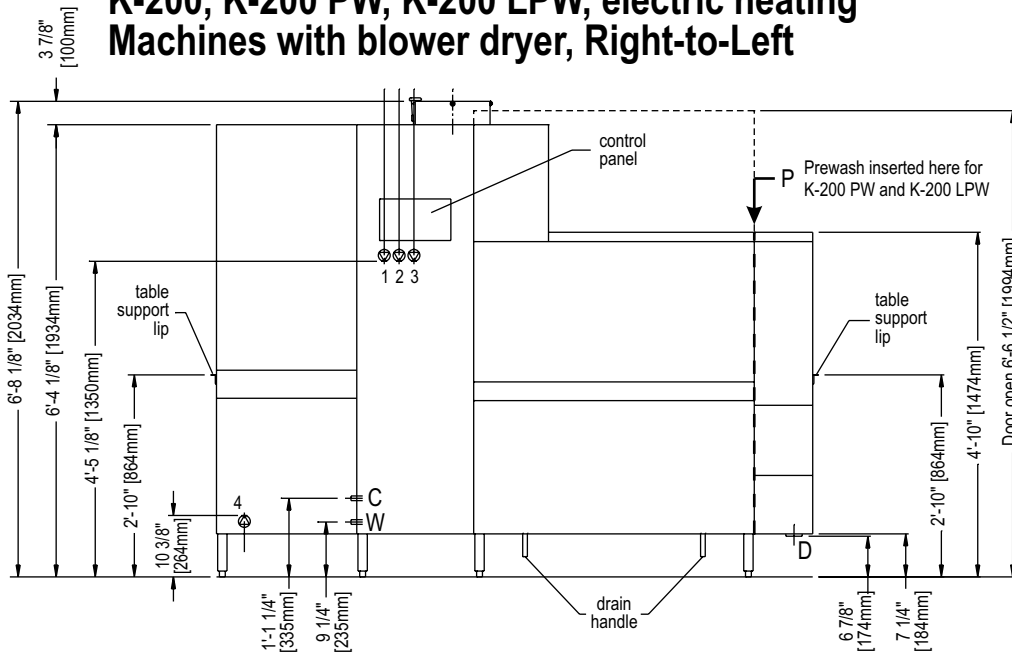

* 35-1/2" [900mm] blower dryer section is also available. Adds 11-3/4" [300mm] to overall machine length.

‡ K-200 PW: 1'-7 5/8" [500mm] prewash

‡‡ K-200 LPW: 2'-7 1/2" [800mm] prewash

DETAIL VIEW: DRAIN

The machine is equipped with a 2-15/16" (75mm) OD vertical, gravity-fed drain. If possible, the machine drain can simply be positioned directly above a 4" floor drain.

If a floor drain is not in the correct location, or if local codes require a trap, a 3" indirect drain line may be attached using the supplied boot, clamp, and 3" NPT male adapter.

Choose a piping material that:

- Complies with any applicable local and national codes
- Is rated for use with water temperatures up to 180°F/82°C
- Is rated for 3-12 pH to accommodate detergents and rinse aid in the drain water

Machine drain
Boot (supplied)
Clamp (supplied)
3" NPT male adapter, HDPE (supplied)

Direct drain (recommended if possible)

To 3" indirect drain line (supplied by customer)

6 7/8" [174mm]
3 1/2" [90mm]

DETAIL VIEW: TABLING

Wall clearances shown are for typical 30" D dishtable. Actual clearances will depend upon table manufacturer and table dimensions.

Feeding and discharge tables to be supplied by others

1" [25mm] max.

Table lip-in height 2'-10" [864mm] A.F.F.

22" [559mm] max.
20-1/2" [521mm] recommended

2'-6" [762mm]
1'-6 1/8" [462mm]
5 1/8" [132mm]
3 5/8" [92mm]

K-200, K-200 PW, K-200 LPW, steam coil heating Machines without blower dryer, Left-to-Right

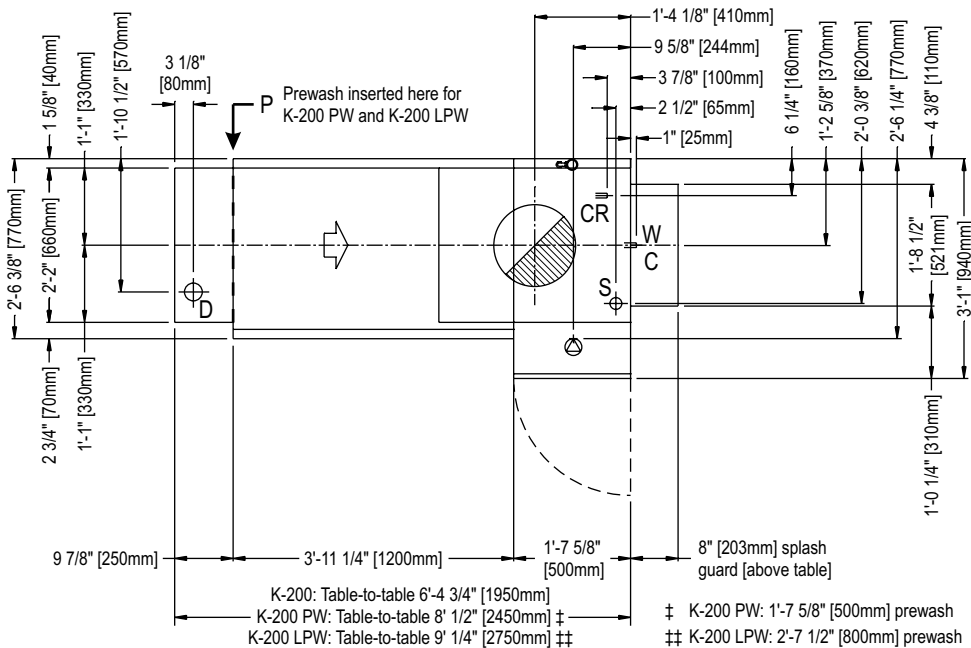
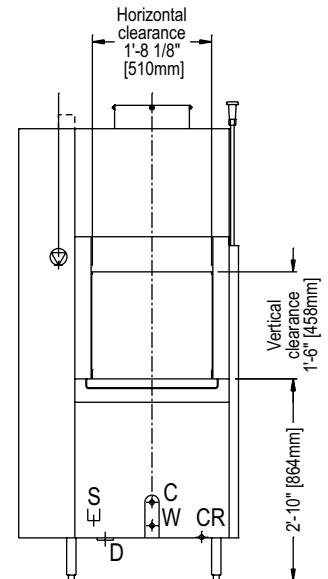
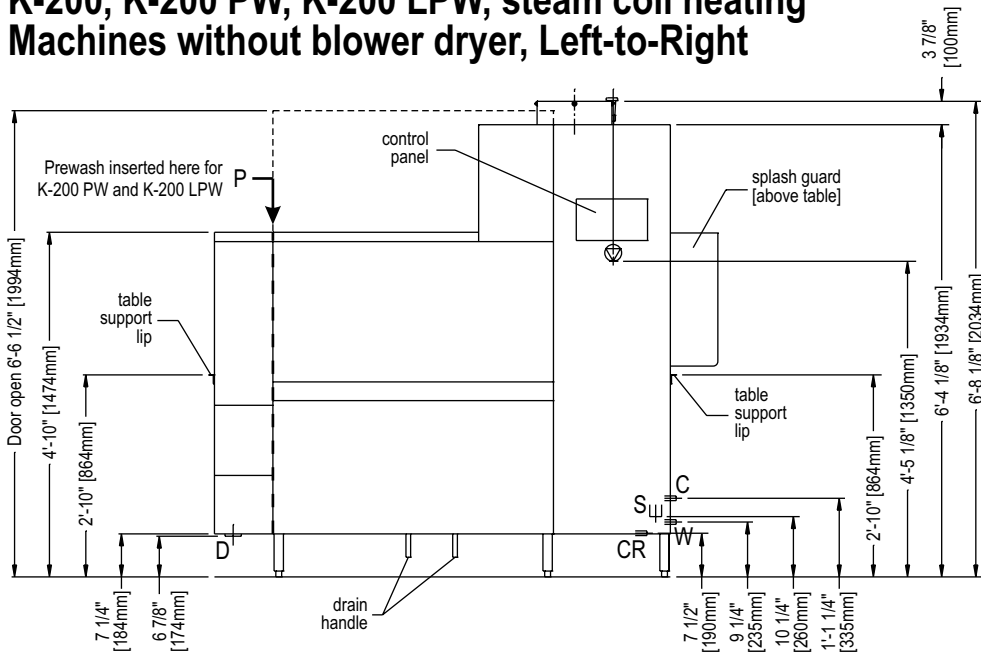

CSS TOP OPTION (front view)

9-7/8" [250mm] load section is replaced with CSS Top section. Adds 1'-7 5/8" [500mm] to overall machine length.

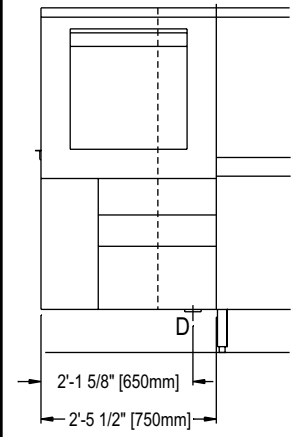

UTILITY CONNECTIONS

D Drain
2-15/16" (75mm) OD vertical, gravity-fed drain outlet (HDPE piping). Optional 3" NPT male adapter supplied. Recommend placement directly above 4" floor drain. Additional piping to drain (if so required) to be supplied by customer.

Electrical connection
1 (one) terminal block at location shown. Connection is 4-wire with ground (no neutral). Individual disconnect with lockout/tagout strongly recommended (provided by customer).
Incoming leads must be appropriately sized for electrical supply. Opening(s) in the machine for the supply lines are NOT provided and should be executed on-site using appropriate strain relief device. Refer to Page 10 for supply details.

Vent connection
354 CFM (+120 CFM room air recommended)

W Warm water connection (fill)
3/4" NPT female pipe connection
• Temperature 110-140°F (43-60°C)
• Pressure 15-25 PSI
• Initial fill - Refer to Page 10
• Hardness 4-6 grains/U.S. gal.

C Cold water connection (rinse)
3/4" NPT female pipe connection
• Temperature 50°F (10°C)
• Pressure 15-25 PSI
• Consumption 84.7 U.S. gals./hour
• Hardness 4-6 grains/U.S. gal.

S Steam connection
2" NPT pipe connection
• Pressure 10-29 PSI (1-2 bars)
• Consumption 187 lbs./hr. (51 kW)

CR Condensate return connection
1" NPT pipe connection

DETAIL VIEW: VENT

The vent shroud MUST NOT be connected directly to the machine, as this prevents room air from being drawn into the shroud. All dimensions shown are recommendations only. Actual exhaust connection must be adequate for the exhaust air and comply with all applicable national and local codes.

The waste air connection must be corrosion-resistant and frost-free. In particular, provision must be made to prevent air temperatures of 32°F/0°C or colder from reaching the machine at any time. A provision for draining moisture from the waste air pipe is STRONGLY RECOMMENDED.

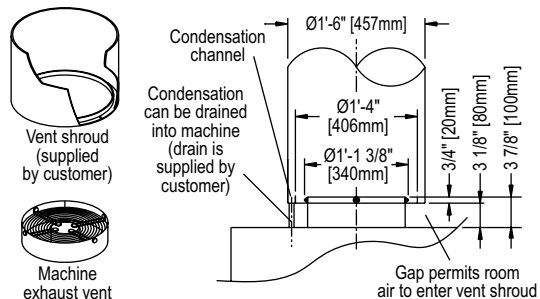

K-200, K-200 PW, K-200 LPW, steam coil heating Machines without blower dryer, Right-to-Left

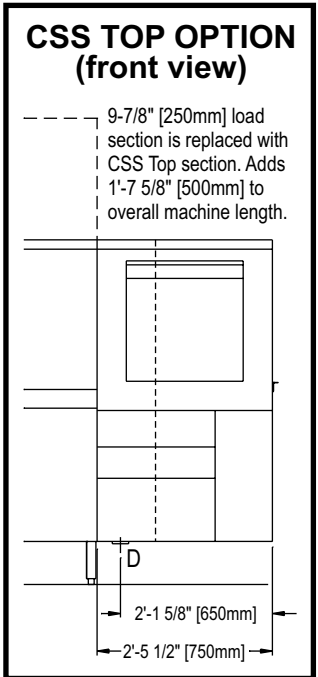
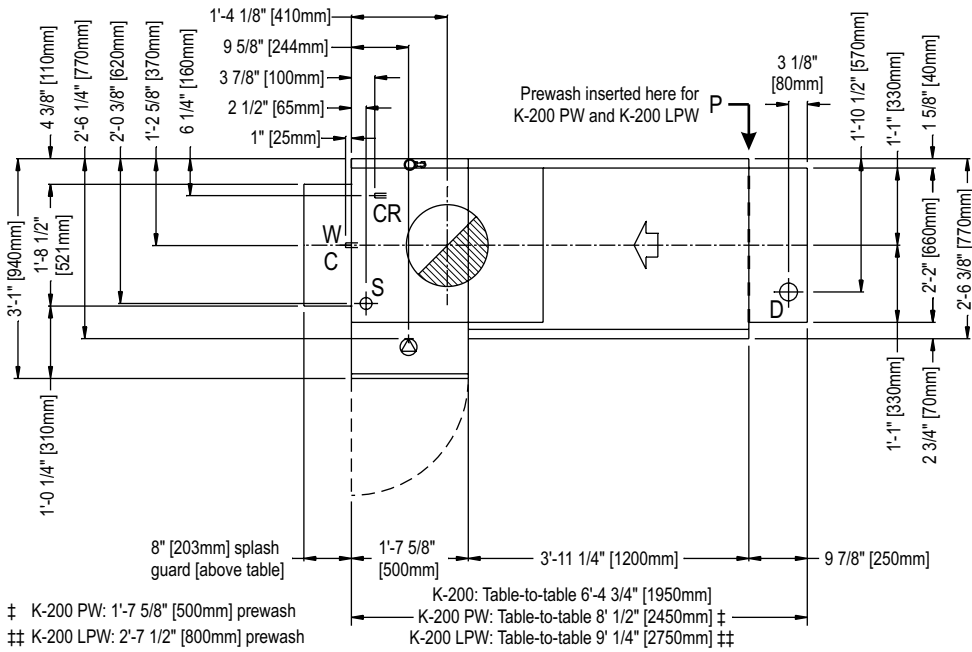
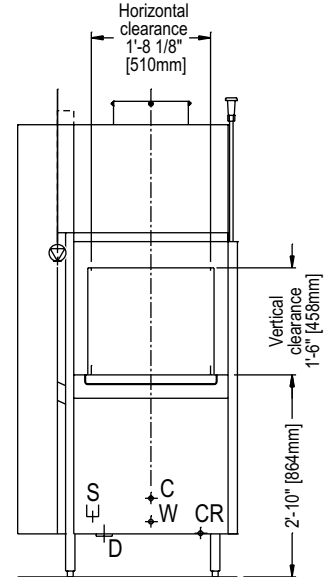
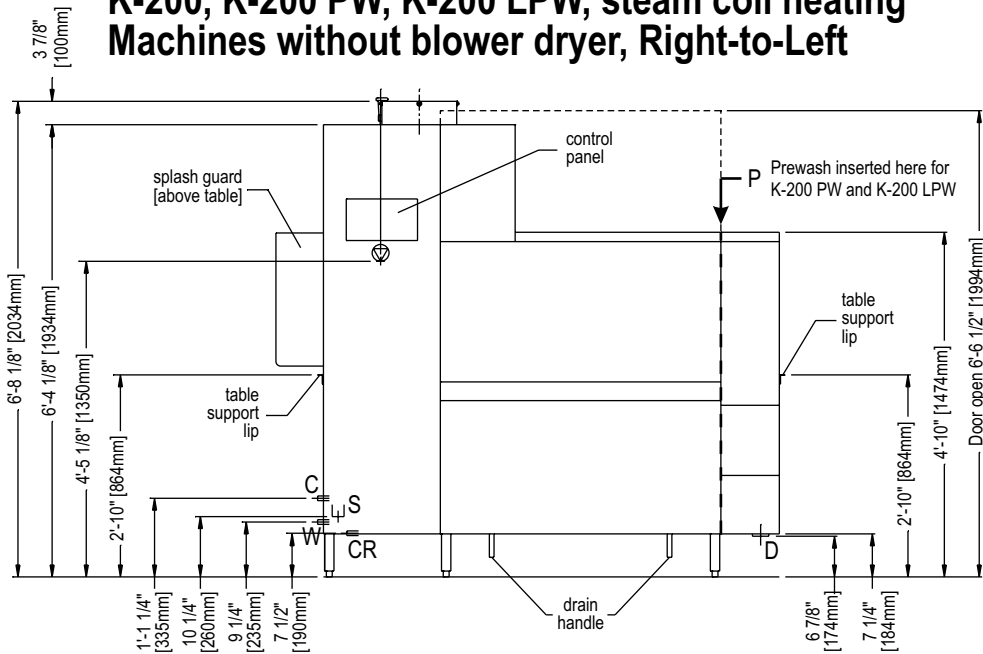

DETAIL VIEW: DRAIN

The machine is equipped with a 2-15/16" (75mm) OD vertical, gravity-fed drain. If possible, the machine drain can simply be positioned directly above a 4" floor drain.

If a floor drain is not in the correct location, or if local codes require a trap, a 3" indirect drain line may be attached using the supplied boot, clamp, and 3" NPT male adapter.

Choose a piping material that:

- Complies with any applicable local and national codes
- Is rated for use with water temperatures up to 180°F/82°C
- Is rated for 3-12 pH to accommodate detergents and rinse aid in the drain water

Machine drain
 Boot (supplied)
 Clamp (supplied)
 3" NPT male adapter, HDPE (supplied)

Direct drain (recommended if possible)
 To 3" indirect drain line (supplied by customer)

DETAIL VIEW: TABLING

Wall clearances shown are for typical 30" D dishtable. Actual clearances will depend upon table manufacturer and table dimensions.

Feeding and discharge tables to be supplied by others

Table lip-in height 2'-10" [864mm] A.F.F.
 22" [559mm] max.
 20-1/2" [521mm] recommended

1" [25mm] max.
 2'-6" [762mm]
 1'-6 1/8" [462mm]
 5 1/8" [132mm]
 3 5/8" [92mm]

K-200, K-200 PW, K-200 LPW, steam coil heating Machines with blower dryer, Left-to-Right

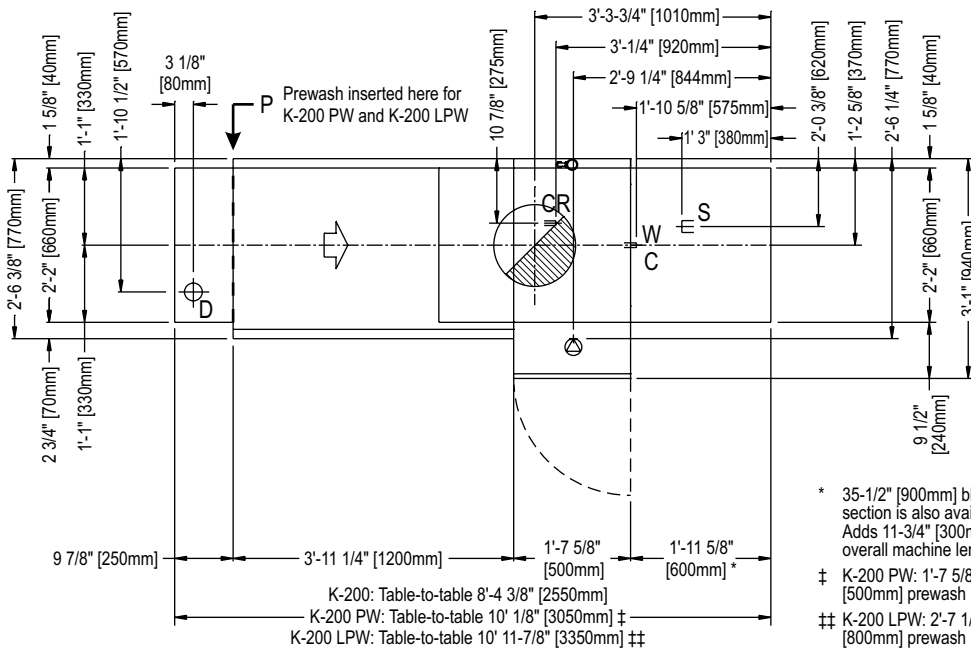
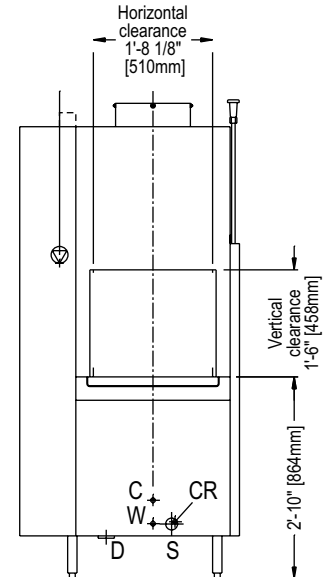
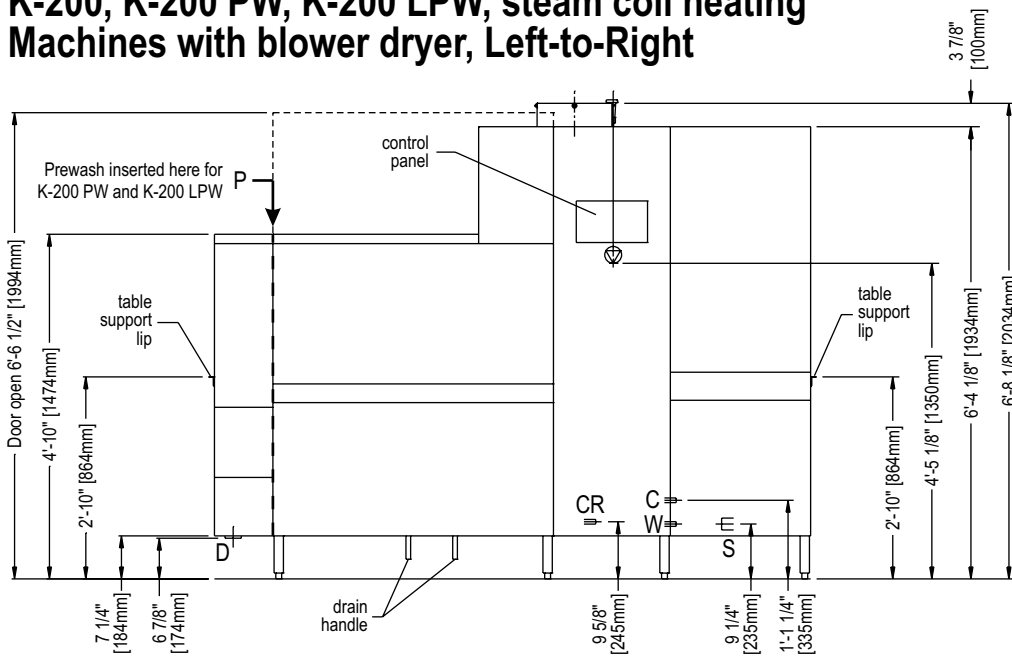

* 35-1/2" [900mm] blower dryer section is also available. Adds 11-3/4" [300mm] to overall machine length.
 † K-200 PW: 1'-7 5/8" [500mm] prewash
 ‡ K-200 LPW: 2'-7 1/2" [800mm] prewash

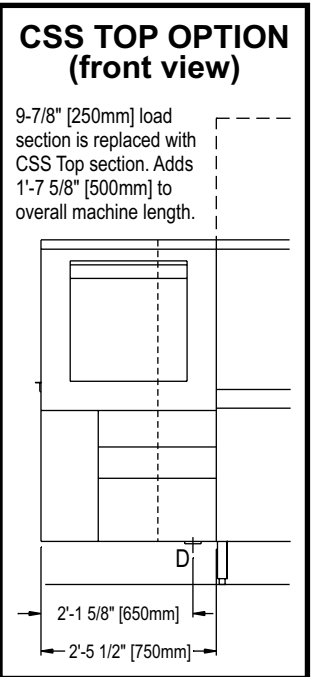

UTILITY CONNECTIONS

D Drain
 2-15/16" (75mm) OD vertical, gravity-fed drain outlet (HDPE piping). Optional 3" NPT male adapter supplied. Recommend placement directly above 4" floor drain. Additional piping to drain (if so required) to be supplied by customer.

Electrical connection
 1 (one) terminal block at location shown. Connection is 4-wire with ground (no neutral). Individual disconnect with lockout/tagout strongly recommended (provided by customer). Incoming leads must be appropriately sized for electrical supply. Opening(s) in the machine for the supply lines are NOT provided and should be executed on-site using appropriate strain relief device. Refer to Page 10 for supply details.

Vent connection
 383 CFM (+120 CFM room air recommended)

W Warm water connection (fill)
 3/4" NPT female pipe connection
 • Temperature 110-140°F (43-60°C)
 • Pressure 15-25 PSI
 • Initial fill - Refer to Page 10
 • Hardness 4-6 grains/U.S. gal.

C Cold water connection (rinse)
 3/4" NPT female pipe connection
 • Temperature 50°F (10°C)
 • Pressure 15-25 PSI
 • Consumption 84.7 U.S. gals./hour
 • Hardness 4-6 grains/U.S. gal.

S Steam connection
 2" NPT pipe connection
 • Pressure 10-29 PSI (1-2 bars)
 • Consumption 187 lbs./hr. (51 kW)

CR Condensate return connection
 1" NPT pipe connection

DETAIL VIEW: VENT

The vent shroud MUST NOT be connected directly to the machine, as this prevents room air from being drawn into the shroud. All dimensions shown are recommendations only. Actual exhaust connection must be adequate for the exhaust air and comply with all applicable national and local codes.

The waste air connection must be corrosion-resistant and frost-free. In particular, provision must be made to prevent air temperatures of 32°F/0°C or colder from reaching the machine at any time. A provision for draining moisture from the waste air pipe is STRONGLY RECOMMENDED.

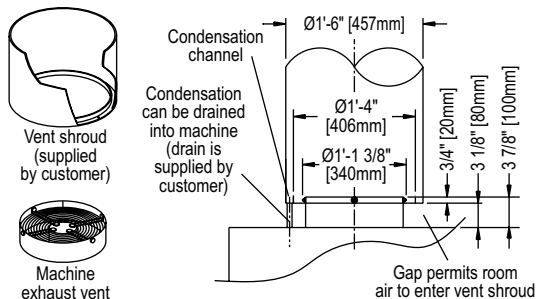

K-200, K-200 PW, K-200 LPW, steam coil heating Machines with blower dryer, Right-to-Left

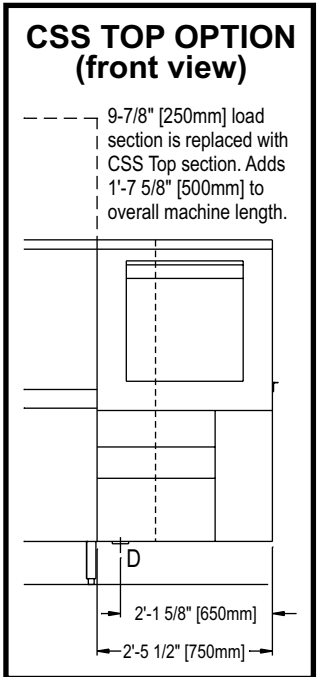
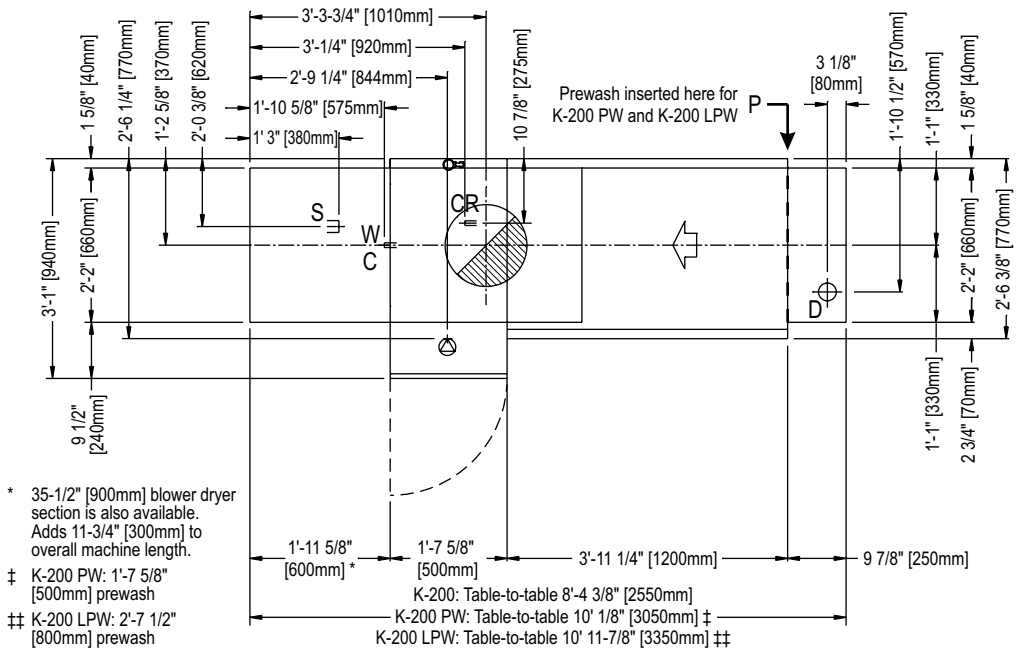
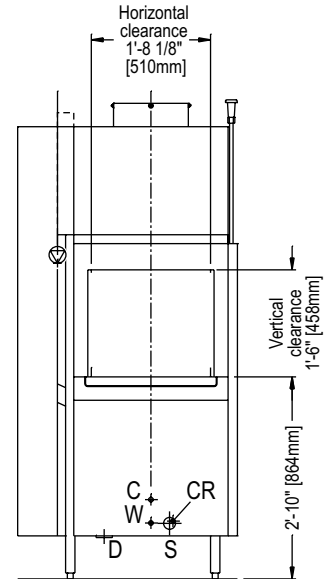
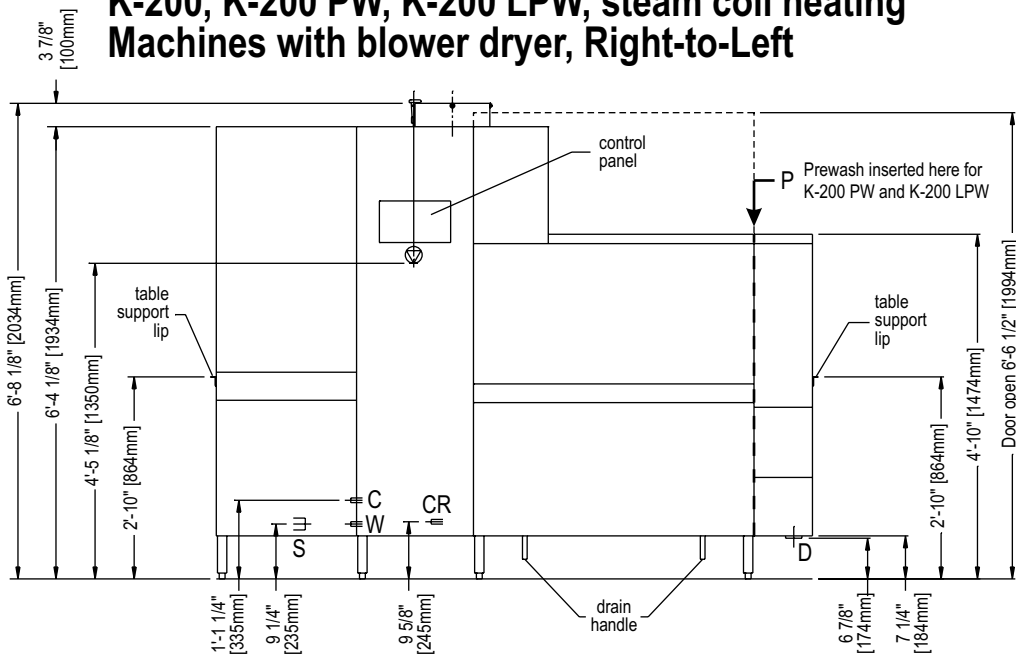

DETAIL VIEW: DRAIN

The machine is equipped with a 2-15/16" (75mm) OD vertical, gravity-fed drain. If possible, the machine drain can simply be positioned directly above a 4" floor drain.

If a floor drain is not in the correct location, or if local codes require a trap, a 3" indirect drain line may be attached using the supplied boot, clamp, and 3" NPT male adapter.

Choose a piping material that:

- Complies with any applicable local and national codes
- Is rated for use with water temperatures up to 180°F/82°C
- Is rated for 3-12 pH to accommodate detergents and rinse aid in the drain water

Direct drain (recommended if possible)

To 3" indirect drain line (supplied by customer)

6 7/8" [174mm]

3 1/2" [90mm]

D

DETAIL VIEW: TABLING

Wall clearances shown are for typical 30" D dishtable. Actual clearances will depend upon table manufacturer and table dimensions.

Feeding and discharge tables to be supplied by others

1" [25mm] max.

2-6" [762mm]

1-6 1/8" [462mm]

5 1/8" [132mm]

3 5/8" [92mm]

Table lip-in height 2'-10" [864mm] A.F.F.

22" [559mm] max.

20-1/2" [521mm] recommended

K-200 Series Technical Specifications

Operating Capacities

	<i>Low</i>	<i>Medium</i>	<i>High</i>
Conveyor speed (ft./min.)	24.12	5.36	6.57
Racks per hour	153	196	240
Dishes per hour	3,825	4,900	6,000
Glasses per hour	5,508	7,056	8,640
Consumption:			
• U.S. gals./hr	84.7	84.7	84.7
• U.S. gals/rack	0.55	0.43	0.35

Conveyor Specifications

Horizontal clearance	1' 8-1/8" (510mm)
Vertical clearance	1' 6" (458mm)

Water Specifications

Minimum water temperatures:

Prewash tank (K-200 PW, LPW only)	140°F (60°C)
Wash tank	160°F (72°C)
Auxiliary rinse	165°F (74°C)
Final rinse	180°F (82°C)

Water requirements:

Incoming water temperature:

• Final rinse connection	50°F (10°C)
• Fill connection	110-140°F (43-60°C)

Initial fill:

- K-200 37.0 gallons (140 liters)
- K-200 PW 52.8 gallons (200 liters)
- K-200 LPW 60.7 gallons (230 liters)
- CSS Top option (all) Add 10.6 gallons (40 liters)

Consumption at 100% capacity ... 84.7 gals. (320.6 liters)/hour

Incoming water line size:

- Final rinse connection
- Fill connection

Flow rate 1.4 gpm (5.3 liters/minute)

Recommended max. water hardness 4-6 grains/gal.

Machine Electrical Specifications

	208 V/60 Hz/3 Ph				230 V/60 Hz/3 Ph				460 V/60 Hz/3 Ph			
	TB1	TB2	TB3	TB4	TB1	TB2	TB3	TB4	TB1	TB2	TB3	TB4
K-200, electric tank heat	18.3A	66.7A	75.0A	--	18.3A	58.2A	65.5A	--	8.4A	29.8A	33.7A	--
K-200 PW, electric tank heat	20.9A	66.7A	75.0A	--	20.9A	58.2A	65.5A	--	9.8A	29.8A	33.7A	--
K-200 LPW, electric tank heat	28.1A	66.7A	75.0A	--	28.1A	58.2A	65.5A	--	12.3A	29.8A	33.7A	--
K-200, steam coil tank heat	18.3A	--	--	--	18.3A	--	--	--	8.4A	--	--	--
K-200 PW, steam coil tank heat	20.9A	--	--	--	20.9A	--	--	--	9.8A	--	--	--
K-200 LPW, steam coil tank heat	28.1A	--	--	--	28.1A	--	--	--	12.3A	--	--	--
CSS Top	+3.9A	--	--	--	+3.9A	--	--	--	+2.3A	--	--	--
Blower dryer, electrically-heated machines ...	--	--	--	16.0A	--	--	--	14.0A	--	--	--	9.2A
Blower dryer, steam coil-heated machines ...	+16.0A	--	--	--	+14.0A	--	--	--	+9.2A	--	--	--

Component Electrical Specifications

Motors:

Wash pump motor	3.0 hp
Prewash pump motor, K-200 PW	0.75 hp
Prewash pump motor, K-200 LPW	3.0 hp
Auxiliary rinse pump motor	0.75 hp
Final rinse pump motor	0.75 hp
Conveyor motor	0.125 hp
Vent motor	0.25 hp
CSS Top pump motor	1.0 hp
Blower dryer motor	0.5 hp

Electric Heating Elements:

Wash tank	24 kW
Auxiliary rinse tank	12 kW
Booster heater	15 kW
Blower dryer heater	3 kW

Steam Specifications (steam-heated units only)

Steam line connection	2" NPT	Steam pressure	10-29 psi (1-2 bars)
Condensate return connection	1" NPT	Consumption	187 lbs./hr. (51 kW)

Equipment Specification: K-200 Series Rack Conveyor - Item No. _____

Item will be a:

- K-200** single tank, rack conveyor dishmachine, consisting of a wash compartment with a 3 hp pump motor, an auxiliary rinse compartment with a 3/4 hp pump motor, and a final rinse compartment with a 3/4 hp pump motor. Total length of the machine (table-to-table) will be 76-3/4" (1950mm). Unit will utilize an internal booster heater to maintain a 180°F/82°C minimum fresh water sanitizing rinse.
- K-200 PW** single tank, rack conveyor dishmachine, consisting of a prewash compartment with a 3/4 hp pump motor, a wash compartment with a 3 hp pump motor, an auxiliary rinse compartment with a 3/4 hp pump motor, and a final rinse compartment with a 3/4 hp pump motor. Total length of the machine (table-to-table) will be 96-1/2" (2450mm). Unit will utilize an internal booster heater to maintain a 180°F/82°C minimum fresh water sanitizing rinse.
- K-200 LPW** single tank, rack conveyor dishmachine, consisting of a prewash compartment with a 3 hp pump motor, a wash compartment with a 3 hp pump motor, an auxiliary rinse compartment with a 3/4 hp pump motor, and a final rinse compartment with a 3/4 hp pump motor. Total length of the machine (table-to-table) will be 108-1/4" (2750mm). Unit will utilize an internal booster heater to maintain a 180°F/82°C minimum fresh water sanitizing rinse.

The dishmachine will be NSF, UL and CUL listed.

Electrical characteristics:

- 208V/60 Hz/3 Ph
- 230V/60 Hz/3 Ph
- 460V/60 Hz/3 Ph

Wash tank temperature will be maintained at a minimum of 160°F/72°C. Tank heating will be accomplished by:

- Thermostatically-controlled electric heating elements
- Thermostatically-controlled stainless steel steam coils

Direction of conveyor travel will be:

- Right-to-Left
- Left-to-Right

Unit will have the following standard features:

- Capacity of 240 racks/hr. and 0.35 gals./rack
- Waste air heat recovery system to reclaim heat generated by the machine, using it as free energy to preheat the incoming rinse water
- Pumped auxiliary rinse zone to supplement the final rinse zone
- Double-wall, insulated construction
- Rack rail-mounted pawl bar drive system for smooth travel at high speeds and an unobstructed wash pattern
- Mike 3 electronic controller for fully automatic operation, variable conveyor speeds and advanced service diagnostics
- Wash arm spray pattern that ensures effective coverage with varying angles and offset spray jets. Slotted, concave wash nozzles and captivated end caps to promote easier cleaning
- Front sloping V-shaped wash tank for complete tank drainage, accessibility, and cleanability
- Low level heater protection
- Powerful 3 Hp wash pump motor is self-draining. Pump motor is internal and vertically installed for easy access and serviceability
- Pump housing and impeller constructed of stainless steel
- Single point drain connection
- Single point ventilation connection
- Large front access doors can be opened with one hand and remain open without latches, aiding machine accessibility and cleanability
- Large, removable stainless pan strainers

Unit will incorporate a Mike 3 electronic control system that allows operation at 3 different conveyor speeds (maximum 6.57 feet/ 2.00m per minute, 240 racks per hour) while consuming an NSF-rated 84.7 gals. (320.6 liters) of water per hour (0.35 gals./ 1.34 liters per rack).

Unit will have the following optional features (check all that apply):

- Blower dryer system incorporating a single blower and 3kW electric heaters for complete drying of all dishes, crockery and silverware
- Hinged front access doors
- External vent fan control
- 1' 11-5/8" (600mm) in length
- 90° loader
- 2' 11-3/8" (900mm) in length
- 90° power unloader
- CSS Top chemical savings system

Innovative Engineering. Obvious Results.



Pumped Auxiliary Rinse and Final Rinse

Two separate rinse zones ensure spotless, sanitized ware and make the most out of fresh incoming water.

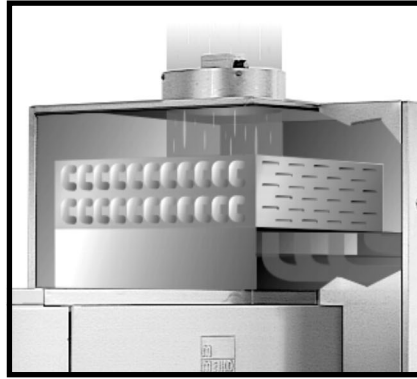

Standard Waste Air Heat Recovery System

Reclaims the waste heat generated by the machine and uses it as free energy to preheat the incoming water supply.

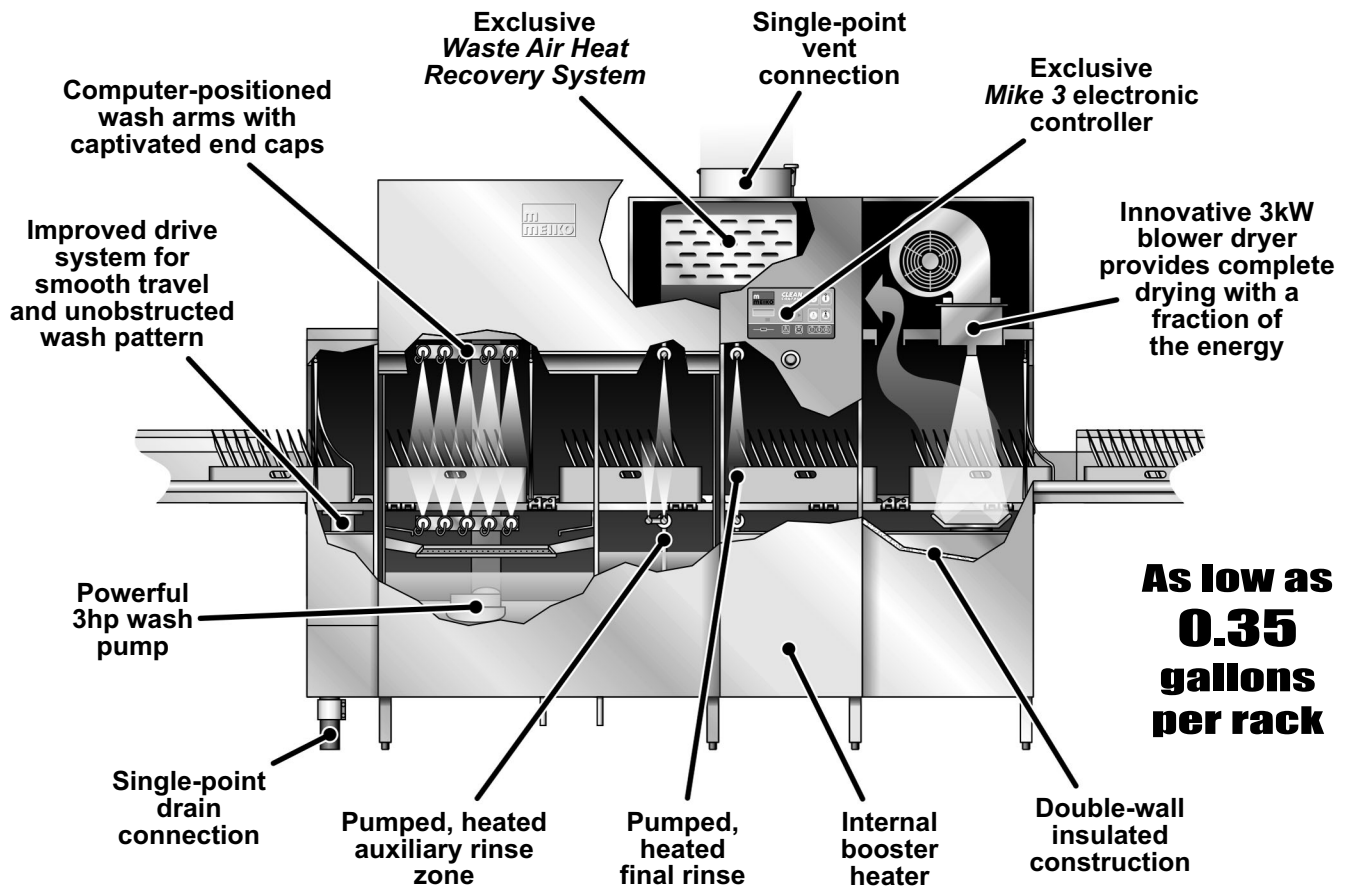

Mike 3 Controller

The next generation of Meiko's award-winning computerized control system, the Mike 3 offers simple, reliable operation and advanced service diagnostics.



Improved drive system

Rack rail mounted pawls ensure an unobstructed wash pattern. Racks are guided smoothly through the machine motions without jerking motions that can dislodge ware.

Note: All specifications are subject to change without notice based on Meiko's dedicated product improvement program.