



18 CU. FT. REACH-IN FREEZER

KCBM180FQY



Dynamic Condenser improves performance in high temperature environments

Automatic Defrost Cooling System provides worry-free performance

1/2 HP Compressor

Mechanical Control

Internal Temperature Display

Adjustable Shelves

Self-Closing Doors with 90-degree stay-open feature

Lock & Key protects the contents of the unit

Heavy Duty Casters

Reversible Door

Interior Lighting



Vinyl Heavy Duty Adjustable Shelves

Shelves that are easy to handle and keep clean.



NSF®-Certified Temperature

Durable and reliable for safety in food storage.



Heavy-Duty, Locking Casters

Keeps unit in place but allows position adjusting.

TECHNICAL SPECIFICATIONS

MODEL	KCBM180FQY
Product Line	Freezer
Capacity (Cu. Ft.)	18
Condenser Type	Dynamic
Automatic Defrost Cooling System	Yes
Compressor Horsepower	1/2
Exterior Finish	Textured Painted Steel
Interior Finish	Smooth Painted Steel
Shelves (Number/Type)	4/Vinyl-Coated Steel
Control	Mechanical
Temperature Display Location	Internal
Temperature Range	-10 to 10°F
Voltage Rating	115V/5A
Run Amps	2.3
Plug Type	NEMA 5-15P
Shipping Weight (Lbs.)	275
Warranty	3 Year/5 Year



18 CU. FT. REACH-IN FREEZER

KCBM180FQY

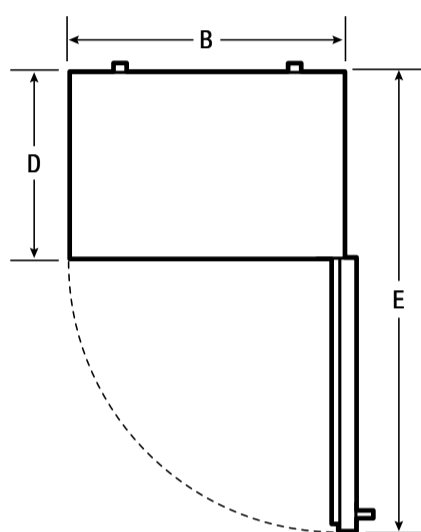

Top View

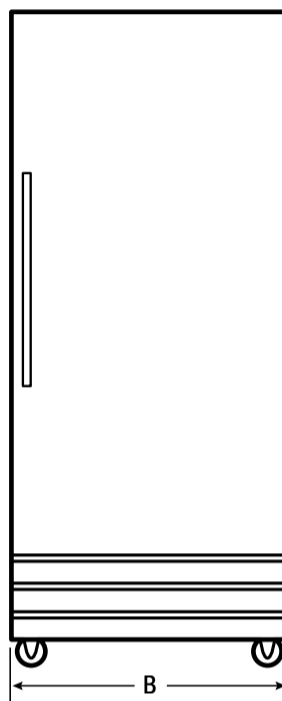

Front View

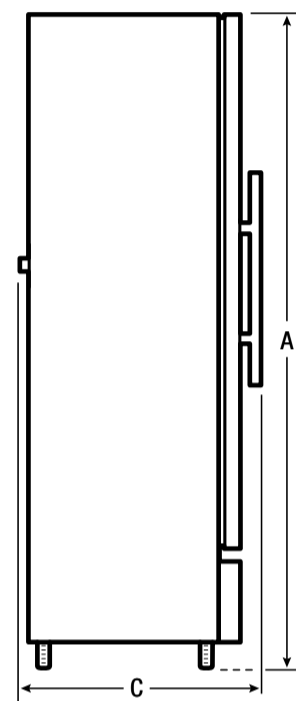

Side View



Plug Type (NEMA)
5-15P

EXTERIOR DIMENSIONS

Height A (Including Casters)	75"
Width B	32"
Overall Depth (Including Door & Handle) C	31-1/8"
Cabinet Depth D	29"
Depth (with Door 90° Open) E	57"

CERTIFICATIONS AND APPROVALS

ENERGY STAR® Qualified	Yes
Safety Certification	CSA
Sanitation Certification	NSF®

ACCESSORIES

Deep shelf (<i>Fits all except top position, white finish</i>)	216384002
Shallow top shelf (<i>Only fits top position, white finish</i>)	216386202
Trivet, white finish	216331802
Shelf support clips (<i>Sold as singles, requires 4 per shelf</i>)	297121900
Pan slide kit (<i>Includes 2 racks/4 clips, holds 8 pans 18" x 26"</i>)	PANRACKKIT
Casters, Front	297206600
Casters, Back	297206500
Caster hardware kit	297256300
Key for lock	216362800
Upright locks	216362700



USA • 10200 David Taylor Drive • Charlotte, NC 28262 • 1-866-738-1640 • kelvinator.com
CANADA • 5855 Terry Fox Way • Mississauga, ON L5V 3E4

KCBM180FQ 08/14

© 2014 Electrolux Home Products, Inc.

High standards of quality at Electrolux Home Products, Inc. mean we are constantly working to improve our products. We reserve the right to change specifications or discontinue models without notice.