



ITEM #: \_\_\_\_\_ QTY: \_\_\_\_\_  
 MODEL #: \_\_\_\_\_  
 PROJECT NAME: \_\_\_\_\_

071917

3601 S. Banker St. Effingham, IL 62401 • P.O. BOX 609 • Ph: (888) 431-2667 • Fax: (800) 433-2667

## **“ST6-GBK” STAINLESS STEEL TOP WORK TABLES**

**16GA TOP AND GALV LEGS AND ADJUSTABLE BRACING**



### **FEATURES:**

- 16 GAUGE STAINLESS STEEL TOP
- TYPE 300 STAINLESS STEEL WITH # 4 POLISH, SATIN FINISH
- TOP IS SOUND DEADENED
- REINFORCED WITH 1”X2” CHANNEL RUNNING ENTIRE LENGTH OF TABLE
- 1-1/2” STALLION EDGE ON FRONT AND REAR WITH SIDE EDGES 90 DEGREE BEND DOWN FOR TABLE LINE-UP
- GALVANIZED BASE WITH ADJUSTABLE BRACING
- SHIPPED KNOCKED-DOWN, EASY - TO - ASSEMBLE
- NSF AND CSA CERTIFIED



ST6-3048GBK

### **CONSTRUCTION:**

- TOP: STAINLESS STEEL TOPS ARE TIG WELDED, EXPOSED WELDS ARE POLISHED TO MATCH ADJACENT SURFACE.

### **MATERIAL:**

- TOP: 16 GAUGE STAINLESS STEEL TYPE 300 STAINLESS STEEL WITH # 4 POLISH, SATIN FINISH
- BRACING: 1-1/4” ROUND O.D. 18 GAUGE GALVANIZED STEEL
- LEGS: 1-5/8” ROUND O.D., 16 GAUGE TUBULAR GALVANIZED STEEL
- GUSSETS: GALVANIZED STEEL
- FEET: 1” ADJUSTABLE GALVANIZED BULLET FEET



ADJUSTABLE BRACING

### **16 GAUGE TOP W/ ADJUSTABLE BRACING**

24” WIDE	QTY	30” WIDE	QTY	36” WIDE	QTY
ST6-2424GBK		ST6-3024GBK		ST6-3624GBK	
ST6-2430GBK		ST6-3030GBK		ST6-3630GBK	
ST6-2436GBK		ST6-3036GBK		ST6-3636GBK	
ST6-2448GBK		ST6-3048GBK		ST6-3648GBK	
ST6-2460GBK		ST6-3060GBK		ST6-3660GBK	
ST6-2472GBK		ST6-3072GBK		ST6-3672GBK	
ST6-2484GBK		ST6-3084GBK		ST6-3684GBK	
ST6-2496GBK		ST6-3096GBK		ST6-3696GBK	
ST6-24108GBK		ST6-30108GBK		ST6-36108GBK	
ST6-24120GBK		ST6-30120GBK		ST6-36120GBK	
ST6-24132GBK		ST6-30132GBK		ST6-36132GBK	
ST6-24144GBK		ST6-30144GBK		ST6-36144GBK	

### **OPTIONAL ACCESSORIES**

DESCRIPTION	MODEL #	QTY
DRAWER		
DRAWER LOCK		
CASTERS		
OVERSHELVES		
SINKS		
POT RACK		

# DETAILED SPECIFICATIONS

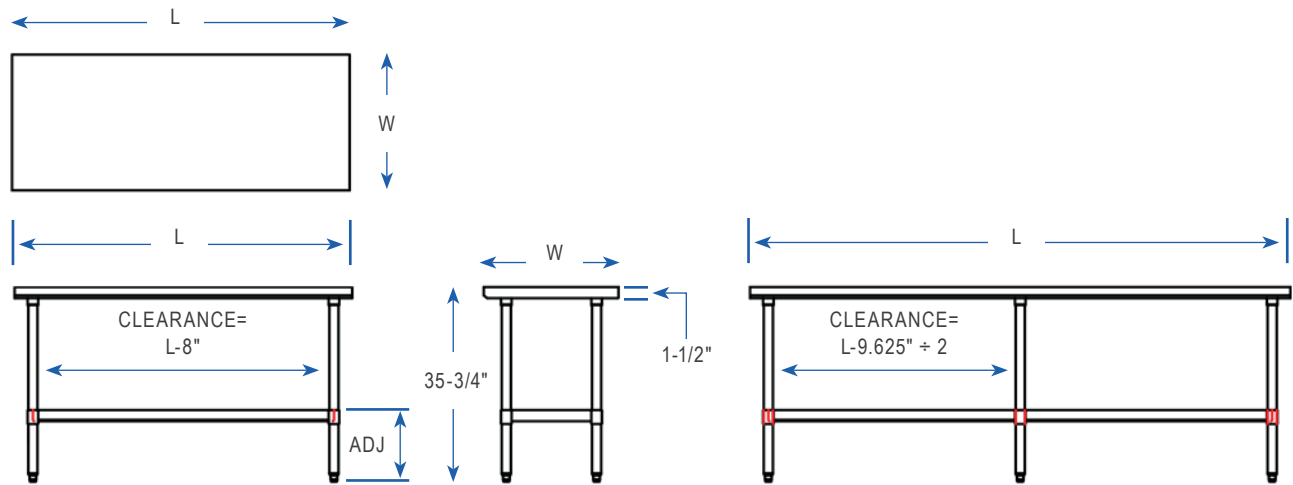

• UNITS 7 FT. AND LARGER ARE FURNISHED WITH SIX LEGS.

## 16 GAUGE TOP W/ ADJUSTABLE BRACING

LENGTH	24" WIDE	WT. (LBS)	30" WIDE	WT. (LBS)	36" WIDE	WT. (LBS)
24"	ST6-2424GBK	28	ST6-3024GBK	35	ST6-3624GBK	41
30"	ST6-2430GBK	39	ST6-3030GBK	45	ST6-3630GBK	51
36"	ST6-2436GBK	50	ST6-3036GBK	55	ST6-3636GBK	70
48"	ST6-2448GBK	60	ST6-3048GBK	67	ST6-3648GBK	75
60"	ST6-2460GBK	70	ST6-3060GBK	79	ST6-3660GBK	88
72"	ST6-2472GBK	80	ST6-3072GBK	91	ST6-3672GBK	101
84"	ST6-2484GBK	95	ST6-3084GBK	107	ST6-3684GBK	119
96"	ST6-2496GBK	109	ST6-3096GBK	122	ST6-3696GBK	136
108"	ST6-24108GBK	119	ST6-30108GBK	134	ST6-36108GBK	150
120"	ST6-24120GBK	129	ST6-30120GBK	146	ST6-36120GBK	163
132"	ST6-24132GBK	129	ST6-30132GBK	141	ST6-36132GBK	152
144"	ST6-24144GBK	144	ST6-30144GBK	155	ST6-36144GBK	166

## MODEL # STRUCTURE

24 = WIDTH OF WORK SURFACE  
6 = 16GA WORK SURFACE  
ST = STAINLESS STEEL TOP

30 = LENGTH OF WORK SURFACE  
GB = GALVANIZED LEGS & BRACING  
K = K.D. W/ ADJUSTABLE BRACING

**ST6-2430GBK**

SOME UNITS SHIP UNASSEMBLED FOR REDUCED SHIPPING COST. ALL DIMENSIONS ARE TYPICAL. TOLERANCE +/- .500"

John Boos & Co. is constantly engaged in a program of improving products and therefore reserves the right to change specifications without prior notice.



Boos  
lock

AQ AutoQuotes

3601 S. Banker St. • Effingham, IL 62401 • PO BOX 609 • quotes@johnboos.com

www.johnboos.com

081417

177