



# HOSHIZAKI

## Parts List

Commercial Series  
Refrigerated Kitchen Equipment

### Models

Undercounter, Worktop, Prep Table

CRM\_27, CRM\_36, CRM\_48, CRM\_60, CRM\_72



[hoshizakiamerica.com](http://hoshizakiamerica.com)

Number: 71335  
Issued: 4-23-2018

## CONTENTS

Auxiliary Codes.....	3
Model Codes .....	13
A. Main Assembly .....	14
CRMR27 and CRMF27 Undercounter, Worktop, and Prep Table .....	14
CRMR36 Undercounter, Worktop, and Prep Table .....	18
CRMR48 and CRMF48 Undercounter, Worktop, and Prep Table .....	21
CRMR60 and CRMF60 Undercounter, Worktop, and Prep Table .....	27
CRMR72 Undercounter, Worktop, and Prep Table .....	33
B. Refrigeration Circuit.....	39
CRMR27 Undercounter, Worktop, and Prep Table .....	39
CRMF27 Undercounter and Worktop .....	41
CRMR36 Undercounter, Worktop, and Prep Table .....	43
CRMR48 Undercounter, Worktop, and Prep Table .....	45
CRMF48 Undercounter and Worktop .....	47
CRMR60 Undercounter, Worktop, and Prep Table .....	49
CRMF60 Undercounter and Worktop .....	51
CRMR72 Undercounter, Worktop, Prep Table .....	53
C. Door-Right Hinged.....	55
D. Door-Left Hinged .....	58
E. Door-Right Glass Door Hinged.....	60
F. Door-Left Glass Door Hinged .....	61
G. Drawer.....	62
H. Accessories & Labels .....	64

## Auxiliary Codes

### CRMR27

A-5 July 2011  
B-5 January 2012  
C-5 January 2013  
C-6 June 2013  
C-7 September 2013  
C-8 December 2013  
D-5 January 2014  
D-6 June 2014  
D-7 July 2014  
E-5 January 2015  
E-6 November 2015  
F-5 January 2016  
F-6 November 2016  
G-5 January 2017  
H-5 January 2018

### CRMR27-GLP01

G-5 July 2017  
H-5 TBD

### CRMR27-01

C-7 September 2013  
D-5 April 2014  
D-7 September 2014  
E-5 February 2015  
E-6 November 2015  
F-5 June 2016  
F-6 November 2016  
G-5 January 2017  
H-5 TBD

### CRMR27-LP

D-5 January 2014  
D-6 June 2014  
D-7 October 2014  
E-5 June 2015  
E-6 November 2015  
F-5 January 2016  
F-6 November 2016  
G-5 January 2017  
H-5 January 2018

### CRMR27-LPC

E-5 September 2015  
F-5 January 2016  
F-6 November 2016  
G-5 January 2017  
H-5 January 2018

### CRMR27-D

C-5 December 2013  
D-5 February 2014  
D-6 August 2014  
E-5 January 2015  
E-6 June 2015  
F-5 January 2016  
F-6 November 2016  
G-5 January 2017  
H-5 January 2018

### CRMR27-W

A-5 December 2011  
B-5 January 2012  
C-5 January 2013  
D-5 May 2014  
D-6 June 2014  
E-5 March 2015  
E-6 December 2015  
F-5 January 2016  
F-6 November 2016  
G-5 January 2017  
H-5 January 2018

### CRMR27-W01

B-5 August 2012  
E-5 February 2015  
E-6 November 2015  
F-6 November 2016  
H-5 TBD

### CRMR27-WD

D-5 February 2014  
D-6 July 2014  
E-5 February 2015  
E-6 September 2015  
F-5 March 2016  
F-6 November 2016  
G-5 February 2017  
H-5 January 2018

### CRMR27-8

B-5 March 2012  
C-5 January 2013  
C-6 June 2013  
C-7 December 2013  
D-5 January 2014  
D-6 June 2014  
D-7 July 2014  
D-8 September 2014  
E-5 January 2015  
E-6 April 2015  
E-7 June 2015  
E-8 November 2015  
F-5 January 2016  
F-6 April 2016  
F-7 August 2016  
F-8 October 2016  
G-5 January 2017  
G-6 June 2017  
H-5 January 2018

### CRMR27-8D

D-5 April 2014  
D-6 July 2014  
D-8 September 2014  
E-6 April 2015  
E-7 October 2015  
E-8 December 2015  
F-5 February 2016  
F-6 May 2016  
F-7 September 2016  
F-8 November 2016  
G-5 February 2017  
G-6 August 2017  
H-5 TBD

## Auxiliary Codes Continued

### CRMR27-12M

B-5 February 2012  
C-5 January 2013  
C-6 May 2013  
C-7 November 2013  
D-5 February 2014  
D-6 June 2014  
D-7 August 2014  
D-8 September 2014  
E-5 January 2015  
E-6 April 2015  
E-7 June 2015  
E-8 November 2015  
F-5 January 2016  
F-6 March 2016  
F-7 August 2016  
F-8 October 2016  
G-5 January 2017  
G-6 June 2017  
H-5 January 2018

### CRMR27-12MD

D-5 February 2014  
D-8 September 2014  
E-6 April 2015  
E-7 June 2015  
E-8 November 2015  
F-5 January 2016  
F-6 March 2016  
F-7 August 2016  
F-8 October 2016  
G-6 July 2017  
H-5 TBD

### CRMF27

A-5 July 2011  
B-5 January 2012  
C-5 January 2013  
C-6 June 2013  
C-7 November 2013  
D-5 January 2014  
D-6 May 2014  
D-7 June 2014  
E-5 January 2015  
E-6 November 2015  
F-5 February 2016  
F-6 July 2016  
F-7 August 2016  
G-5 January 2017  
H-5 January 2018

### CRMF27-GLP01

G-5 July 2017  
H-5 TBD

### CRMF27-01

C-5 October 2013  
D-5 April 2014  
D-7 September 2014  
E-5 February 2015  
E-6 November 2015  
F-5 March 2016  
F-6 July 2016  
F-7 August 2016  
G-5 February 2017  
H-5 TBD

### CRMF27-LP

D-5 January 2014  
D-7 June 2014  
E-5 October 2015  
E-6 November 2015  
F-5 February 2016  
F-6 July 2016  
F-7 September 2016  
G-5 January 2017  
H-5 January 2018

### CRMF27-W

A-5 December 2011  
B-5 January 2012  
C-5 January 2013  
C-6 June 2013  
C-7 December 2013  
D-5 January 2014  
D-6 May 2014  
D-7 June 2014  
E-5 January 2015  
E-6 November 2015  
F-5 January 2016  
F-6 July 2016  
F-7 August 2016  
G-5 January 2017  
H-5 January 2018

### CRMF27-D

D-5 May 2014  
D-7 June 2014  
E-6 October 2015  
F-5 January 2016  
F-6 July 2016  
F-7 October 2016  
G-5 January 2017  
H-5 January 2018

### CRMF27-W01

E-5 April 2015  
F-5 January 2016  
F-6 July 2016  
F-7 August 2016  
G-5 May 2017  
H-5 TBD

### CRMF27-WD

D-5 May 2014  
D-7 October 2014  
E-5 January 2015  
E-6 August 2015  
F-5 January 2016  
F-6 July 2016  
F-7 October 2016  
G-5 March 2017  
H-5 TBD

## **Auxiliary Codes Continued**

### **CRMR36**

F-5 August 2016  
G-5 January 2017  
G-6 May 2017  
H-5 TBD

### **CRMR36-W**

F-5 September 2016  
G-5 February 2017  
G-6 April 2017  
H-5 January 2018

### **CRMR36-10**

F-5 November 2016  
G-5 February 2017  
G-6 April 2017  
G-7 July 2017  
H-5 TBD

### **CRMR36-15M**

F-5 November 2016  
G-5 February 2017  
G-6 April 2017  
G-7 July 2017  
H-5 January 2018

## Auxiliary Codes Continued

### CRMR48

A-5 August 2011  
B-5 January 2012  
C-5 January 2013  
C-6 June 2013  
C-7 October 2013  
C-8 November 2013  
D-5 January 2014  
D-6 October 2014  
E-5 January 2015  
F-5 January 2016  
F-6 March 2016  
F-7 September 2016  
G-5 January 2017  
H-5 January 2018

### CRMR48-GLP01

G-5 July 2017  
H-5 TBD

### CRMR48-01

B-5 August 2012  
D-5 April 2014  
D-6 June 2014  
E-5 February 2015  
F-6 March 2016  
F-7 September 2016  
G-5 February 2017  
H-5 TBD

### CRMR48-D2

G-5 March 2017  
H-5 TBD

### CRMR48-D4

D-5 March 2014  
D-6 September 2014  
E-6 September 2015  
F-5 January 2016  
F-6 March 2016  
F-7 September 2016  
G-5 January 2017  
H-5 January 2018

### CRMR48-W

A-5 December 2011  
B-5 February 2012  
C-5 January 2013  
C-6 June 2013  
C-7 September 2013  
C-8 December 2013  
D-5 February 2014  
D-6 June 2014  
E-5 January 2015  
E-6 July 2015  
F-5 January 2016  
F-6 March 2016  
F-7 September 2016  
G-5 January 2017  
H-5 January 2018

### CRMR48-W01

C-5 February 2013  
E-5 February 2015  
F-6 July 2016  
F-7 October 2016  
G-5 April 2017  
H-5 TBD

### CRMR48-WD2

G-5 June 2017  
H-5 TBD

### CRMR48-WD4

D-5 March 2014  
D-6 September 2014  
E-5 May 2015  
E-6 September 2015  
F-6 June 2016  
F-7 October 2016  
G-5 January 2017  
H-5 January 2018

### CRMR48-8

B-5 March 2012  
C-5 February 2013  
C-6 June 2013  
C-7 November 2013  
D-5 May 2014  
D-7 August 2014  
D-8 October 2014  
E-6 April 2015  
E-7 August 2015  
E-8 November 2015  
F-5 January 2016  
F-6 April 2016  
F-7 August 2016  
F-8 October 2016  
G-5 January 2017  
G-6 July 2017  
H-5 January 2018

### CRMR48-12

B-5 March 2012  
C-5 January 2013  
C-6 May 2013  
C-7 October 2013  
D-5 January 2014  
D-6 June 2014  
D-7 July 2014  
D-8 September 2014  
E-5 January 2015  
E-6 April 2015  
E-7 June 2015  
E-8 November 2015  
F-5 January 2016  
F-6 March 2016  
F-7 August 2016  
F-8 October 2016  
G-5 January 2017  
G-6 June 2017  
H-5 January 2018

## Auxiliary Codes Continued

### CRMR48-12D2

G-5 July 2017  
H-5 January 2018

### CRMR48-12D4

D-5 April 2014  
D-7 August 2014  
D-8 October 2014  
E-6 April 2015  
E-7 August 2015  
E-8 November 2015  
F-6 May 2016  
F-7 August 2016  
F-8 October 2016  
G-5 March 2017  
G-6 September 2017  
H-5 January 2018

### CRMR48-12M

B-5 March 2012  
C-5 February 2013  
C-6 June 2013  
E-5 February 2015  
E-6 April 2015  
E-7 June 2015  
E-8 November 2015  
F-5 January 2016  
F-6 April 2016  
F-7 September 2016  
F-8 October 2016  
G-5 January 2017  
G-6 June 2017  
H-5 TBD

### CRMR48-18M

B-5 February 2012  
C-5 January 2013  
C-6 May 2013  
C-7 November 2013  
D-5 January 2014  
D-6 July 2014  
D-7 August 2014  
D-8 September 2014  
E-5 January 2015  
E-6 April 2015  
E-7 June 2015  
E-8 November 2015  
F-5 January 2016  
F-6 March 2016  
F-7 August 2016  
F-8 October 2016  
G-5 January 2017  
G-6 June 2017  
H-5 January 2018

### CRMR48-18MD2

G-5 March 2017  
G-6 June 2017  
H-5 TBD

### CRMR48-18MD4

D-5 April 2014  
E-5 February 2015  
E-6 May 2015  
E-7 July 2015  
E-8 November 2015  
F-5 January 2016  
F-6 March 2016  
F-7 September 2016  
F-8 October 2016  
G-6 June 2017  
H-5 January 2018

## Auxiliary Codes Continued

### CRMF48

A-5 August 2011  
B-5 January 2012  
B-6 July 2012  
C-5 January 2013  
C-6 June 2013  
C-7 September 2013  
C-8 November 2013  
D-5 January 2014  
D-6 February 2014  
D-7 July 2014  
E-5 February 2015  
F-5 January 2016  
F-6 February 2016  
F-7 August 2016  
G-5 January 2017  
H-5 January 2018

### CRMF48-01

D-5 November 2014  
E-5 March 2015  
F-5 January 2016  
F-6 March 2016  
F-7 August 2016  
G-5 January 2017  
H-5 TBD

### CRMF48-D4

E-5 February 2015  
E-6 October 2015  
F-5 February 2016  
F-6 March 2016  
F-7 August 2016  
G-5 April 2017  
H-5 TBD

### CRMF48-W

A-5 December 2011  
B-5 February 2012  
B-6 July 2012  
C-5 March 2013  
C-6 June 2013  
C-7 November 2013  
D-5 January 2014  
D-6 March 2014  
D-7 July 2014  
D-8 October 2014  
E-5 January 2015  
F-5 January 2016  
F-6 March 2016  
F-7 August 2016  
G-5 January 2017  
H-5 January 2018

### CRMF48-W01

E-5 June 2015  
F-6 April 2016  
F-7 August 2016  
G-5 January 2017  
H-5 TBD

### CRMF48-WD4

E-6 June 2015  
F-6 May 2016  
F-7 August 2016  
G-5 February 2017  
H-5 TBD



## Auxiliary Codes Continued

### CRMR60

B-5 August 2012  
C-5 January 2013  
C-6 July 2013  
D-5 January 2014  
D-6 June 2014  
D-7 August 2014  
D-9 September 2014  
E-5 January 2015  
F-5 February 2016  
F-6 July 2016  
G-5 January 2017  
H-5 January 2018

### CRMR60-01

F-6 December 2016  
G-5 May 2017  
H-5 TBD

### CRMR60-D4

E-5 January 2025  
E-6 June 2015  
F-5 May 2016  
F-6 October 2016  
G-5 January 2017  
H-5 January 2018

### CRMR60-W

B-5 August 2012  
C-5 January 2013  
C-6 October 2013  
C-7 November 2013  
D-5 January 2014  
D-6 June 2014  
D-7 July 2014  
D-9 November 2014  
E-5 February 2015  
F-5 February 2016  
F-6 July 2017  
G-5 January 2017  
H-5 January 2018

### CRMR60-W01

G-5 February 2017  
H-5 TBD

### CRMR60-WD2

G-5 June 2017  
H-5 TBD

### CRMR60-WD4

E-5 April 2015  
F-5 May 2016  
F-6 October 2016  
G-5 April 2017  
H-5 January 2018

### CRMR60-8

C-5 May 2013  
C-6 July 2013  
C-7 September 2013  
E-6 April 2015  
E-7 June 2015  
E-8 September 2015  
E-9 November 2015  
F-6 March 2016  
F-7 August 2016  
G-5 May 2017  
H-5 January 2018

### CRMR60-12

C-5 April 2013  
C-6 June 2013  
D-6 May 2014  
D-7 July 2014  
D-8 August 2014  
D-9 September 2014  
E-5 February 2015  
E-6 April 2015  
E-7 July 2015  
E-8 September 2015  
E-9 November 2015  
F-5 February 2016  
F-6 June 2016  
F-7 August 2016  
F-8 October 2016  
G-5 January 2017  
G-6 July 2017  
H-5 January 2018

### CRMR60-16

C-5 February 2013  
C-6 May 2013  
C-7 September 2013  
D-6 February 2014  
D-7 July 2014  
D-8 August 2014  
D-9 September 2014  
E-5 January 2015  
E-6 April 2015  
E-7 June 2015  
E-8 October 2015  
E-9 November 2015  
F-5 January 2016  
F-6 March 2016  
F-7 August 2016  
F-8 December 2016  
G-5 January 2017  
G-6 June 2017  
H-5 January 2018

### CRMR60-12M

C-5 March 2013  
C-6 May 2013  
C-7 September 2013  
E-6 May 2015  
E-7 June 2015  
E-8 September 2015  
F-6 July 2016  
F-7 August 2016  
F-8 October 2016  
G-5 January 2017  
G-6 June 2017  
H-5 January 2018

## Auxiliary Codes Continued

### CRMR60-18M

C-5 March 2013  
C-6 May 2013  
C-7 September 2013  
C-8 November 2013  
D-6 May 2014  
D-9 September 2014  
E-5 January 2015  
E-6 May 2015  
E-7 June 2015  
E-8 September 2015  
E-9 November 2015  
F-6 March 2016  
F-7 August 2016  
F-8 October 2016  
G-5 February 2017  
G-6 June 2017  
H-5 TBD

### CRMR60-24M

C-5 February 2013  
C-6 May 2013  
C-7 July 2013  
C-8 November 2013  
D-5 January 2014  
D-6 February 2014  
D-7 July 2014  
D-8 August 2014  
D-9 September 2014  
E-5 January 2015  
E-6 May 2015  
E-7 July 2015  
E-8 September 2015  
E-9 November 2015  
F-5 January 2016  
F-6 March 2016  
F-7 August 2016  
F-8 November 2016  
G-5 January 2017  
G-6 June 2017  
H-5 January 2018

### CRMR60-24MD2

G-5 May 2017  
H-5 TBD

### CRMR60-24MD4

E-5 February 2015  
E-6 May 2015  
E-7 July 2015  
E-8 September 2015  
E-9 November 2015  
F-6 May 2016  
F-7 August 2016  
F-8 November 2016  
G-5 January 2017  
G-6 July 2017  
H-5 TBD

### CRMF60

C-5 January 2013  
C-6 September 2013  
C-7 November 2013  
D-6 March 2014  
D-8 September 2014  
E-5 March 2015  
F-5 January 2016  
F-6 September 2016  
G-5 January 2017  
H-5 January 2018

### CRMF60-W

C-5 February 2013  
C-6 September 2013  
C-7 November 2013  
D-5 January 2014  
D-6 April 2014  
D-7 July 2014  
E-5 February 2015  
F-5 January 2016  
F-6 November 2016  
G-5 February 2017  
H-5 January 2018

## Auxiliary Codes Continued

### CRMR72

B-5 July 2012  
C-5 January 2013  
C-6 June 2013  
C-7 December 2013  
D-5 April 2014  
D-6 June 2014  
D-7 July 2014  
E-5 January 2015  
F-5 January 2016  
F-6 November 2016  
G-5 January 2017  
H-5 January 2018

### CRMR72-01

G-5 May 2017  
H-5 TBD

### CRMR72-D6

D-5 December 2014  
E-5 May 2015  
F-5 March 2016  
F-6 October 2016  
G-5 March 2017  
H-5 TBD

### CRMR72-W

B-5 August 2012  
C-5 January 2013  
C-6 June 2013  
D-5 February 2014  
D-6 July 2014  
D-7 August 2014  
E-5 February 2015  
F-5 January 2016  
F-6 November 2016  
G-5 January 2017  
H-5 January 2018

### CRMR72-W01

G-5 May 2017  
H-5 TBD

### CRMR72-WD6

E-5 March 2015  
E-7 June 2015  
F-5 March 2016  
G-5 April 2017  
H-5 TBD

### CRMR72-12

C-5 April 2013  
C-6 June 2013  
C-7 September 2013  
D-8 August 2014  
D-9 October 2014  
E-5 March 2015  
E-6 April 2015  
E-7 June 2015  
E-8 October 2015  
E-9 November 2015  
F-5 January 2016  
F-6 June 2016  
F-7 September 2016  
F-8 November 2016  
G-5 May 2017  
G-6 June 2017  
H-5 TBD

### CRMR72-16

C-5 April 2013  
C-6 June 2013  
C-7 September 2013  
E-7 June 2015  
E-9 November 2015  
F-5 March 2016  
F-6 April 2016  
F-7 August 2016  
F-8 October 2016  
G-5 April 2017  
H-5 January 2018

### CRMR72-18

C-5 February 2013  
C-6 July 2013  
C-7 September 2013  
C-8 November 2013  
D-6 February 2014  
D-7 July 2014  
D-8 August 2014  
D-9 September 2014  
E-5 January 2015  
E-6 April 2015  
E-7 June 2015  
E-8 October 2015  
E-9 November 2015  
F-5 January 2016  
F-6 April 2016  
F-7 August 2016  
F-8 October 2016  
G-5 January 2017  
G-6 June 2017  
H-5 January 2018

### CRMR72-18M

C-5 May 2016  
C-6 July 2013  
C-7 October 2013  
C-8 November 2013  
D-8 September 2014  
E-6 May 2015  
E-7 June 2015  
E-8 October 2015  
F-6 March 2016  
F-7 August 2016  
F-8 October 2016  
G-5 January 2017  
H-5 January 2018

**Auxiliary Codes  
Continued**

**CRMR72-24M**

C-5 May 2013  
C-6 August 2013  
C-7 September 2013  
D-8 August 2014  
E-6 May 2015  
E-8 October 2015  
E-9 November 2015  
F-6 May 2016  
F-7 August 2016  
F-8 December 2016  
G-5 March 2017  
G-6 July 2017  
H-5 TBD

**CRMR72-30M**

C-5 January 2013  
C-6 May 2013  
C-7 July 2013  
C-8 November 2013  
D-5 January 2014  
D-6 February 2014  
D-7 July 2014  
D-8 August 2014  
D-9 November 2014  
E-5 January 2015  
E-6 May 2015  
E-7 June 2015  
E-8 September 2015  
E-9 November 2015  
F-5 January 2016  
F-6 March 2016  
F-7 August 2016  
F-8 October 2016  
G-5 January 2017  
G-6 June 2017  
H-5 January 2018

**CRMR72-30MD4**

G-6 August 2017  
H-5 TBD

**CRMR72-30MD4**

G-6 July 2017  
H-5 January 2018

**CRMR72-30MD6**

E-5 January 2015  
F-5 February 2016  
F-6 April 2016  
F-7 August 2016  
F-8 October 2016  
G-5 February 2017  
G-6 August 2017  
G-7 June 2017  
H-5 February 2018

## Model Codes

The model number code breakdown is as follows: CRMR\_\_ and CRMF\_\_

C – Commercial Series

RM – Rear Mount

R – Refrigerator

F – Freezer

27, 36, 48, 60, and 72 – width

After Dash (-) Nomenclature:

-GLP01 – Glass Door

-01 – Locks

-W – Worktop

-LP – Low Profile Casters

-LPC – Low Profile Stainless Steel Shelf

-D, -D2, -D4, -D6 – Drawers and Drawer/Door Combination

-8, -12, -16, -18, -24, -30 – Prep Table Number of Pans

-8M, -12M, -16M, -18M, -24M, -30M – Mega Top Number of Pans

## Auxiliary Code Breakdown

The auxiliary code is the first two characters in the serial number. The first character indicates the year. Years progress or regress in alphabetical order. The series runs from "A" through "V" and the letters "I" and "O" are skipped. The second character indicates significant part changes within a year. Base is "5" and this number advances for each change. In cases where there is a letter in parentheses, this designates the month. This is the last character in the serial number. The series runs from "(A)" through "(M)" and the letter "(I)" is skipped. This designation is only included when identifying a parts change within an auxiliary code.

## Note About Ordering Parts

Most assemblies cannot be ordered as complete units; parts in the assemblies generally must be ordered separately.

# A. Main Assembly

## CRMR27 and CRMF27 Undercounter, Worktop, and Prep Table

A-5 to H-5

### Undercounter, Worktop, Prep Table Common Parts

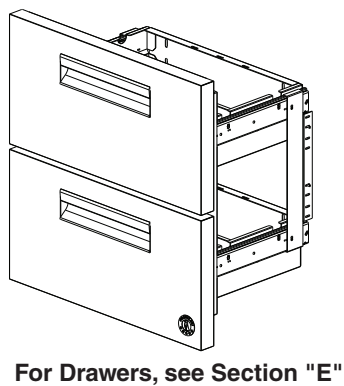
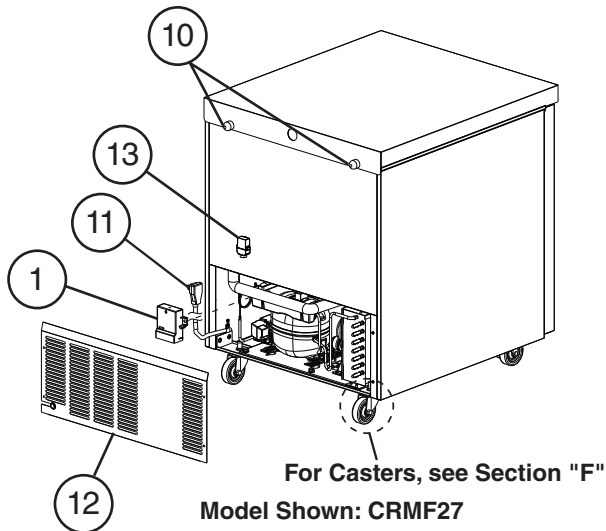
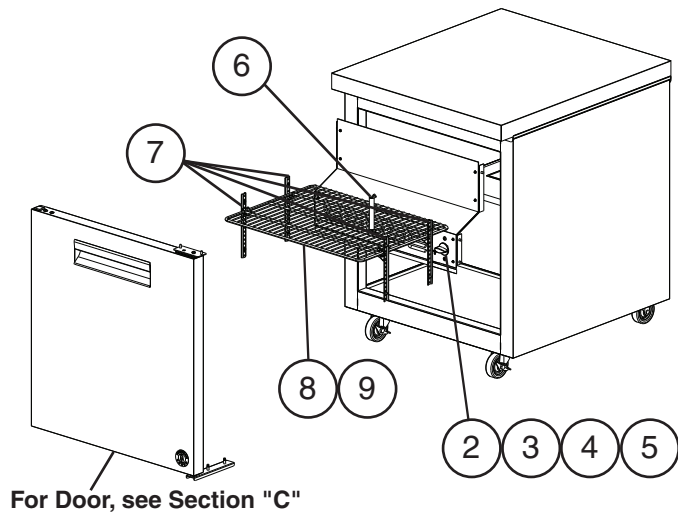

### Prep Table Specific Parts

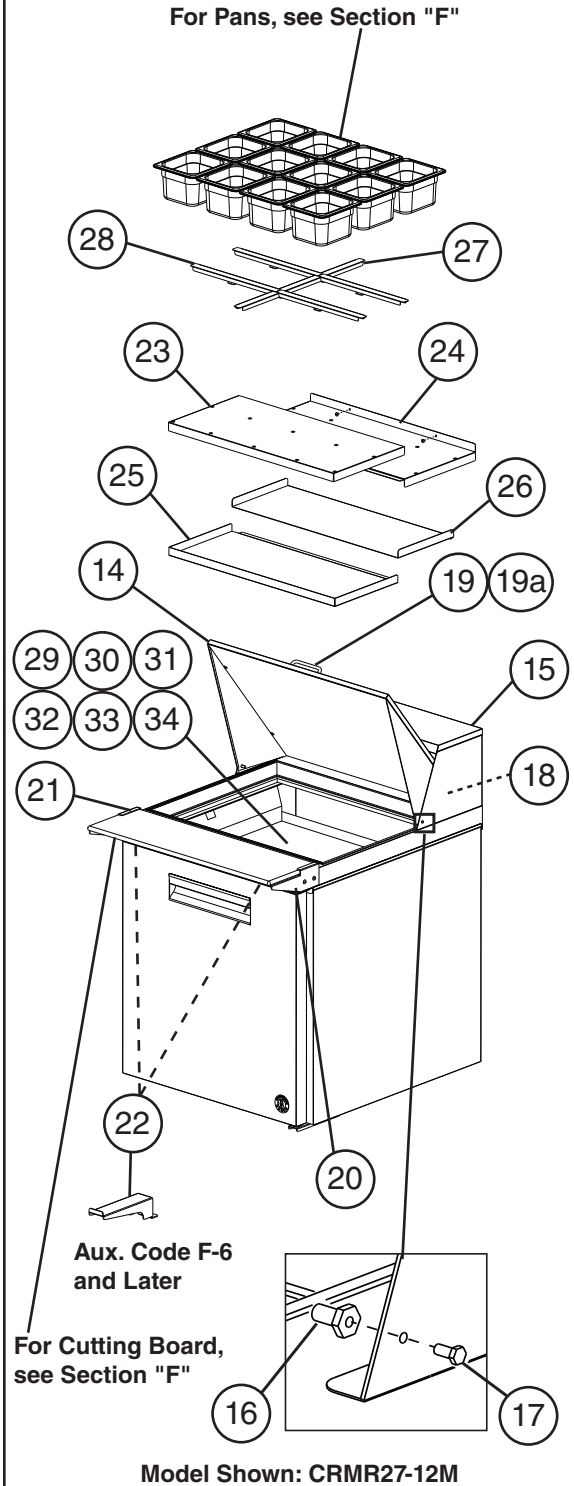

Title: A. Main Assembly Models: CRMR27 and CRMF27 Undercounter, Worktop, and Prep Table																		
Index No.	Description	Material or Model Number	Part Number	Required Number														
				A-5 to C-5	C-6 to D-5	D-6 to D-7	D-8 to E-5	E-6 to E-7	E-8 to F-5 (E)	F-5 (F)	F-6	F-7 to G-5 (A)	G-5 (B)	G-6	H-5			
<b>Common Parts</b>																		
1	Control Module	All UC/WT Refrigerator	4A5959G02									1	1	1	1	1		
		CRMF27-W(-LP)	4A5959G01									1	1	1	1	1	1	
		All Freezers Except CRMF27-W(-LP)											1	1	1	1	1	
	Defrost Timer	All Prep Tables	4A5959G03											1	1	1	1	
		CRMF27-W(-LP)	3A7925-01	1	1	1	1	1	1	1	-							
		All Freezers Except CRMF27-W(-LP)		1	1	1	1	1	1	1	1	1	-					
	All Prep Tables					1	1	1	1	1	-							
2	Cabinet Temperature Control (Spindle)	UC/WT Refrigerator	3A6755-01	1	1	1	1	1	1	1	1	-						
			4A5952-01										1	1	1	1	1	
		CRMF27-W(-LP)	3A6755-02	1	1	1	1	1	1	1	-		-					
			4A5952-01										1	1	1	1	1	1
		All Freezers Except CRMF27-W(-LP)	3A6755-02	1	1	1	1	1	1	1	1	1	-					
			4A5952-01											1	1	1	1	1
	Prep Table	3A6755-07	1	1	1	1	1	1	1	1	1	-						
		4A5952-01											1	1	1	1		
3	Adapter Plate	All UC/WT Refrigerator and Prep Tables	4A5949-01										1	1	-			
		All Freezers											1	1	1	-		
4	Dial Plate		4A5960-01	1	1	1	1	1	1	1	1	1	1	-				
			4A6031-01													1	1	1
5	Dial Knob	All UC/WT Refrigerator	3A6788-01	1	1	1	1	1	1	1	1	-						
			4A5950-01										1	1	1	1	1	
		CRMF27-W(-LP)	3A6788-01	1	1	1	1	1	1	1	-		-					
			4A5950-01										1	1	1	1	1	1
		All Freezers Except CRMF27-W(-LP) and All Prep Tables	3A6788-01	1	1	1	1	1	1	1	1	1	1	-				
			4A5950-01												1	1	1	1
6	Cabinet Thermometer		461083-01	1	1	1	1	1	1	1	1	1	1	1	1	1	1	
7	Side Pilaster		4A5417-01	4	-													
		Note: When using 4A5719-01 on Aux. Code C-6 through E-5, rotate pilaster 180 degrees.	4A5719-01		4	4	4	-										
			4A5854-01					4	4	4	4	4	4	4	4	4	4	4
8	Shelf		3A2830-07	1	1	1	1	1	1	1	1	1	1	1	1	1	1	
9	Shelf Clip		4A5418-01	4	4	4	4	4	4	4	4	4	4	4	4	4	4	
10	Bumper		3A6696-01	2	2	2	2	2	2	2	2	2	2	2	2	2	2	
11	Power Cord		4A2860-01	1	1	1	1	1	1	1	1	1	1	1	1	1	1	
12	Rear Panel		1A2260-01	1	1	1	1	1	1	1	1	1	1	1	1	1	1	
13	Pressure Relief Valve		4A5694-01			1	1	1	1	1	1	1	1	1	1	1	1	

Title: A. Main Assembly Models: CRMR27 and CRMF27 Undercounter, Worktop, and Prep Table																
Index No.	Description	Material or Model Number	Part Number	Required Number												
				A-5 to C-5	C-6 to D-5	D-6 to D-7	D-8 to E-5	E-6 to E-7	E-8 to F-5 (E)	F-5 (F)	F-6	F-7 to G-5 (A)	G-5 (B)	G-6	H-5	
<b>Prep Table Specific Parts</b>																
14	Rail Cover	<b>-8, -8D</b> (includes items 18 through 19a)	3A7326A01	1	1	1	1	1	1	1	1	1	1	-		
		<b>-8, -8D</b> (includes items 16 through 19a)	3A9410A01												1	1
		<b>-12M, -12MD</b> (includes items 18 through 19a)	3A7328A01	1	1	1	1	1	1	1	1	1	1	1	-	
		<b>-12M, -12MD</b> (includes items 16 through 19a)	3A9411A01												1	1
15	Rail Hood	(includes items 16 and 17)	3A7325A01	1	1	1	1	1	1	1	1	1	1	-		
			3A9407A01												1	1
16	Pivot Pin		4A4768-01	2	2	2	2	2	2	2	2	2	2	2	2	
17	Pivot Bolt		4A4769-01	2	2	2	2	2	2	2	2	2	2	2	2	
18	Tree Clip		4A0579-01	2	2	2	2	2	2	2	2	2	2	2	2	
19	Handle		1A3416-01	1	1	1	1	1	1	1	1	1	1	1	1	
19a	Pan Head Screw		7C12I1412	2	2	2	2	2	2	2	2	2	2	2	2	
20	Right Cutting Board Bracket	<b>-8, -8D</b>	4A5496-02	1	1	1	1	-								
			3A8653-02					1	1	1	-					
			3A8971-02								1	1	1	1	1	
		<b>-12M, -12MD</b>	1000000393	1	1	1	1	-								
			SP-5198					1	1	1	-					
			3A8971-02								1	1	1	1	1	
21	Left Cutting Board Bracket	<b>-8, -8D</b>	4A5496-01	1	1	1	1	-								
			3A8653-01					1	1	1	-					
			3A8971-01								1	1	1	1	1	
		<b>-12M, -12MD</b>	1000000392	1	1	1	1	-								
			SP-5198					1	1	1	-					
			3A8971-01								1	1	1	1	1	
22	Center Cutting Board Bracket	<b>-8, -8D</b>	4A5905-01								1	1	1	1	1	
		<b>12M, -12MD</b> (Qty varies by Auxiliary Code)	4A5898-01									2	2	2	2	2
23	Upper Front Air Distribution Table Panel	<b>-8, -8D, -12M, -12MD</b>	2A6920-01	1	1	-										
24	Upper Rear Air Distribution Table Panel		2A6919-01	1	1	-										
25	Lower Front Air Distribution Table Panel		2A6922-01	1	1	-										
26	Lower Rear Air Distribution Table Panel		2A6921-01	1	1	-										



Title: A. Main Assembly Models: CRMR27 and CRMF27 Undercounter, Worktop, and Prep Table															
Index No.	Description	Material or Model Number	Part Number	Required Number											
				A-5 to C-5	C-6 to D-5	D-6 to D-7	D-8 to E-5	E-6 to E-7	E-8 to F-5 (E)	F-5 (F)	F-6	F-7 to G-5 (A)	G-5 (B)	G-6	H-5
27	Rail Divider (front-to-back)	-8, -8D (HS-5187)	3A8903-01	E-7 and earlier must order items 26 and 27						1	1	1	1	1	1
		-12M, -12MD (HS-5184)	3A8855-01		1	1	1	1	1	1	1				
28	Rail Divider (side-to-side)	-8, -8D (HS-5185)	3A8856-01		2	2	2	2	2	2	2	2			
		-12M, -12MD (HS-5185)			4	4	4	4	4	4	4				
29	Spill Guard (includes items 30 through 34)	-8, -8D (HS-5220)	1A4219-01											1	
		-12M, -12MD (HS-5207)	1A4115-01											1	
30	Handle		4A4518-01											1	
31	Handle Bracket		4A5297-01											1	
32	Pan Head Screw	8x32	7C12I0812											2	
33	Split Lock Washer		7L22I0832											2	
34	Flat Washer		7W22I0832											2	

**A. Main Assembly**  
**CRMR36 Undercounter, Worktop, and Prep Table**  
 F-5 to H-5

**Undercounter, Worktop, Prep Table**  
**Common Parts**

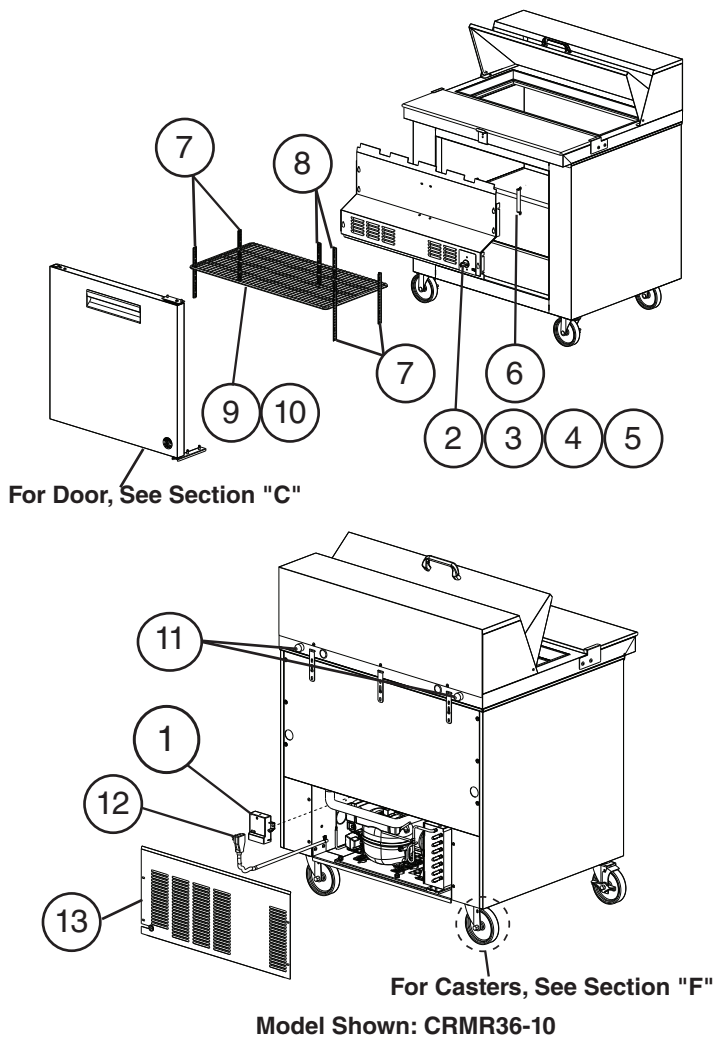

**Prep Table**  
**Specific Parts**

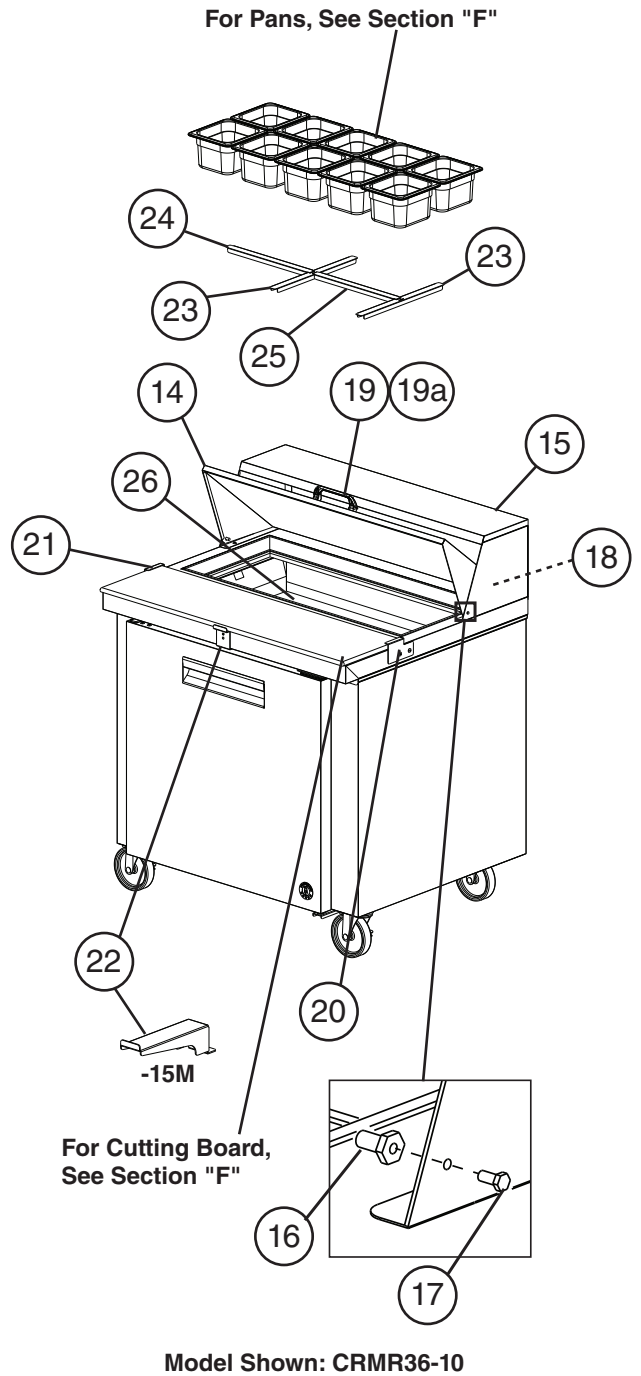

<b>Title: A. Main Assembly    Models: CRMR36 Undercounter, Worktop, and Prep Table</b>												
Index No.	Description	Material or Model Number	Part Number	Required Number								
				F-5 to G-6	G-7	H-5						
<b>Common Parts</b>												
1	Control Module	<b>UC/WT</b>	4A5959G02	1	1	1						
		<b>All Prep Table</b>	4A5959G03	1	1	1						
2	Cabinet Temperature Control (Spindle)		4A5952-01	1	1	1						
3	Adapter Plate		4A5949-01	1	1	1						
4	Dial Plate		4A5960-01	1	1	1						
5	Dial Knob		4A5950-01	1	1	1						
6	Cabinet Thermometer		461083-01	1	1	1						
7	Side Pilaster		4A5719-01	4	4	4						
8	Center Pilaster		4A5417-01	2	2	2						
9	Shelf		3A6876-05	1	1	1						
10	Shelf Clip		4A5418-01	6	6	6						
11	Bumper		3A6696-01	2	2	2						
12	Power Cord		4A2860-01	1	1	1						
13	Rear Panel		1A2836-01	1	1	1						
<b>Prep Table Specific Parts</b>												
14	Rail Cover (includes items 18 through 19a)	<b>-10</b> (includes items 18 through 19a)	3A9154A01	1	-							
		<b>-10</b> (includes items 16 through 19a)	3A9408A01		1	1						
		<b>-15M</b> (includes items 18 through 19a)	3A9155A01	1	-							
		<b>-15M</b> (includes items 16 and 19a)	3A9409A01		1	1						
15	Rail Hood	(includes items 16 and 17)	3A9153A01	1	-							
			3A9406A01		1	1						
16	Pivot Pin		4A4768-01	2	2	2						
17	Pivot Bolt		4A4769-01	2	2	2						
18	Tree Clip		4A0579-01	2	2	2						
19	Handle		1A3416-01	1	1	1						
19a	Pan Head Screw		7C1211412	2	2	2						

<b>Title: A. Main Assembly      Models: CRMR36 Undercounter, Worktop, and Prep Table</b>												
Index No.	Description	Material or Model Number	Part Number	Required Number								
				F-5 to G-6	G-7	H-5						
20	Right Cutting Board Bracket	<b>-10, -15M</b>	3A8971-02	1	1	1						
21	Left Cutting Board Bracket	<b>-10, -15M</b>	3A8971-01	1	1	1						
22	Center Cutting Board Bracket	<b>-10</b>	4A5905-01	1	1	1						
		<b>-15M</b>	4A5898-01	3	3	3						
23	Rail Divider (front-to-back)	<b>-10</b> (HS-5187)	3A8903-01	2	2	2						
		<b>-15M</b> (HS-5184)	3A8855-01	2	2	2						
24	Rail Divider (side-to-side outer)	<b>-10</b> (HS-5185)	3A8856-01	1	1	1						
		<b>-15M</b> (HS-5185)		2	2	2						
25	Rail Divider (side-to-side center)	<b>-10</b> (HS-5186)	3A8857-01	1	1	1						
		<b>-15M</b> (HS-5186)		2	2	2						
26	Spill Guard	<b>-10</b> (HS-5221)	1A4219-02			1						
		<b>-15M</b> (HS-5222)	1A4219-03			1						

# A. Main Assembly

## CRMR48 and CRMF48 Undercounter, Worktop, and Prep Table

A-5 to H-5

### Undercounter, Worktop, Prep Table

#### Common Parts

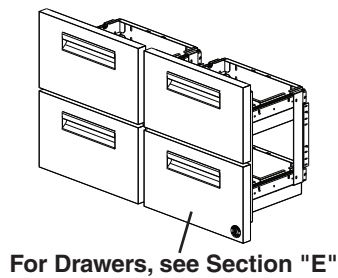
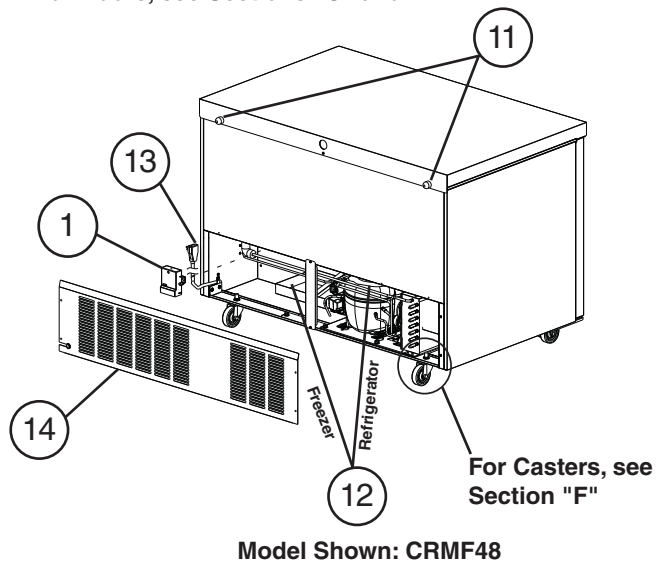
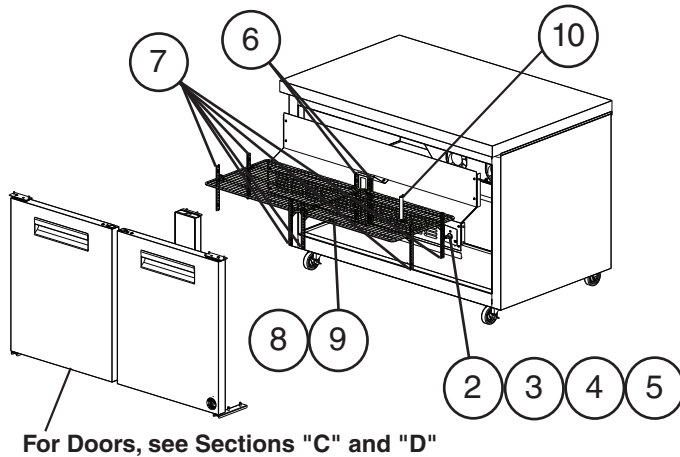

### Prep Table Specific Parts

For Pans, see Section "F"

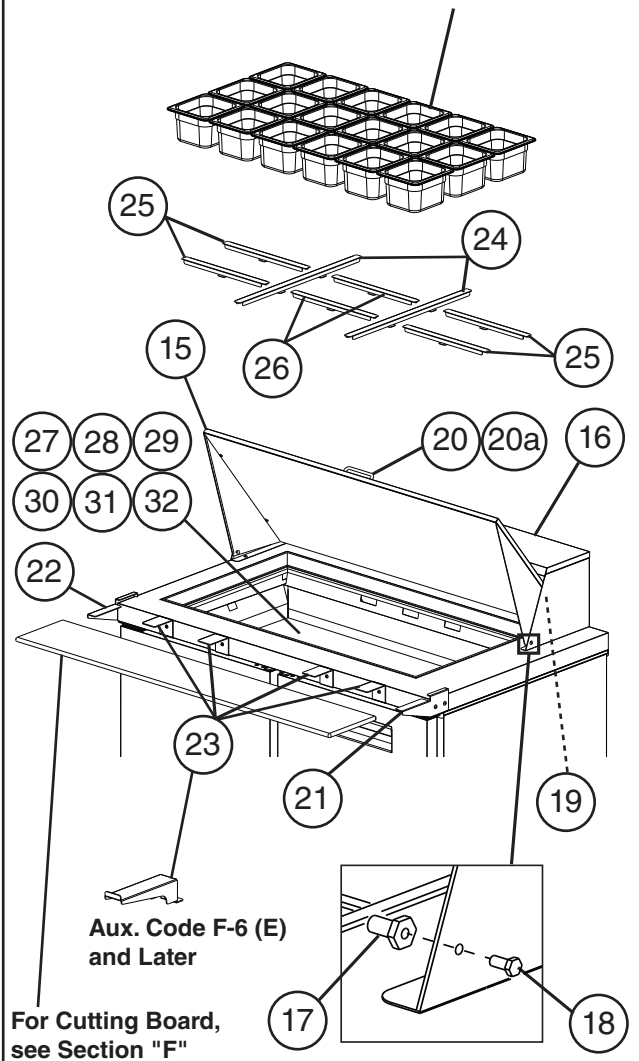

<b>Title: A. Main Assembly Models: CRMR48 and CRMF48 Undercounter, Worktop, and Prep Table</b>																
Index No.	Description	Material or Model Number	Part Number	Required Number												
				A-5 to C-5 (C)	C-5 (D) to E-5 (B)	E-5 (C)	E-6 to E-7	E-8 to F-5	F-6 to F-6 (E)	F-6 (F)	F-6 (G)	F-6 (H)	F-7 to G-5 (E)	G-5 (F) to G-6	H-5	
<b>Common Parts</b>																
1	Control Module	CRMR48(-W)	4A5959G02										1	1	1	1
		All UC/WT Refrigerators Except CRMR48(-W)												1	1	1
		CRMF48(-W)	4A5959G01								1	1	1	1	1	1
		All Freezers Except CRMF48(-W)									1	1	1	1	1	1
		All Prep Tables	4A5959G03											1	1	1
	Defrost Timer	CRMF48(-W)	3A7925-01	1	1	1	1	1	1	-						
		All Freezers Except CRMF48(-W)		1	1	1	1	1	1	1	-					
All Prep Tables			1	1	1	1	1	1	1	1	1	-				
2	Cabinet Temperature Control (Spindle) (SP-5241 includes item 1. Control Module)	CRMR48(-W)	3A6755-01	1	1	1	1	1	1	1	1	-				
			4A5952-01										1	1	1	1
		All UC/WT Refrigerators Except CRMR48(-W)	3A6755-01	1	1	1	1	1	1	1	1	1	-			
			4A5952-01											1	1	1
		CRMF48(-W)	SP-5241	1	1	1	1	1	1	-						
			4A5952-01								1	1	1	1	1	1
		All Freezers Except CRMF48(-W)	SP-5241	1	1	1	1	1	1	1	-					
			4A5952-01									1	1	1	1	1
All Prep Tables	3A6755-07	1	1	1	1	1	1	1	1	1	1	-				
	4A5952-01											1	1	1		
3	Adapter Plate	CRMR48(-W)	4A5949-01										1	1	1	1
		All UC/WT Refrigerators Except CRMR48(-W)											1	1	1	
		CRMF48(-W)									1	1	1	1	1	
		All Freezers Except CRMF48(-W)									1	1	1	1	1	
		All Prep Tables												1	1	1

Title: A. Main Assembly Models: CRMR48 and CRMF48 Undercounter, Worktop, and Prep Table															
Index No.	Description	Material or Model Number	Part Number	Required Number											
				A-5 to C-5 (C)	C-5 (D) to E-5 (B)	E-5 (C)	E-6 to E-7	E-8 to F-5	F-6 to F-6 (E)	F-6 (F)	F-6 (G)	F-6 (H)	F-7 to G-5 (E)	G-5 (F) to G-6	H-5
4	Dial Plate Label	<b>CRMR48(-W)</b>	3A6787-01	1	1	1	1	1	1	1	1	1	-		
			4A5960-01									1	1	1	1
		<b>All UC/WT Refrigerators Except CRMR48(-W)</b>	3A6787-01	1	1	1	1	1	1	1	1	1	1	-	
			4A5960-01										1	1	1
		<b>CRMF48(-W)</b>	3A6787-01	1	1	1	1	1	1	-					
			4A5960-01							1	1	1	1	1	1
		<b>All Freezers Except CRMF48(-W)</b>	3A6787-01	1	1	1	1	1	1	1	1	-			
			4A5960-01								1	1	1	1	1
<b>All Prep Tables</b>	3A6787-01	1	1	1	1	1	1	1	1	1	1	-			
	4A5960-01										1	1	1		
5	Dial Knob	<b>CRMR48(-W)</b>	3A6788-01	1	1	1	1	1	1	1	1	-			
			4A5950-01									1	1	1	
		<b>All UC/WT Refrigerators Except CRMR48(-W)</b>	3A6788-01	1	1	1	1	1	1	1	1	1	-		
			4A5950-01										1	1	1
		<b>CRMF48(-W)</b>	3A6788-01	1	1	1	1	1	1	-					
			4A5950-01							1	1	1	1	1	1
		<b>All Freezers Except CRMF48(-W)</b>	3A6788-01	1	1	1	1	1	1	1	1	-			
			4A5950-01								1	1	1	1	1
<b>All Prep Tables</b>	3A6787-01	1	1	1	1	1	1	1	1	1	1	-			
	4A5960-01										1	1	1		
6	All Pilasters		4A5417-01	8	-										
	Center Back Pilasters			2	2	2	2	2	2	2	2	2	2		
7	Sides and Front Pilaster	<b>All UC/WT/ Prep Tables</b>	4A5524-01		6	-									
			4A5719-01			6	6	6	6	6	6	6	6	6	
		<b>Door/Drawer</b>									4	4	4	4	
8	Shelf	<b>All UC/WT/ Prep Tables</b>	3A2830-08	2	2	2	2	2	2	2	2	2	2		
			<b>Door/Drawer</b>									1	1	1	1
9	Shelf Clip	<b>All UC/WT/ Prep Tables</b>	4A5418-01	8	8	8	8	8	8	8	8	8	8		
			<b>Door/Drawer</b>									4	4	4	4
10	Cabinet Thermometer		461083-01	1	1	1	1	1	1	1	1	1	1		
11	Bumpers		3A6696-01	2	2	2	2	2	2	2	2	2	2		
12	Condensate Pan	<b>All UC/WT/ Prep Tables</b>	3A6758-01	1	1	1	1	1	1	1	1	1	1		
			<b>All Freezers</b>	2A7170-03	1	-									
			1A3373-01		1	1	1	1	1	1	1	1	1	1	
13	Power Cord		4A2860-01	1	1	1	1	1	1	1	1	1	1		
14	Rear Panel	<b>All UC/WT/ Prep Tables</b>	1A2261-01	1	1	1	1	1	1	1	1	1	1		
			<b>All Freezers</b>	1A2340-01	1	1	1	1	1	1	1	1	1	1	

Title: A. Main Assembly Models: CRMR48 and CRMF48 Undercounter, Worktop, and Prep Table																
Index No.	Description	Material or Model Number	Part Number	Required Number											H-5	
				A-5 to C-5 (C)	C-5 (D) to E-5 (B)	E-5 (C)	E-6 to E-7	E-8 to F-5	F-6 to F-6 (E)	F-6 (F)	F-6 (G)	F-6 (H)	F-7 to G-5 (E)	G-5 (F) to G-6		
<b>Prep Table Specific Parts</b>																
15	Rail Cover Assembly	-8 (includes items 19 through 20a)	3A7330A01	1	1	1	1	1	1	1	1	1	1	-		
		-8 (includes items 17 through 20a)	3A9405A01												1	1
		-12, -12D2, -12D4 (includes items 19 through 20a)	3A7331A01	1	1	1	1	1	1	1	1	1	1	1	-	
		-12, -12D2, -12D4 (includes items 17 through 20a)	3A9398A01												1	1
		-12M (includes items 19 through 20a)	3A7332A01	1	1	1	1	1	1	1	1	1	1	1	-	
		-12M (includes items 17 through 20a)	3A9402A01												1	1
		-18M, -18MD2, -18MD4 (includes items 19 through 20a)	3A7333A01	1	1	1	1	1	1	1	1	1	1	1	-	
		-18M, -18MD2, -18MD4 (includes items 17 through 20a)	3A9399A01												1	1
16	Rail Hood	-8 (includes items 17 and 18)	3A7327A01	1	1	1	1	1	1	1	1	1	1	-		
		-8	3A9404A01											1	1	
		-12M (includes items 17 and 18)	3A7327A01	1	1	1	1	1	1	1	1	1	1	-		
		-12M	3A9403A01											1	1	
		-12, -12D2, -12D4 (includes items 17 and 18)	3A7329A01	1	1	1	1	1	1	1	1	1	1	-		
		-12, -12D2, -12D4	3A9394A01											1	1	
		-18M, -18MD2, -18MD4 (includes items 17 and 18)	3A7329A01	1	1	1	1	1	1	1	1	1	1	-		
		-18M, -18MD2, -18MD4	3A9395A01											1	1	
17	Pivot Pin		4A4768-01	2	2	2	2	2	2	2	2	2	2	2	2	
18	Pivot Bolt		4A4769-01	2	2	2	2	2	2	2	2	2	2	2	2	



Title: A. Main Assembly Models: CRMR48 and CRMF48 Undercounter, Worktop, and Prep Table															
Index No.	Description	Material or Model Number	Part Number	Required Number											
				A-5 to C-5 (C)	C-5 (D) to E-5 (B)	E-5 (C)	E-6 to E-7	E-8 to F-5	F-6 to F-6 (E)	F-6 (F)	F-6 (G)	F-6 (H)	F-7 to G-5 (E)	G-5 (F) to G-6	H-5
19	Tree Clip		4A0579-01	2	2	2	2	2	2	2	2	2	2	2	2
20	Handle		1A3416-01	1	1	1	1	1	1	1	1	1	1	1	1
20a	Pan Head Screw		7C12I1412	2	2	2	2	2	2	2	2	2	2	2	2
21	Right Cutting Board Bracket	<b>-8, -12, -12D2, -12D4</b>	4A5496-01	1	1	1	-								
			3A8653-02				1	1	-						
			3A8971-02						1	1	1	1	1	1	1
		<b>-12M, -18M, -18MD2, -18MD4</b>	1000000393	1	1	1	-								
			SP-5199				1	1	-						
			3A8971-02						1	1	1	1	1	1	1
22	Left Cutting Board Bracket	<b>-8, -12, -12D2, -12D4</b>	4A5496-02	1	1	1	-								
			3A8653-01				1	1	-						
			3A8971-01						1	1	1	1	1	1	
		<b>-12M, -18M, -18MD2, -18MD4</b>	1000000392	1	1	1	-								
			SP-5199				1	1	-						
			3A8971-01						1	1	1	1	1	1	
23	Center Cutting Board Bracket	<b>-8, -12, -12D2, -12D4</b>	4A5905-01						2	2	2	2	2	2	
			1000000394	2	2	2	2	2	-						
			4A5898-01						4	4	4	4	4	4	
24	Rail Divider A (front-to-back)	<b>-8 (HS-5188)</b>	3A8904-01						1	1	1	1	1	1	
								2	2	2	2	2	2		
		<b>-12, -12D2, 12D4 (HS-5188)</b>	3A8855-01						1	1	1	1	1	1	
									2	2	2	2	2	2	
25	Rail Divider B (side-to-side)	<b>-8 (HS-5189)</b>	3A8905-01	E-7 and earlier must order items 24, 25, and if applicable, 26					1	1	1	1	1	1	
									2	2	2	2	2	2	
		<b>-12, -12D2, -12D4 (HS-5189)</b>	3A8856-01							4	4	4	4	4	4
									4	4	4	4	4	4	
	(outer side-to-side)	<b>-18M -18MD2, -18MD4 (HS-5185)</b>							4	4	4	4	4	4	
26	Rail Divider C (center side-to-side)	<b>-18M, -18MD2, -18MD4 (HS-5186)</b>	3A8857-01						2	2	2	2	2		

Title: A. Main Assembly Models: CRMR48 and CRMF48 Undercounter, Worktop, and Prep Table															
Index No.	Description	Material or Model Number	Part Number	Required Number											H-5
				A-5 to C-5 (C)	C-5 (D) to E-5 (B)	E-5 (C)	E-6 to E-7	E-8 to F-5	F-6 to F-6 (E)	F-6 (F)	F-6 (G)	F-6 (H)	F-7 to G-5 (E)	G-5 (F) to G-6	
27	Spill Guard (includes items 28, through 32)	-8 (HS-5223)	1A4221-01												1
		-12, -12D2, -12D4 (HS-5226)	1A4221-03												1
		-12M (HS-5207)	1A4115-01												1
		-18M, -18MD2, -18MD4 (HS-5213)	1A4154-01												1
28	Handle	-12M	4A4518-01											1	
		-18M, -18MD2, -18MD4												2	
29	Handle Bracket	-12M	4A5297-01											1	
		-18M, -18MD2, -18MD4												2	
30	Pan Head Screw	-12M	7C12I0812											2	
		-18M, -18MD2, -18MD4												4	
31	Split Lock Washer	-12M	7L22I0832											2	
		-18M, -18MD2, -18MD4												4	
32	Flat Washer	-12M	7W22I0832											2	
		-18M, -18MD2, -18MD4												4	

# A. Main Assembly

## CRMR60 and CRMF60 Undercounter, Worktop, and Prep Table

B-5 to H-5

### Undercounter, Worktop, Prep Table

#### Common Parts

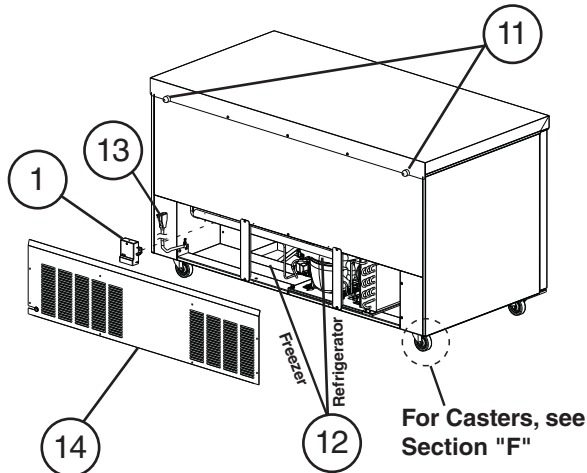
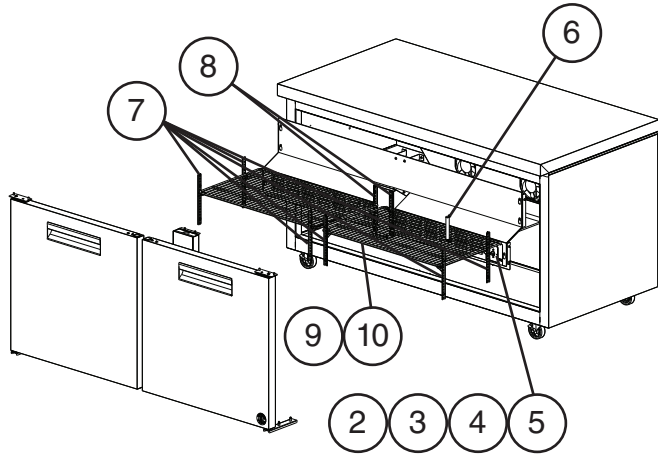

Model Shown: CRMF60

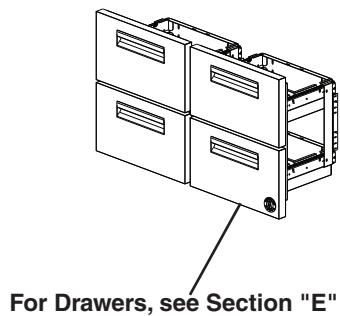

For Drawers, see Section "E"

### Prep Table Specific Parts

For Pans, see Section "F"

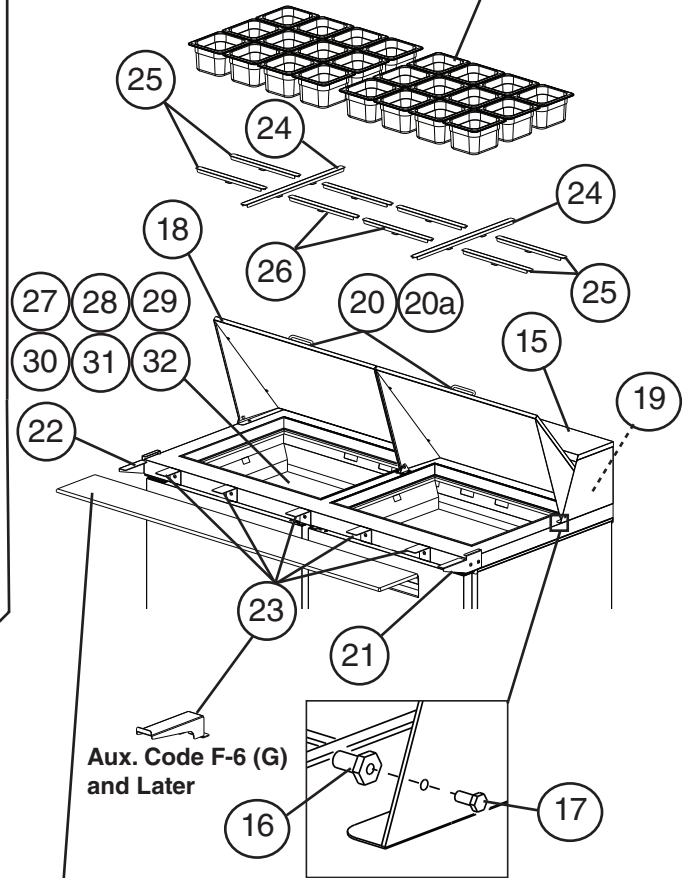

Aux. Code F-6 (G)  
and Later

Model Shown: CRMR60-24M

For Cutting Board,  
see Section "F"

Title: A. Main Assembly Models: CRMR60 and CRMF60 Undercounter, Worktop, and Prep Table																
Index No.	Description	Material or Model Number	Part Number	Required Number												
				B-5 to D-5	D-6 to D-7	D-8 to E-5 (B)	E-5 (C)	E-6 to E-8	E-9 to F-5	F-6 to F-6 (F)	F-6 (G)	F-7 to G-5 (A)	G-5 (B)	G-6	H-5	
<b>Common Parts</b>																
1	Control Module	<b>All UC/WT Refrigerators</b>	4A5959G02								1	1	1	1	1	1
		<b>All Freezers</b>	4A5959G01								1	1	1	1	1	1
		<b>All Prep Tables</b>	4A5959G03										1	1	1	1
	Defrost Timer	<b>All Freezers</b>	3A7925-01	1	1	1	1	1	1	-						
		<b>All Prep Tables</b>		1	1	1	1	1	1	1	1	-				
2	Cabinet Temperature Control (Spindle)	<b>All UC/WT Refrigerators</b>	3A6755-03	1	1	1	1	1	1	-						
			4A5952-01							1	1	1	1	1	1	
		<b>All UC/WT Freezers</b>	3A6755-04	1	1	1	1	1	1	-						
			4A5952-01								1	1	1	1	1	1
		<b>All Prep Tables</b>	3A6755-07	1	1	1	1	1	1	1	1	1	-			
		4A5952-01									1	1	1	1	1	
3	Adapter Plate		4A5949-01							1	1	1	1	1	1	
4	Dial Plate		4A5960-01	1	1	1	1	1	1	1	1	1	1	1	1	
5	Dial Knob	<b>All UC/WT Refrigerators and Freezers</b>	3A6788-01	1	1	1	1	1	1	-						
			4A5950-01							1	1	1	1	1	1	
		<b>Prep Table</b>	3A6788-01	1	1	1	1	1	1	1	1	-				
			4A5950-01									1	1	1	1	1
6	Cabinet Thermometer		461083-01	1	1	1	1	1	1	1	1	1	1	1	1	
7	Side and Front Pilaster		4A5524-01	6	6	6	-									
			4A5719-01				6	6	6	6	6	6	6	6	6	
		<b>Door/Drawer</b>										4	4	4	4	
8	Rear Pilaster		4A5417-01	2	2	2	2	2	2	2	2	2	2	2	2	
9	Shelf		3A2830-09	2	2	2	2	2	2	2	2	2	2	2	2	
		<b>Door/Drawer</b>										1	1	1	1	
10	Shelf Clip		4A5418-01	8	8	8	8	8	8	8	8	8	8	8	8	
		<b>Door/Drawer</b>										4	4	4	4	
11	Bumpers		3A6696-01	2	2	2	2	2	2	2	2	2	2	2	2	
12	Condensate Pan	<b>Refrigerator</b>	3A6758-01	1	1	1	1	1	1	1	1	1	1	1	1	
		<b>Freezer</b>	2A7170-03	1	1	-										
			1A3373-01			1	1	1	1	1	1	1	1	1	1	1
13	Power Cord		4A2860-01	1	1	1	1	1	1	1	1	1	1	1	1	
14	Rear Panel	<b>All UC/WT/</b>	1A2542-01	1	1	1	1	1	1	1	1	1	1	1	1	
		<b>All Freezers/ Prep Tables</b>	1A2692-01	1	1	1	1	1	1	1	1	1	1	1	1	1

Title: A. Main Assembly Models: CRMR60 and CRMF60 Undercounter, Worktop, and Prep Table																
Index No.	Description	Material or Model Number	Part Number	Required Number											G-6	H-5
				B-5 to D-5	D-6 to D-7	D-8 to E-5 (B)	E-5 (C)	E-6 to E-8	E-9 to F-5	F-6 to F-6 (F)	F-6 (G)	F-7 to G-5 (A)	G-5 (B)			
<b>Prep Table Specific Parts</b>																
15	Rail Hood	-8 (includes items 16 and 17)	3A7327A01	1	1	1	1	1	1	1	1	1	1	-		
		-8	3A9404A01											1	1	
		-12M (includes items 16 and 17)	3A7327A01	1	1	1	1	1	1	1	1	1	1	-		
		-12M	3A9403A01											1	1	
		-12 (includes items 16 and 17)	3A7329A01	1	1	1	1	1	1	1	1	1	1	-		
		-12	3A9394A01											1	1	
		-18M (includes items 16 and 17)	3A7327A01	1	1	1	1	1	1	1	1	1	1	-		
		-18M	3A9395A01											1	1	
		-16 (includes items 16 and 17)	3A7372A01	1	1	1	1	1	1	1	1	1	1	-		
		-16	3A9396A01											1	1	
		-24M, -24MD2, -24MD4 (includes items 16 and 17)	3A7372A01	1	1	1	1	1	1	1	1	1	1	-		
		-24M, -24MD2, -24MD4	3A9393A01											1	1	
16	Pivot Pin	-8, -12, -12M, -16, -18M	4A4768-01	2	2	2	2	2	2	2	2	2	2	2		
		-24M, -24MD2, -24MD4		4	4	4	4	4	4	4	4	4	4	4		
17	Pivot Bolt	-8, -12, -12M, -16, -18M	4A4769-01	2	2	2	2	2	2	2	2	2	2	2		
		-24M, -24MD2, -24MD4		4	4	4	4	4	4	4	4	4	4	4		

**Title: A. Main Assembly Models: CRMR60 and CRMF60 Undercounter, Worktop, and Prep Table**

Index No.	Description	Material or Model Number	Part Number	Required Number												
				B-5 to D-5	D-6 to D-7	D-8 to E-5 (B)	E-5 (C)	E-6 to E-8	E-9 to F-5	F-6 to F-6 (F)	F-6 (G)	F-7 to G-5 (A)	G-5 (B)	G-6	H-5	
				18	Rail Cover	-8 (includes items 19 through 20a)	3A7330A01	1	1	1	1	1	1	1	1	1
		-8 (includes items 16,17, 19 through 20a)	3A9405A01												1	1
		-12 (includes items 19 through 20a)	3A7331A01	1	1	1	1	1	1	1	1	1	1	-		
		-12 (includes items 16,17, 19 through 20a)	3A9398A01												1	1
		-12M (includes items 19 through 20a)	3A7332A01	1	1	1	1	1	1	1	1	1	1	-		
		-12M (includes items 16,17, 19 through 20a)	3A9402A01												1	1
		-16 (includes items 19 through 20a)	3A7346A01	1	1	1	1	1	1	1	1	1	1	-		
		-16 (includes items 16,17, 19 through 20a)	3A9400A01												1	1
		-18M (includes items 19 through 20a)	3A7333A01	1	1	1	1	1	1	1	1	1	1	-		
		-18M (includes items 16,17, 19 through 20a)	3A9399A01												1	1
	(includes 2 of items 16, 17 and all of 19, 20, and 20a)	-24M, -24MD2, -24MD4	3A7348A01	2	2	2	2	2	2	2	2	2	2	2	2	2
19	Tree Clip	-8, -12, -12M, -16, -18M	4A0579-01	2	2	2	2	2	2	2	2	2	2	2	2	2
		24M, -24MD2, -24MD4		3	3	3	3	3	3	3	3	3	3	3	3	3
20	Handle	-8, -12, -12M, -16, -18M	1A3416-01	1	1	1	1	1	1	1	1	1	1	1	1	1
		-24M, -24MD2, -24MD4		2	2	2	2	2	2	2	2	2	2	2	2	2
20a	Pan Head Screw	-8, -12, -12M, -16, -18M	7C12I1412	2	2	2	2	2	2	2	2	2	2	2	2	2
		-24M, -24MD2, -24MD4		4	4	4	4	4	4	4	4	4	4	4	4	4

Title: A. Main Assembly Models: CRMR60 and CRMF60 Undercounter, Worktop, and Prep Table															
Index No.	Description	Material or Model Number	Part Number	Required Number											
				B-5 to D-5	D-6 to D-7	D-8 to E-5 (B)	E-5 (C)	E-6 to E-8	E-9 to F-5	F-6 to F-6 (F)	F-6 (G)	F-7 to G-5 (A)	G-5 (B)	G-6	H-5
21	Right Cutting Board Bracket	-8, -12, -16,	4A5496-01	1	1	1	1	-							
			3A8653-02					1	1	1	-				
			3A8971-02								1	1	1	1	1
		-12M, -18M, -24M, -24MD2, -24MD4	1000000393	1	1	1	-								
			SP-5200				1	1	1	-					
		3A8971-02							1	1	1	1	1		
22	Left Cutting Board Bracket	-8, -12, -16,	4A5496-02	1	1	1	1	-							
			3A8653-01					1	1	1	-				
			3A8971-01								1	1	1	1	
		-12M, -18M, -24M, -24MD2, -24MD4	1000000392	1	1	1	-								
			SP-5200				1	1	1	-					
		3A8971-01							1	1	1	1			
23	Center Cutting Board Bracket	-8, -12, -16	4A5905-01								3	3	3	3	
		-12M, -18M, -24M, -24MD2, -24MD4	1000000394	3	3	3	3	3	3	3	-				
			4A5898-01								5	5	5	5	
24	Rail Divider (front-to-back)	-8 (HS-5188)	3A8904-01							1*	1	1	1	1	
		-12 (HS-5188)								2*	2	2	2	2	
		-16 (HS-5188)								3*	3	3	3	3	
		-12M (HS-5184)	3A8855-01							1*	1	1	1	1	
		-18M (HS-5184)								2*	2	2	2	2	
		-24M, -24MD2, -24MD4 (HS-5184)								2*	2	2	2	2	
25	Rail Divider (side-to-side)	-8 (HS-5189)	3A8905-01							2*	2	2	2	2	
	(outer side-to-side)	-12 (HS-5189)								3*	2	2	2	2	
		-16 (HS-5189)								4*	2	2	2	2	
	(side-to-side)	-12M (HS-5185)	3A8856-01							4*	4	4	4	4	
	(outer side-to-side)	-18M (HS-5185)								6*	4	4	4	4	
	(side-to-side)	-24M, -24MD2, -24MD4 (HS-5185)								8*	8	8	8	8	
26	Rail Divider C (center side to side)	-12 (HS-5190)	3A8906-01							1*	1	1	1	1	
		-16 (HS-5190)								2*	2	2	2	2	
		-18 (HS-5192)	3A8906-01							1*	1	1	1	1	
		-18M (HS-5186)	3A8857-01							2*	2	2	2	2	

\*E-8 and earlier must order 24, 25, and if applicable, 26

<b>Title: A. Main Assembly    Models: CRMR60 and CRMF60 Undercounter, Worktop, and Prep Table</b>															
Index No.	Description	Material or Model Number	Part Number	Required Number											
				B-5 to D-5	D-6 to D-7	D-8 to E-5 (B)	E-5 (C)	E-6 to E-8	E-9 to F-5	F-6 to F-6 (F)	F-6 (G)	F-7 to G-5 (A)	G-5 (B)	G-6	H-5
27	Spill Guard (includes items 28 through 32 )	-8 (HS-5223)	1A4221-01												1
		-12 (HS-5226)	1A4221-03												1
		-12M (HS-5207)	1A4115-01												1
		-16 (HS-5223)	1A4221-01												2
		-18M (HS-5213)	1A4154-01												1
		-24M, -24MD2, -24MD4 (HS-5207)	1A4115-01												2
28	Handle	-12M	4A4518-01											1	
		-16, 18M, -24M, -24MD2, -24MD4												2	
29	Handle Bracket	-12M	4A5297-01											1	
		-16, 18M, -24M, -24MD2, -24MD4												2	
30	Pan Head Screw	-12M	7C1210812											2	
		-16, 18M, -24M, -24MD2, -24MD4												4	
31	Split Lock Washer	-12M	7L2210832											2	
		-16, 18M, -24M, -24MD2, -24MD4												4	
32	Flat Washer	-12M	7W2210832											2	
		-16, 18M, -24M, -24MD2, -24MD4												4	



# A. Main Assembly

## CRMR72 Undercounter, Worktop, and Prep Table

B-5 to H-5

### Undercounter, Worktop, Prep Table

#### Common Parts

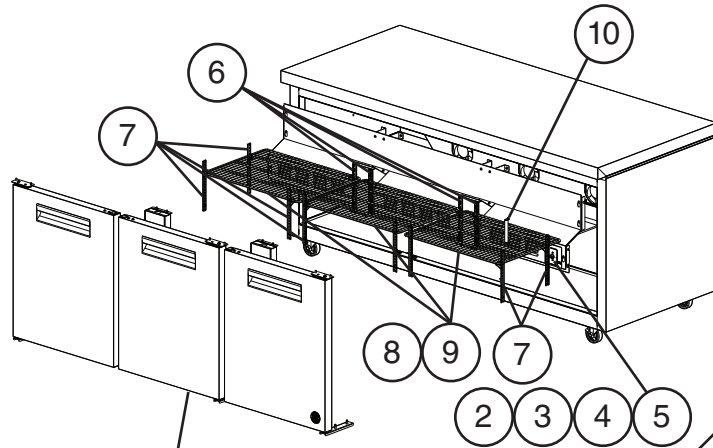

For Doors, see Sections "C" and "D"

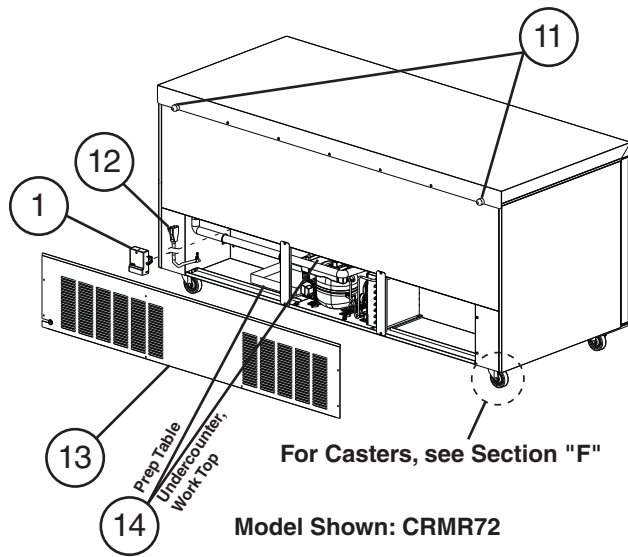

For Casters, see Section "F"

Model Shown: CRMR72

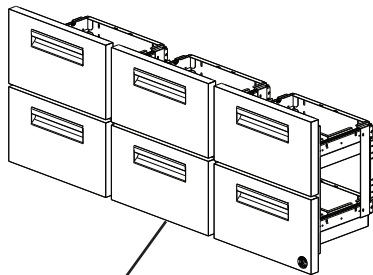

For Drawers, see Section "E"

#### Prep Table Specific Parts

For Pans, see Section "F"

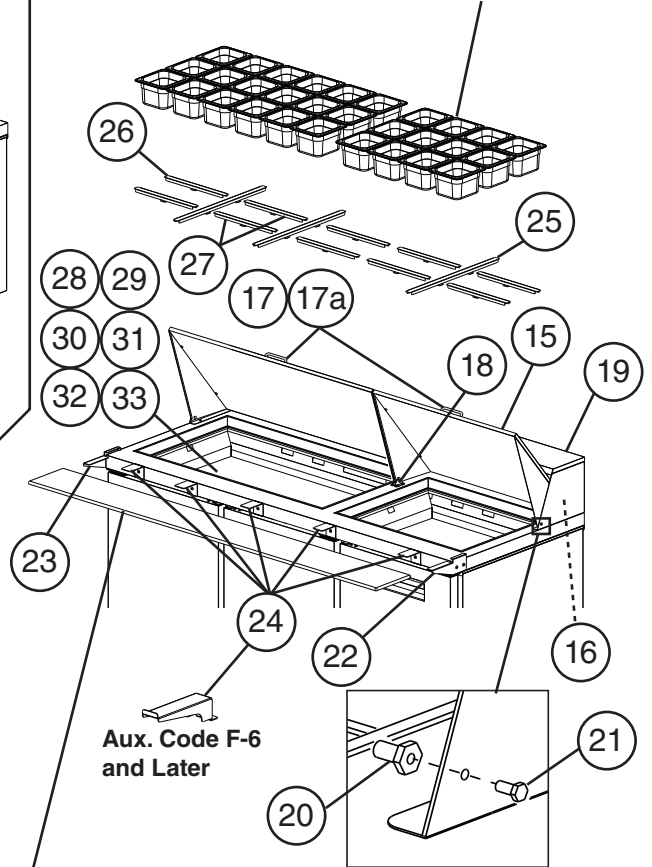

Aux. Code F-6  
and Later

Model Shown: CRMR72-30M

For Cutting Board,  
see Section "F"

Title: A. Main Assembly Models: CRMR72 Undercounter, Worktop, and Prep Table												
Index No.	Description	Material or Model Number	Part Number	Required Number								
				B-5 to D-7	D-8 to E-5	E-6 to E-8	E-9 to F-5 (H)	F-5 (J)	F-6	F-7 to G-5	G-6	H-5
<b>Common Parts</b>												
1	Control Module	UC/WT	4A5959G02					1	1	1	1	1
		Prep Table	4A5959G03							1	1	1
	Defrost Timer	Prep Table	3A7925-01		1	1	1	1	1	-		
2	Cabinet Temperature Control (Spindle)	UC/WT	3A6755-05	1	1	1	1	-				
			4A5952-01					1	1	1	1	1
		Prep Table	3A6755-05	1	1	1	1	1	1	-		
			4A5952-01							1	1	1
3	Adapter Plate	UC/WT	4A5949-01					1	1	1	1	1
		Prep Table								1	1	1
4	Dial Plate		4A5960-01	1	1	1	1	1	1	1	1	1
5	Dial Knob	UC/WT	3A6788-01	1	1	1	1	-				
			4A5950-01					1	1	1	1	1
		Prep Table	3A6788-01	1	1	1	1	1	1	-		
			4A5950-01							1	1	1
6	Rear Pilaster		4A5417-01	4	4	4	4	4	4	4	4	4
		-30MD2								2	2	2
7	Side and Front Pilaster		4A5524-01	8	8	-						
			4A5719-01			8	8	8	8	8	8	8
		-30MD2								6	6	6
		-30MD4								4	4	4
8	Shelf		3A2830-07	3	3	3	3	3	3	3	3	3
		-30MD2								2	2	2
		-30MD4								1	1	1
9	Shelf Clip		4A5418-01	12	12	12	12	12	12	12	12	12
		-30MD2								8	8	8
		-30MD4								4	4	4
10	Cabinet Thermometer		461083-01	1	1	1	1	1	1	1	1	
11	Bumpers		3A6696-01	2	2	2	2	2	2	2	2	
12	Power Cord		4A2860-01	1	1	1	1	1	1	1	1	
13	Rear Panel	All UC/WT	1A2525-01	1	1	1	1	1	1	1	1	1
		Prep Tables	1A2668-01	1	1	1	1	1	1	1	1	1

Title: A. Main Assembly Models: CRMR72 Undercounter, Worktop, and Prep Table													
Index No.	Description	Material or Model Number	Part Number	Required Number									
				B-5 to D-7	D-8 to E-5	E-6 to E-8	E-9 to F-5 (H)	F-5 (J)	F-6	F-7 to G-5	G-6	H-5	
<b>Prep Table Specific Parts</b>													
14	Condensate Pan	<b>UC/WT</b>	3A6758-01	1	1	1	1	1	1	1	1	1	
		<b>Prep Table</b>	2A7170-03	1	-								
			1A3373-01		1	1	1	1	1	1	1	1	
15	Rail Cover	<b>-12</b> (includes items 16 through 17a)	3A7331A01	1	1	1	1	1	1	1	1	-	
		<b>-12</b> (includes items 16 through 17a, 20, 21)	3A9398A01									1	1
		<b>-16</b> (includes items 16 through 17a)	3A7346A01	1	1	1	1	1	1	1	1	-	
		<b>-16</b> (includes items 16 through 17a, 20, 21)	3A9400A01									1	1
		<b>-18</b> (includes items 16 through 17a)	3A7378A01	1	1	1	1	1	1	1	1	-	
		<b>-18</b> (includes items 16 through 17a, 20, 21)	3A9401A01									1	1
		<b>-18M</b> (includes items 16 through 17a)	3A7333A01	1	1	1	1	1	1	1	1	-	
		<b>-18M</b> (includes items 16 through 17a, 20, 21)	3A9399A01									1	1
		<b>-24M</b> (includes items 16 through 17a)	3A7348A01	1	1	1	1	1	1	1	1	-	
		<b>-24M</b> (includes items 16 through 17a, 20, 21)	3A9392A01									1	1
		<b>-30M, -30MD2, -30MD4, 30MD6</b> (includes items 16 through 17a)	SP-5297	1	1	1	1	1	1	1	1	-	
		<b>-30M, -30MD2, -30MD4, 30MD6</b> (includes items 16 through 17a, 20, 21)	3A7376A01									1	1
16	Tree Clip	<b>-12, -16, 18, -18M</b>	4A0579-01	2	2	2	2	2	2	2	2	2	
		<b>-24M, -30M, -30MD2, -30MD4, 30MD6</b>		3	3	3	3	3	3	3	3	3	
17	Handle	<b>-12, -16, -18, -18M</b>	1A3416-01	1	1	1	1	1	1	1	1	1	
		<b>-24M, -30M, -30MD2, -30MD4, -30MD6</b>	1A3416-01	2	2	2	2	2	2	2	2	2	

Title: A. Main Assembly Models: CRMR72 Undercounter, Worktop, and Prep Table												
Index No.	Description	Material or Model Number	Part Number	Required Number								
				B-5 to D-7	D-8 to E-5	E-6 to E-8	E-9 to F-5 (H)	F-5 (J)	F-6	F-7 to G-5	G-6	H-5
17a	Pan Head Screws	-12, -16, -18, -18M	7C12I1412	2	2	2	2	2	2	2	2	2
		-24M, -30M, -30MD2, -30MD4, -30MD6		4	4	4	4	4	4	4	4	4
18	Rail Cover Bracket	-24M, -30M, -30MD2, -30MD4, -30MD6	4A5790-01	2	2	2	2	2	2	2	2	2
19	Rail Hood	-12 (includes items 20 and 21)	3A7329A01	1	1	1	1	1	1	1	-	
		-12	3A9394A01								1	1
		-18M (includes items 20 and 21)	3A7329A01	1	1	1	1	1	1	1	-	
		-18M	3A9395A01								1	1
		-16 (includes items 20 and 21)	3A7372A01	1	1	1	1	1	1	1	-	
		-16	3A9396A01								1	1
		-18 (includes items 20 and 21)	SP-5298	1	1	1	1	1	1	1	-	
		-18	3A9397A01								1	1
		-24M (includes items 20 and 21)	3A7372A01	1	1	1	1	1	1	1	-	
		-24M	3A9391A01								1	1
		-30M, -30MD2, -30MD4, -30MD6 (includes items 20 and 21)	SP-5298	1	1	1	1	1	1	1	-	
-30M, -30MD2, -30MD4, -30MD6	3A7373A01								1	1		
20	Pivot Pin	-12, -16, -18, -18M	4A4768-01	2	2	2	2	2	2	2	2	2
		-24M, -30M, -30MD2, -30MD4, -30MD6		4	4	4	4	4	4	4	4	4
21	Pivot Bolt	-12, -16, -18, -18M	4A4769-01	2	2	2	2	2	2	2	2	2
		-24M, -30M, -30MD2, -30MD4, -30MD6		4	4	4	4	4	4	4	4	4
22	Right Cutting Board Bracket	-12, -16, -18	4A5496-01	1	1	-						
			SP-5200			1	1	1	-			
			3A8971-02						1	1	1	1
		-18M, -24M, -30M, -30MD2, -30MD4, -30MD6	1000000393	1	1	-						
			SP-5200			1	1	1	-			
3A8971-02							1	1	1	1		

Title: A. Main Assembly Models: CRMR72 Undercounter, Worktop, and Prep Table													
Index No.	Description	Material or Model Number	Part Number	Required Number									
				B-5 to D-7	D-8 to E-5	E-6 to E-8	E-9 to F-5 (H)	F-5 (J)	F-6	F-7 to G-5	G-6	H-5	
23	Left Cutting Board Bracket	<b>-12, -16, -18</b>	4A5496-02	1	1	-							
			SP-5200			1	1	1	-				
			3A8971-01						1	1	1	1	
		<b>-18M, -24M, -30M, -30MD2, -30MD4, -30MD6</b>	1000000392	1	1	-							
			SP-5200			1	1	1	-				
			3A8971-01						1	1	1	1	
24	Center Cutting Board Bracket	<b>-12, -16, -18</b>	4A5905-01	3	3	3	3	3	3	3	3		
			<b>-18M, -24M, -30M, -30MD2, -30MD4, -30MD6</b>	1000000394	3	3	3	3	3	-			
			4A5898-01						5	5	5	5	
25	Rail Divider (front-to-back)	<b>-12, -18</b> (HS-5188)	3A8904-01	E-8 and earlier must order items 25, 26, and if applicable, 27	2	2	2	2	2	2	2		
					<b>-16</b> (HS-5188)	3	3	3	3	3	3		
		<b>-18M</b> (HS-5184)	3A8855-01		2	2	2	2	2	2			
					<b>-24M, -30M, -30MD2, -30MD4, -30MD6</b> (HS-5184)	3	3	3	3	3	3		
		26	Rail Divider (side-to-side) (outer side to side)		<b>-12</b> (HS-5189)	3A8905-01	2	2	2	2	2	2	2
							<b>-16</b> (HS-5189)	2	2	2	2	2	2
<b>-18</b> (HS-5191)	3A8905-02			2	2	2	2	2	2				
				<b>-18M, -30MD2, -30MD4</b> (HS-5185)	4	4	4	4	4	4			
<b>-24M</b> (HS-5185)	8			8	8	8	8	8					
<b>-30M, -30MD6</b> (HS-5185)	8			8	8	8	8	8					
27	Rail Divider C (center side-to-side)	<b>-12</b> (HS-5190)	3A8906-01	1	1	1	1	1	1	1			
				<b>-16</b> (HS-5190)	2	2	2	2	2	2			
		<b>-18</b> (HS-5192)	3A8906-02	1	1	1	1	1	1				
				<b>-18M, -30M, 30MD2, -30MD4, -30MD6</b> (HS-5186)	2	2	2	2	2	2			

<b>Title: A. Main Assembly    Models: CRMR72 Undercounter, Worktop, and Prep Table</b>													
Index No.	Description	Material or Model Number	Part Number	Required Number									
				B-5 to D-7	D-8 to E-5	E-6 to E-8	E-9 to F-5 (H)	F-5 (J)	F-6	F-7 to G-5	G-6	H-5	
28	Spill Guard (includes items 28 through 33)	<b>-12, -18</b> (HS-5226)	1A4221-03										1
		<b>-16</b> (HS-5223)	1A4221-01										1
		<b>-18</b> (HS-5225)	1A4221-02										1
		<b>-18M, -30M, -30MD2, -30MD4, -30MD6</b> (HS-5213)	1A4154-01										1
		<b>-24M</b> (HS-5207)	1A4115-01										2
		<b>-30M, -30MD2, -30MD4, -30MD6</b> (HS-5207)											1
29	Handle	<b>-18M, -24M</b>	4A4518-01									2	
		<b>-30M, -30MD2, -30MD4, -30MD6</b>										3	
30	Handle Bracket	<b>-18M, -24M</b>	4A5297-01									2	
		<b>-30M, -30MD2, -30MD4, -30MD6</b>										3	
31	Pan Head Screw	<b>-18M, -24M</b>	7C12I0812									4	
		<b>-30M, -30MD2, -30MD4, -30MD6</b>										6	
32	Split Lock Washer	<b>-18M, -24M</b>	7L22I0832									4	
		<b>-30M, -30MD2, -30MD4, -30MD6</b>										6	
33	Flat Washer	<b>-18M, -24M</b>	7W22I0832									4	
		<b>-30M, -30MD2, -30MD4, -30MD6</b>										6	

**B. Refrigeration Circuit**  
**CRMR27 Undercounter, Worktop, and Prep Table**  
 A-5 to H-5

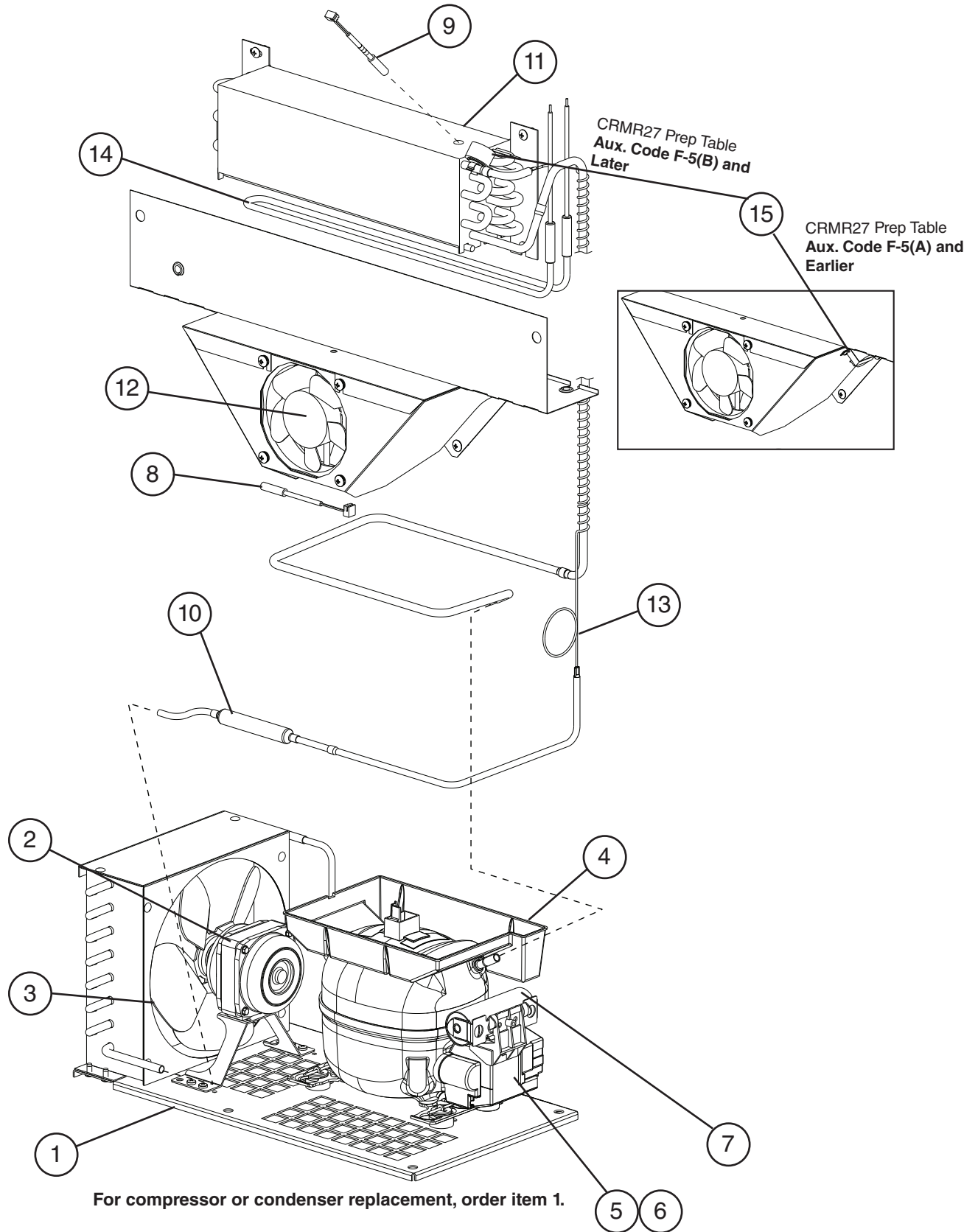

<b>Title: B. Refrigeration Circuit    Models: CRMR27 Undercounter, Worktop, Prep Table</b>													
Index No.	Description	Material or Model Number	Part Number	Required Number									
				A-5 to D-6	D-8 to F-5 (A)	F-5 (B)	F-6	F-7 to H-5					
1	Condensing Unit (includes compressor, condenser, and items 2 through 7; compressor and condenser are not sold individually)	<b>UC/WT/ Prep Table</b>	3A8106-01	1	1	1	1	1					
2	Condenser Fan Motor		3A6798-01	1	1	1	1	1					
3	Condenser Fan Blade		3A6799-01	1	1	1	1	1					
4	Condensate Pan		3A6758-01	1	1	1	1	1					
5	Compressor External Protector		3A6746-01	1	1	1	1	1					
6	Start Relay	<b>UC/WT/ Prep Table</b>	1000000412	1	1	1	1	1					
7	Start Capacitor (C-6 and earlier models did not have start capacitor)	<b>UC/WT/Prep Table</b> 233-280MFD, 165VAC	1000000279	1	1	1	1	1					
8	Cabinet Thermistor	<b>UC/WT</b>	4A4864-01				1	1					
		<b>Prep Tables</b>					1						
9	Defrost Thermistor	<b>Prep Table</b>	4A4865-01					1					
10	Drier		4A5576-01	1	1	1	1	1					
11	Evaporator		2A8513-01	1	1	1	1	1					
12	Evaporator Fan Motor		4A5343-01	1	1	1	1	1					
13	Capillary Tube Replacement Kit	L=2438 mm	SP-5119	1	1	1	1	1					
14	Defrost Heater	<b>Prep Table</b>	3A6443-05		1	1	1	1					
15	Defrost Safety Thermostat	<b>Prep Table</b>	4A0954-01		1	-							
			4A5853-01			1	1	1					



## B. Refrigeration Circuit

### CRMF27 Undercounter and Worktop

A-5 to H-5

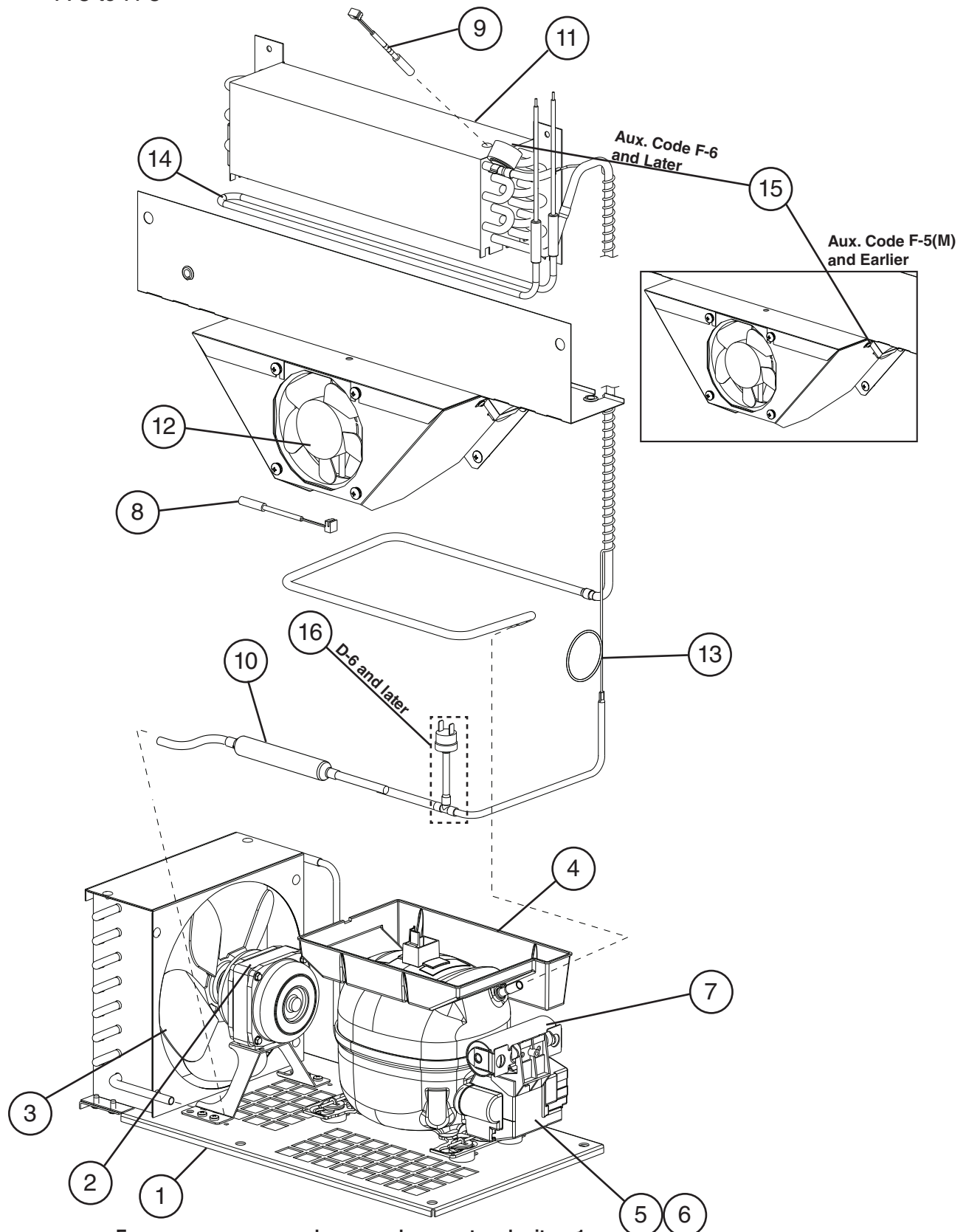

Title: B. Refrigeration Circuit Models: CRMF27 Undercounter and Worktop												
Index No.	Description	Material or Model Number	Part Number	Required Number								
				A-5 to D-5	D-6 to F-5 (E)	F-5 (F)	F-6	F-7 to G-5	G-6 H-5			
1	Condensing Unit (includes compressor, condenser, and items 2 through 7; compressor and condenser are not sold individually)		3A8107-01	1	1	1	1	1	1	1		
2	Condenser Fan Motor		3A6798-01	1	1	1	1	1	1	1		
3	Condenser Fan Blade		3A6799-01	1	1	1	1	1	1	1		
4	Condensate Pan		3A6758-01	1	1	1	1	1	1	1		
5	Compressor External Protector		3A6774-01	1	1	1	1	1	1	1		
6	Start Relay		3A7232-01	1	1	1	1	1	1	1		
7	Start Capacitor	270-327MFD, 165VAC	4A5525-01	1	1	1	1	1	1	1		
8	Cabinet Thermistor	CRMF27-W(-LP)	4A4864-01			1	1	1	1			
		All Freezers Except CRMF27-W(-LP)						1	1			
9	Defrost Thermistor	CRMF27-W(-LP)	4A4865-01			1	1	1	1			
		All Freezers Except CRMF27-W(-LP)						1	1			
10	Drier		4A5576-01	1	1	1	1	1	1	1		
11	Evaporator		2A8513-01	1	1	1	1	1	1	1		
12	Evaporator Fan Motor		4A5343-01	1	1	1	1	1	1	1		
13	Capillary Tube Replacement Kit	SP-5120	3A8129A01	1	1	1	1	1	1	1		
14	Defrost Heater		3A6443-05	1	1	1	1	1	1	1		
15	Defrost Safety Thermostat		4A0954-02	1	1	1	-					
			4A5853-01				1	1	1			
16	High-Pressure Switch		4A2516-01		1	1	1	1	1	1		

## B. Refrigeration Circuit CRMR36 Undercounter, Worktop, and Prep Table F-5 to H-5

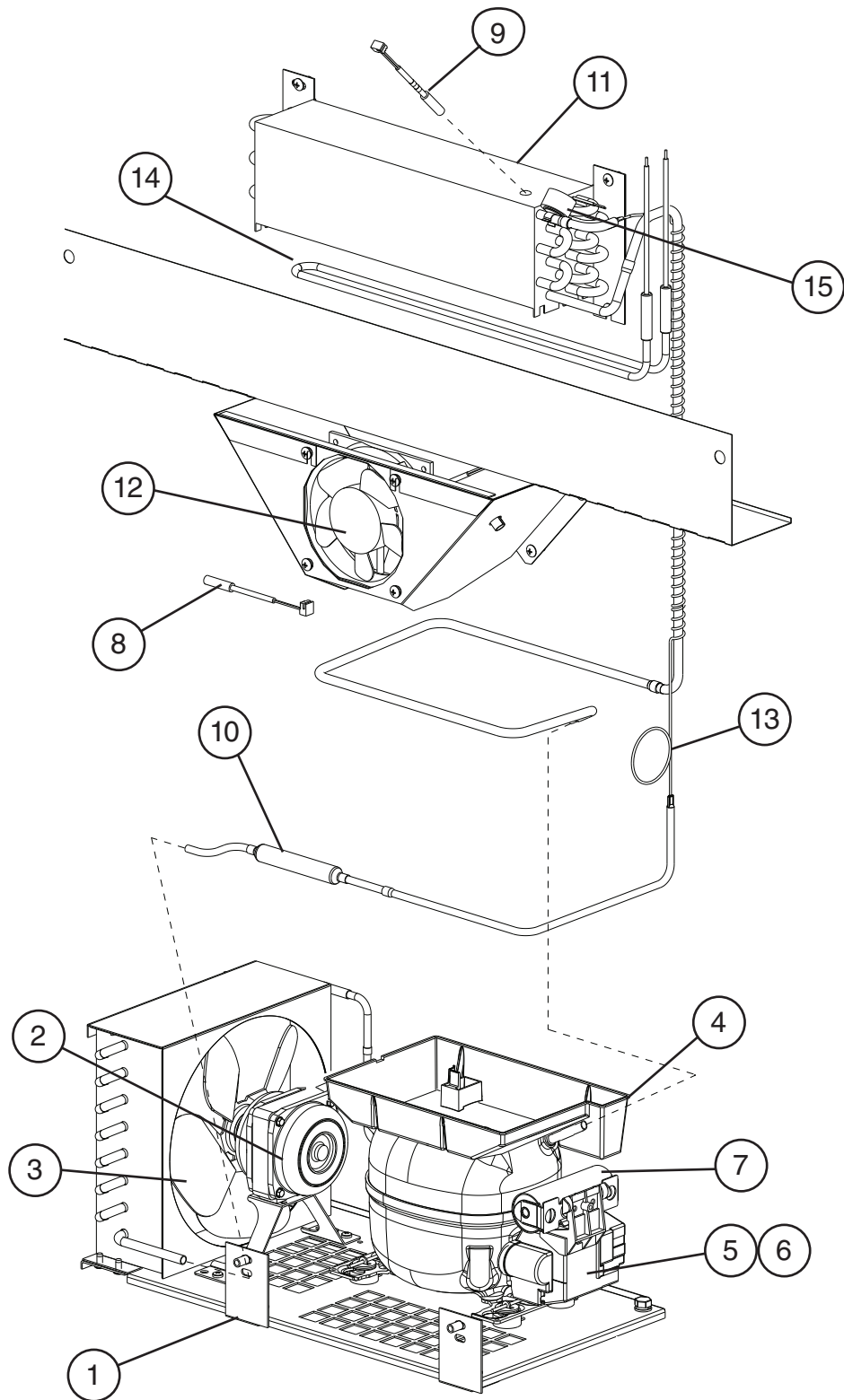

For compressor or condenser replacement, order item 1.

Title: B. Refrigeration Circuit Models: CRMR36 Undercounter, Worktop, Prep Table												
Index No.	Description	Material or Model Number	Part Number	Required Number								
				F-5 to G-5	G-6 H-5							
1	Condensing Unit (includes compressor, condenser, and items 2 through 7; compressor and condenser are not sold individually)		3A8106-01	1	1							
2	Condenser Fan Motor		3A6798-01	1	1							
3	Condenser Fan Blade		3A6799-01	1	1							
4	Condensate Pan		3A6758-01	1	1							
5	Compressor External Protector		3A6746-01	1	1							
6	Start Relay		1000000412	1	1							
7	Start Capacitor	233-280MFD, 165VAC	1000000279	1	1							
8	Cabinet Thermistor		4A4864-01	1	1							
9	Defrost Thermistor	<b>Prep Table</b>	4A4865-01	1	1							
10	Drier		4A5576-01	1	1							
11	Evaporator		2A8513-01	1	1							
12	Evaporator Fan Motor		4A5343-01	1	1							
13	Capillary Tube (includes: capillary tube, drier, cover, insulation)	SP-5119	3A8129A01	1	1							
14	Defrost Heater	<b>Prep Table</b>	3A6443-05	1	1							
15	Defrost Safety Thermostat (thermodisc)	<b>Prep Table</b>	4A5853-01	1	1							

## B. Refrigeration Circuit

### CRMR48 Undercounter, Worktop, and Prep Table

A-5 to H-5

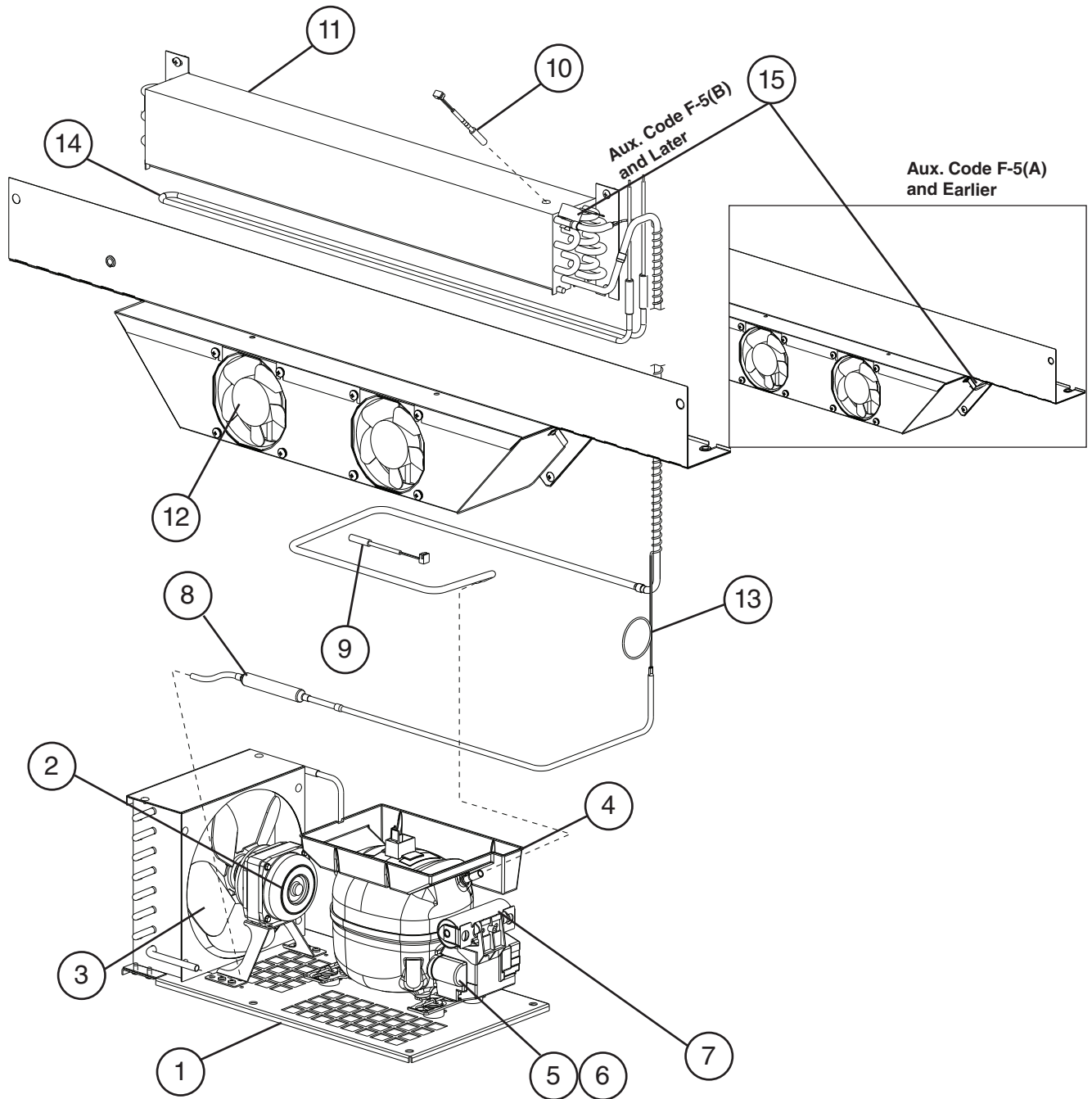

For compressor or condenser replacement, order item 1.

Title: B. Refrigeration Circuit Models: CRMR48 Undercounter, Worktop, and Prep Table													
Index No.	Description	Material or Model Number	Part Number	Required Number									
				A-5 to C-6	C-7 to F-5 (A)	F-5 (B) to F-6 (G)	F-6 (H)	F-7 to G-5	G-6 H-5				
1	Condensing Unit (includes compressor, condenser, and items 2 through 8; compressor and condenser are not sold individually)	<b>UC/WT/ Prep Table</b>	3A8106-01	1	1	1	1	1	1				
2	Condenser Fan Motor		3A6798-01	1	1	1	1	1	1				
3	Condenser Fan Blade		3A6799-01	1	1	1	1	1	1				
4	Condensate Pan		3A6758-01	1	1	1	1	1	1				
5	Compressor External Protector		3A6746-01	1	1	1	1	1	1				
6	Start Relay	<b>UC/WT/ Prep Table</b>	1000000412	1	1	1	1	1	1				
7	Start Capacitor (C-6 and earlier models did not have start capacitor)	<b>UC/WT/ Prep Table</b> 233-280MFD, 165VAC	1000000279	1	1	1	1	1	1				
8	Drier		4A5576-01	1	1	1	1	1	1				
9	Cabinet Thermistor	<b>CRMR48(-W)</b>	4A4864-01				1	1	1				
		<b>All UC/WT Refrigerators Except CRMR48(-W)</b>						1	1				
		<b>Prep Table</b>						1	1				
10	Defrost Thermistor	<b>Prep Table</b>	4A4865-01					1	1				
11	Evaporator		2A8513-02	1	1	1	1	1	1				
12	Evaporator Fan Motor		4A5343-01	2	2	2	2	2	2				
13	Capillary Tube Replacement Kit		SP-5119	1	1	1	1	1	1				
14	Defrost Heater	<b>Prep Table</b>	3A6443-04		1	1	1	1	1				
15	Defrost Safety Thermostat	<b>Prep Table</b>	4A0954-02		1	-							
			4A5853-01			1	1	1	1				

**B. Refrigeration Circuit**  
**CRMF48 Undercounter and Worktop**  
 A-5 to H-5

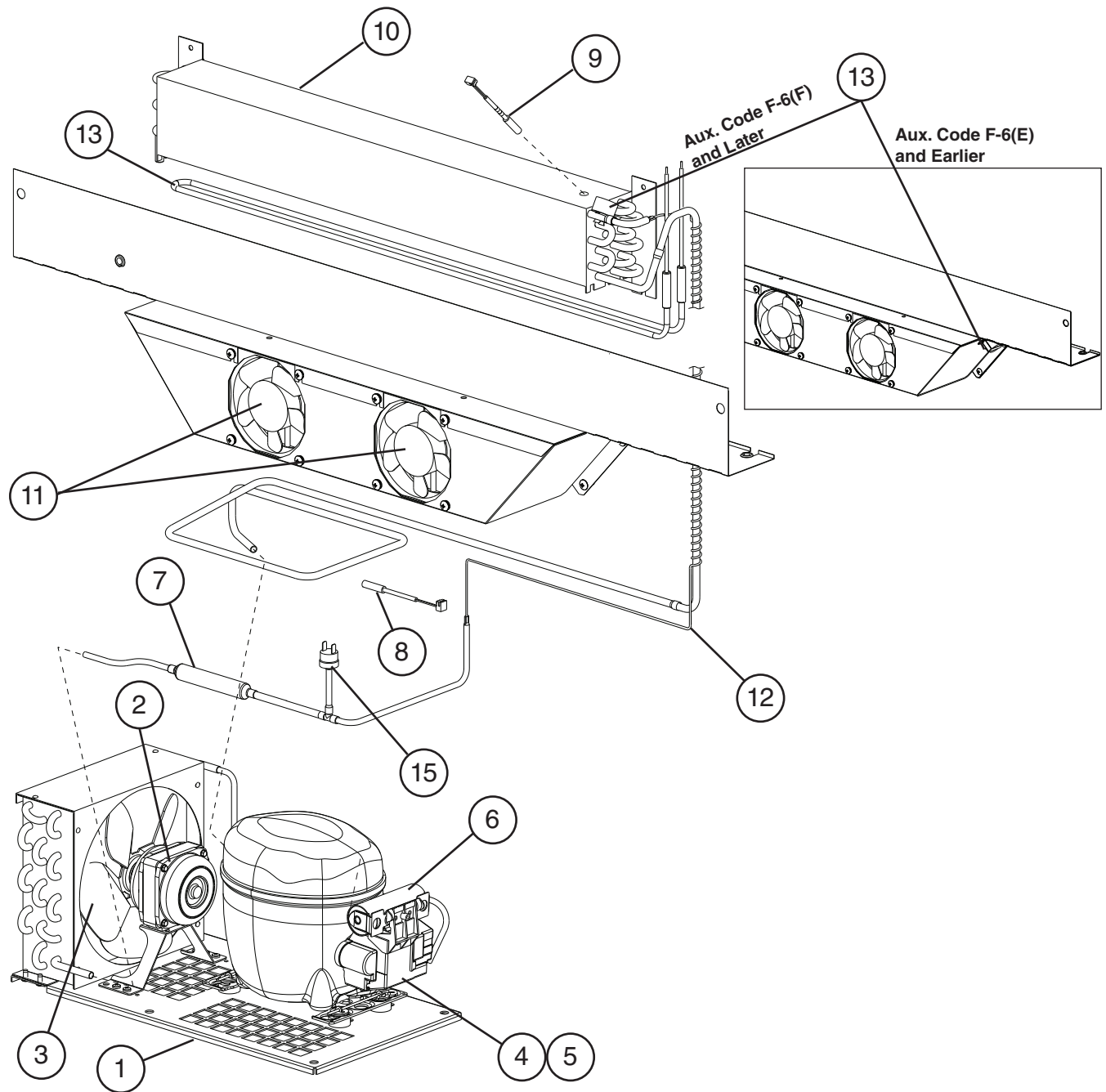

For compressor or condenser replacement, order item 1.

Title: B. Refrigeration Circuit    Models: CRMF48 Undercounter and Worktop												
Index No.	Description	Material or Model Number	Part Number	Required Number								
				A-5 to F-6 (E)	F-6 (F)	F-7	G-5	G-6 H-5				
1	Condensing Unit (includes compressor, condenser, and items 2 through 6; compressor and condenser are not sold individually)		3A8108-01	1	1	1	1	1				
2	Condenser Fan Motor		3A6798-01	1	1	1	1	1				
3	Condenser Fan Blade		3A6799-01	1	1	1	1	1				
4	Compressor External Protector		3A6936-01	1	1	1	1	1				
5	Start Relay		3A6937-01	1	1	1	1	1				
6	Start Capacitor	378-454MFD, 115VAC	3A6938-01	1	1	1	1	1				
7	Drier		4A5576-01	1	1	1	1	1				
8	Cabinet Thermistor	CRMF48(-W)	4A4864-01		1	1	1	1				
		All Freezers Except CRMF48(-W)				1	1	1				
9	Defrost Thermistor	CRMF48(-W)	4A4865-01		1	1	1	1				
		All Freezers Except CRMF48(-W)				1	1	1				
10	Evaporator		2A8513-02	1	1	1	1	1				
11	Evaporator Fan Motor		4A5471-01	2	2	2	-					
			4A5343-01				2	2				
12	Capillary Tube Replacement Kit		SP-5121	1	1	1	1	1				
13	Defrost Heater		3A6443-04	1	1	1	1	1				
14	Defrost Safety Thermostat		4A0954-02	1	-							
			4A5853-01		1	1	1	1				
15	High-Pressure Switch		4A2516-02	1	1	1	1	1				



**B. Refrigeration Circuit**  
**CRMR60 Undercounter, Worktop, and Prep Table**  
 B-5 to H-5

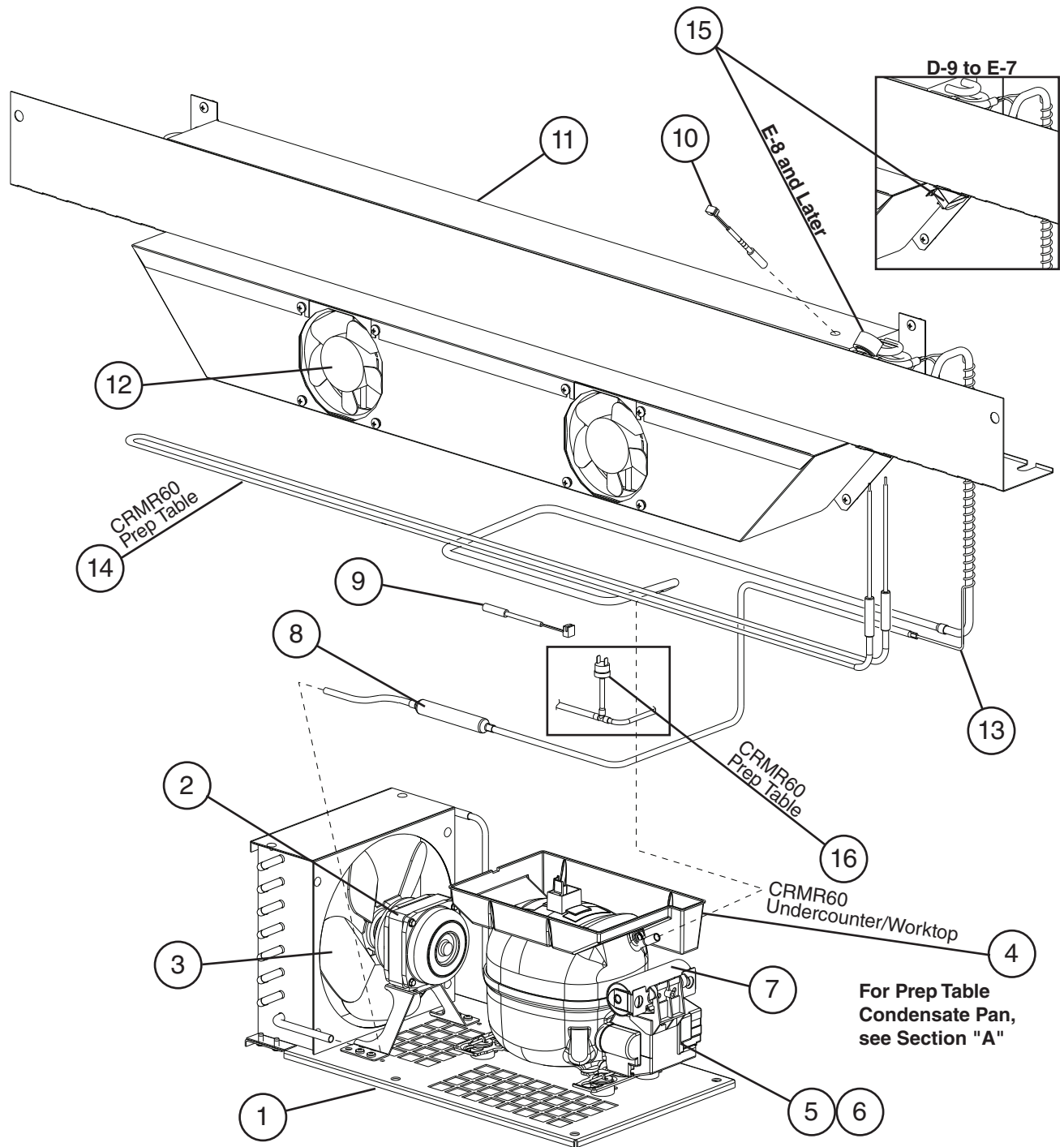

For compressor or condenser replacement, order item 1.

<b>Title: B. Refrigeration Circuit    Models: CRMR60 Undercounter, Worktop, and Prep Table</b>												
Index No.	Description	Material or Model Number	Part Number	Required Number								
				B-5 to D-6	D-8 to E-7	E-8 to F-5	F-6	F-7 to G-5	G-6 H-5			
1	Condensing Unit (includes compressor, condenser, and items 2 through 7; compressor and condenser are not sold individually)	<b>UC/WT</b>	3A8107-01	1	1	1	1	1	1			
		<b>Prep Table</b>	3A8108-01	1	1	1	1	1	1			
2	Condenser Fan Motor		3A6798-01	1	1	1	1	1	1			
3	Condenser Fan Blade		3A6799-01	1	1	1	1	1	1			
4	Condensate Pan	<b>UC/WT</b>	3A6758-01	1	1	1	1	1	1			
5	Compressor External Protector	<b>UC/WT</b>	3A6774-01	1	1	1	1	1	1			
		<b>Prep Table</b>	3A6936-01	1	1	1	1	1	1			
6	Start Relay	<b>UC/WT</b>	3A7232-01	1	1	1	1	1	1			
		<b>Prep Table</b>	3A6937-01	1	1	1	1	1	1			
7	Start Capacitor	<b>UC/WT</b> 270-327MFD, 165VAC	4A5525-01	1	1	1	1	1	1			
		<b>Prep Table</b> 378-454MFD, 115VAC	3A6938-01	1	1	1	1	1	1			
8	Drier		4A5576-01	1	1	1	1	1	1			
9	Cabinet Thermistor	<b>UC/WT</b>	4A4864-02				1	1	1			
		<b>Prep Table</b>					1	1				
10	Defrost Thermistor	<b>Prep Table</b>	4A4865-02					1	1			
11	Evaporator		2A8513-03	1	1	1	1	1	1			
12	Evaporator Fan Motor		4A5343-01	2	2	2	2	2	2			
13	Capillary Tube Replacement Kit	<b>UC/WT</b>	SP-5120	1	1	1	1	1	1			
		<b>Prep Table</b>	SP-5227	1	1	1	1	1	1			
14	Defrost Heater	<b>Prep Table</b>	3A6443-06		1	1	1	1	1			
15	Defrost Thermostat	<b>Prep Table</b>	4A0954-02		1	-						
			4A5853-01			1	1	1	1			
16	High-Pressure Switch	<b>Prep Table</b>	4A2516-01	1	1	1	1	1	1			

**B. Refrigeration Circuit**  
**CRMF60 Undercounter and Worktop**  
 C-5 to H-5

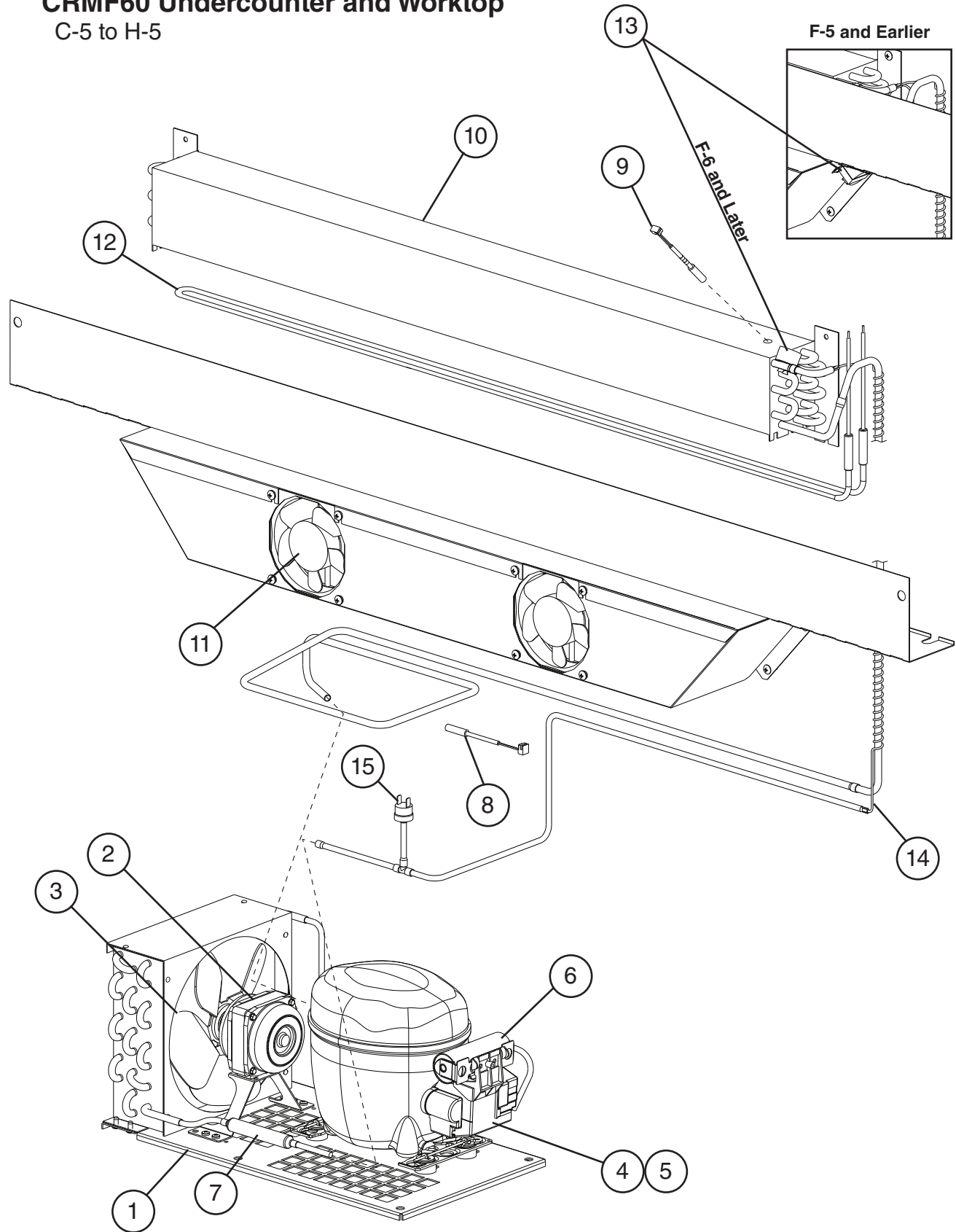

For compressor or condenser replacement, order item 1.

Title: B. Refrigeration Circuit Models: CRMF60 Undercounter and Worktop												
Index No.	Description	Material or Model Number	Part Number	Required Number								
				C-5 to D-6	D-8 to F-5	F-6	G-5	G-6 H-5				
1	Condensing Unit (includes compressor, condenser, and items 2 through 7; compressor and condenser are not sold individually)		3A8108-01	1	1	1	1	1				
2	Condenser Fan Motor		3A6798-01	1	1	1	1	1				
3	Condenser Fan Blade		3A6799-01	1	1	1	1	1				
4	Compressor External Protector		3A6936-01	1	1	1	1	1				
5	Start Relay		3A6937-01	1	1	1	1	1				
6	Start Capacitor	378-454MFD, 115VAC	3A6938-01	1	1	1	1	1				
7	Drier		4A5576-01	1	1	1	1	1				
8	Cabinet Thermistor		4A4864-02			1	1	1				
9	Defrost Thermistor		4A4865-02			1	1	1				
10	Evaporator		2A8513-03	1	1	1	1	1				
11	Evaporator Fan Motor		4A5471-01	2	2	2	-	-				
			4A5343-01				2	2				
12	Defrost Heater		3A6443-06	1	1	1	1	1				
13	Defrost Thermostat		4A0954-02	1	1	-						
			4A5853-01			1	1	1				
14	Capillary Tube Replacement Kit		SP-5121	1	1	1	1	1				
15	High-Pressure Switch		4A2516-01	1	1	1	1	1				

## B. Refrigeration Circuit

### CRMR72 Undercounter, Worktop, Prep Table

B-5 to H-5

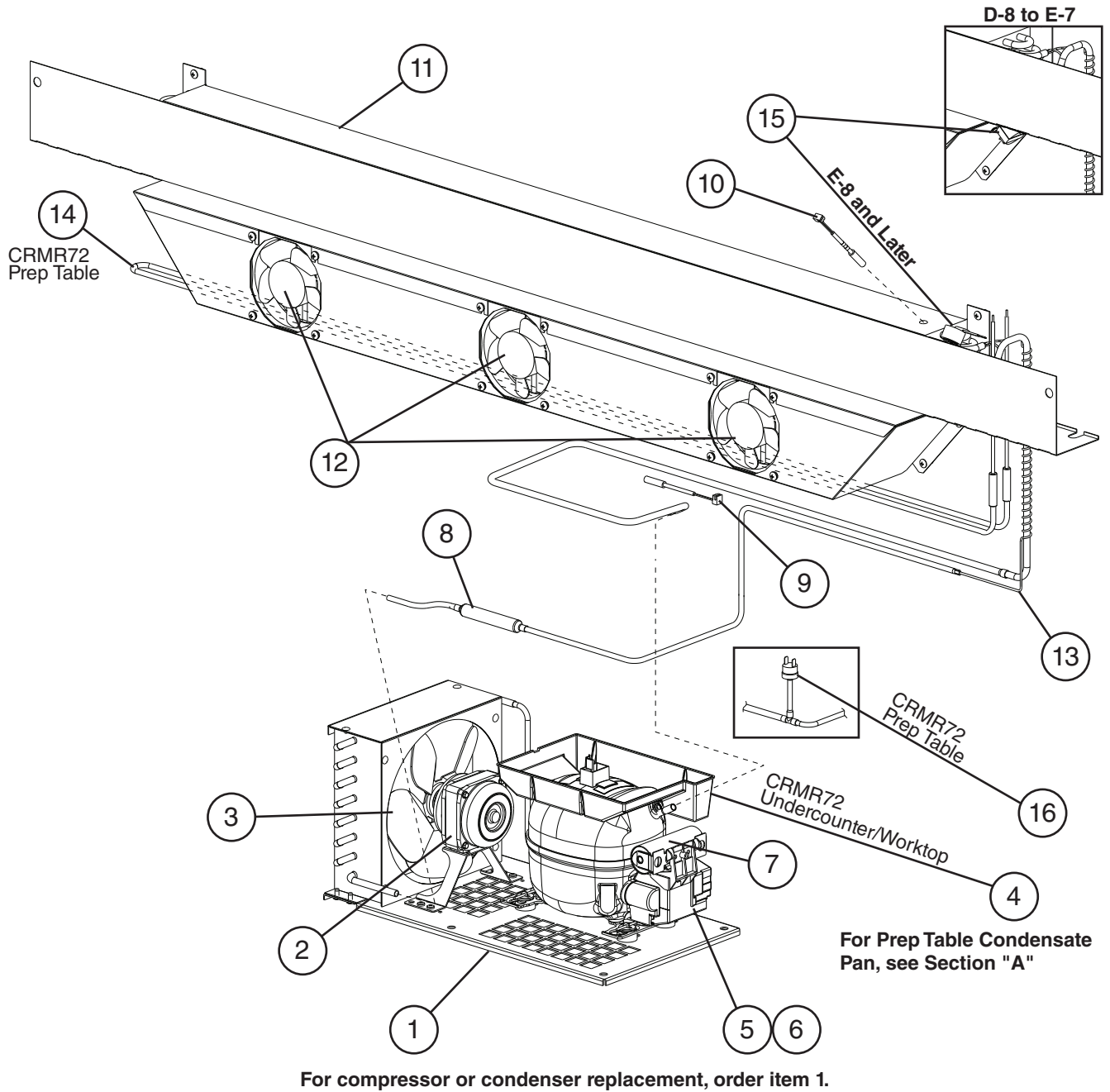

Title: B. Refrigeration Circuit Models: CRMR72 Undercounter, Worktop, and Prep Table												
Index No.	Description	Material or Model Number	Part Number	Required Number								
				B-5 to D-7	D-8 to E-7	E-8 to F-5 (H)	F-5 (J) to F-6	F-7 to G-5	G-6 H-5			
1	Condensing Unit (includes compressor, condenser, and items 2 through 7; compressor and condenser are not sold individually)	UC/WT	3A8107-01	1	1	1	1	1	1			
		Prep Table	3A8108-01	1	1	1	1	1	1			
2	Condenser Fan Motor		3A6798-01	1	1	1	1	1	1			
3	Condenser Fan Blade		3A6799-01	1	1	1	1	1	1			
4	Condensate Pan	UC/WT	3A6758-01	1	1	1	1	1	1			
5	Compressor External Protector	UC/WT	3A6774-01	1	1	1	1	1	1			
		Prep Table	3A6936-01	1	1	1	1	1	1			
6	Start Relay	UC/WT	3A7232-01	1	1	1	1	1	1			
		Prep Table	3A6937-01	1	1	1	1	1	1			
7	Start Capacitor	UC/WT 270-327MFD, 165VAC	4A5525-01	1	1	1	1	1	1			
		Prep Table 378-454MFD, 115VAC	3A6938-01	1	1	1	1	1	1			
8	Drier		4A5576-01	1	1	1	1	1	1			
9	Cabinet Thermistor	UC/WT	4A4864-02				1	1	1			
		Prep Table						1	1			
10	Defrost Thermister	Prep Table	4A4865-02					1	1			
11	Evaporator		2A8513-04	1	1	1	1	1	1			
12	Evaporator Fan Motor		4A5343-01	3	3	3	3	3	3			
13	Capillary Tube Replacement Kit	UC/WT	SP-5120	1	1	1	1	1	1			
		Prep Table	SP-5227	1	1	1	1	1	1			
14	Defrost Heater	Prep Table	3A6443-07		1	1	1	1	1			
15	Defrost Safety Thermostat	Prep Table	4A0954-02		1	-						
			4A5853-01			1	1	1	1			
16	High-Pressure Switch	Prep Table	4A2516-01	1	1	1	1	1	1			

### C. Door-Right Hinged Undercounter, Worktop, Prep Table A-5 to H-5

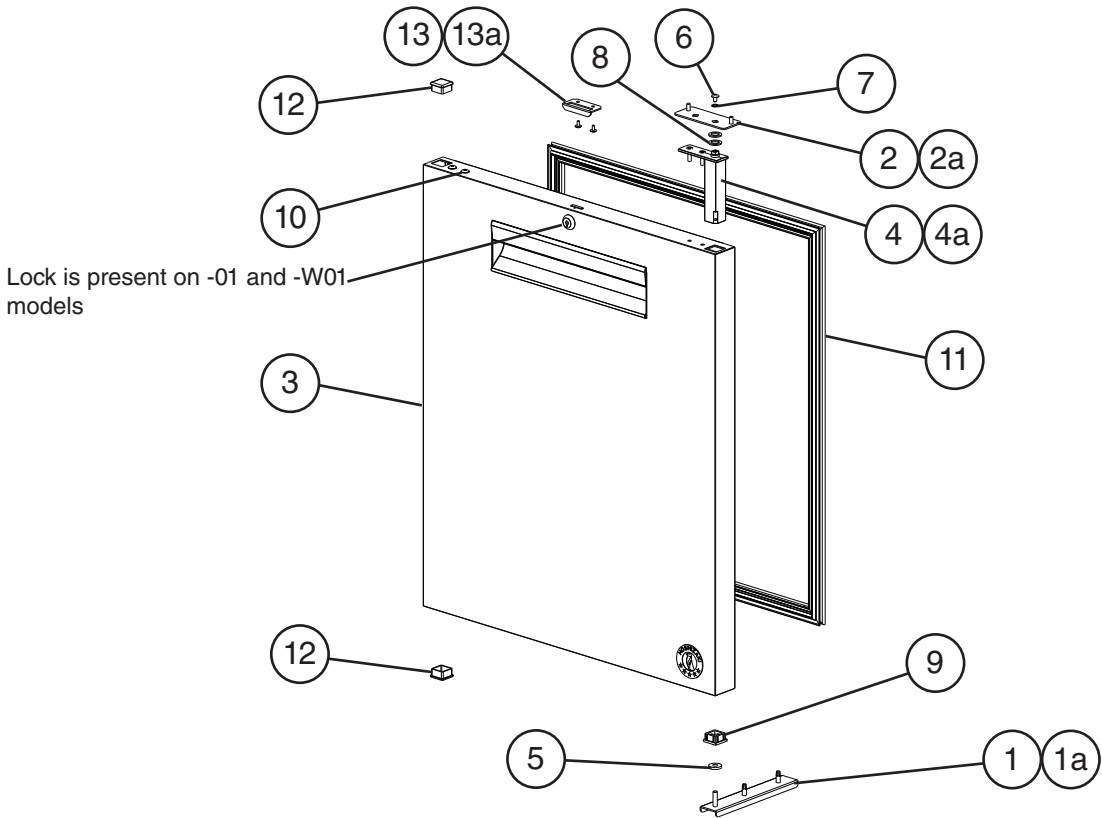

Title: C. Door-Right Hinged    Models: Undercounter, Worktop, Prep Table				Required Number							
Index No.	Description	Material or Model Number	Part Number	A-5 to D-6 (D)	D-6 (E) to G-5 H-5						
1	Lower Hinge Bracket		3A6681G01	1	1	1					
1a	Hex Head Tapping Bolt	1/4-20x3/4	4A5213-01	2	2	2					
2	Upper Hinge Bracket		3A6810-01	1	1	1					
2a	Truss Head Screw	5x12, SS	7C32-0512	2	2	2					

<b>Title: C. Door-Right Hinged    Models: Undercounter, Worktop, Prep Table</b>											
Index No.	Description	Material or Model Number	Part Number	Required Number							
				A-5 to D-6 (D)	D-6 (E) to G-5	G-6 H-5					
3	Door Assembly without Locks (includes items 4 through 12)	<b>CRM_27 UC/WT/Prep Table (All except -01 and -W01)</b>	2A7322G01	1	1	1					
		<b>CRMR36 UC/WT/Prep Table (All except -01 and -W01)</b>	2A7328G01	1	1	1					
		<b>CRM_48 and CRMR72 UC/WT/Prep Table (All except -01 and -W01)</b>	2A7324G01	1	1	1					
		<b>CRMR60 UC/WT/Prep Table (All except -01 and -W01)</b>	2A7328G01	1	1	1					
	Door Assembly with Locks (includes items 4 through 12)	<b>CRM_R27-01(-W01) UC/WT/Prep Table</b>	2A7323G01	1	1	1					
		<b>CRM_48-01(-W01) and CRMR72-01(-W01) UC/WT/Prep Table</b>	2A7327G01	1	1	1					
4	Hinge Spring Cartridge (includes items 5 through 9)		3A9206-01	1	1	1					
4a	Countersunk Screw	5x20, SS	7C42-0520	2	2	2					
5	Thrust Washer		4A5234-01	1	1	1					
6	Screw		4A5230-01	1	1	1					
7	Lockwasher		4A5231-01	1	1	1					
8	Thrust Washer		4A5233-01	2	2	2					
9	Bearing		4A5232-01	1	1	1					
10	Truss Head Screw (filler screws)	5x10, SS	7C32-0510	2	2	2					



Title: C. Door-Right Hinged Models: Undercounter, Worktop, Prep Table											
Index No.	Description	Material or Model Number	Part Number	Required Number							
				A-5 to D-6 (D)	D-6 (E) to G-5 H-5						
11	Gasket	<b>CRM_27 UC/WT/Prep Table</b>	2A5192-05	1	-						
			2A6996-05		1	1					
		<b>CRMR36 UC/WT/Prep Table</b>	2A6996-09	1	1	1					
			<b>CRM_48 and CRMR72 UC/WT/Prep Table</b>	2A5192-06	1	-					
		2A6996-06			1	1					
		<b>CRM_60 UC/WT/Prep Table</b>	2A5192-09	1	-						
2A6996-09			1	1							
12	End Cap		4A5432-01	2	2	2					
13	Strike Plate for Doors with Locks	<b>-01(-W01) UC/WT/Prep Table</b>	4A5493-01	1	1	1					
13a	T2 Screw	<b>-01(-W01) UC/WT/Prep Table</b> 4x8, SS	7P32-0408	2	2	2					

# D. Door-Left Hinged Undercounter, Worktop, Prep Table A-5 to H-5

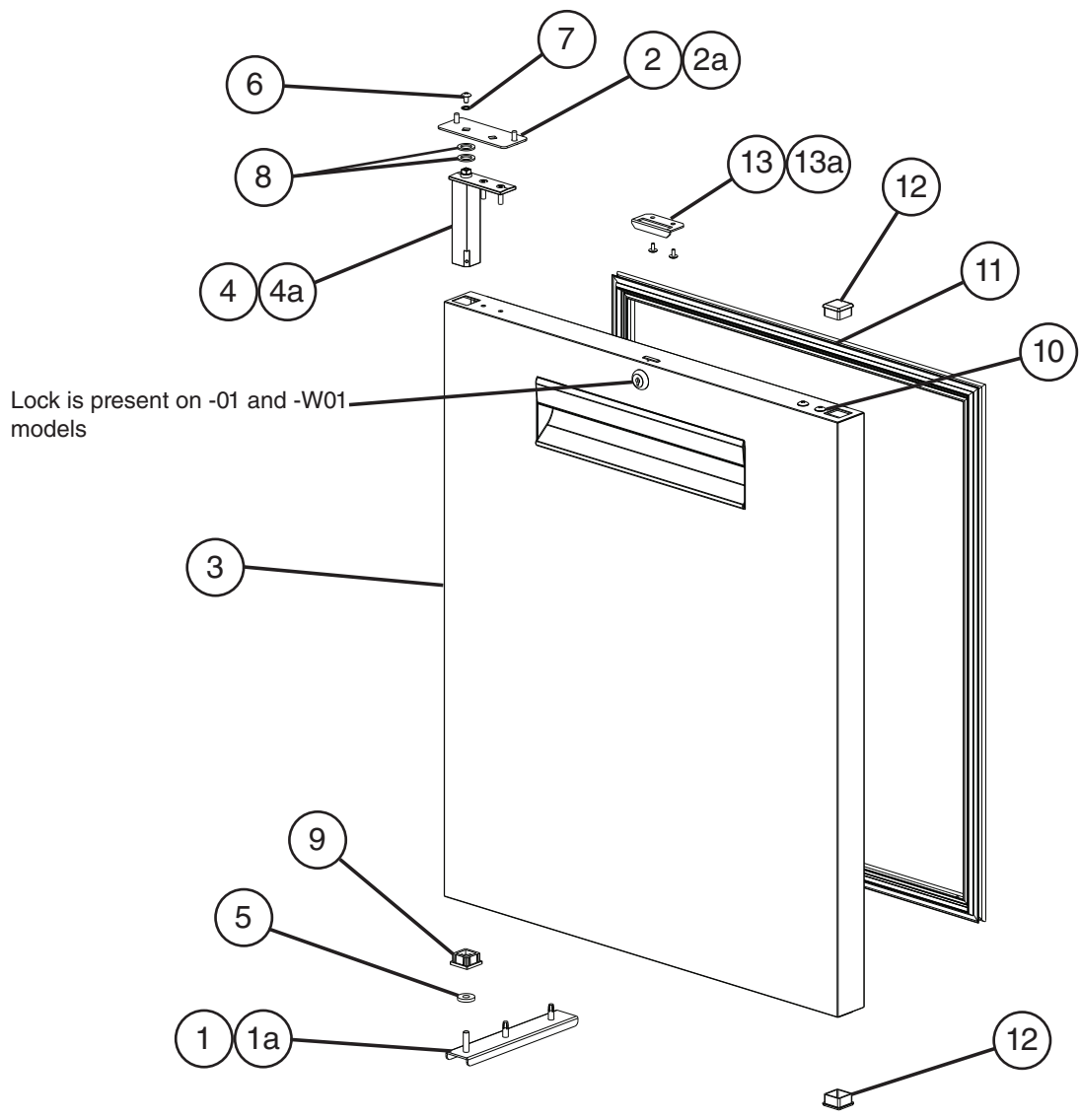

<b>Title: D. Door-Left Hinged Models: Undercounter, Worktop, Prep Table</b>											
Index No.	Description	Material or Model Number	Part Number	Required Number							
				A-5 to D-6 (D)	D-6 (E) to G-5	G-6 H-5					
1	Lower Hinge Bracket		3A6681G01	1	1	1					
1a	Hex Head Tapping Bolt	1/4-20x3/4	4A5213-01	2	2	2					
2	Upper Hinge Bracket		3A6810-01	1	1	1					
2a	Truss Head Screw	5x12, SS	7C32-0512	2	2	2					
3	Door Assembly without Locks (includes items 4 through 12)	<b>CRM_48 and CRMR72 UC/WT/Prep Table (All except -01 and -W01)</b>	2A7325G01	1	1	1					
		<b>CRMR60 UC/WT/Prep Table (All except -01 and -W01)</b>	2A7329G01	1	1	1					
	Door Assembly with Locks (includes items 4 through 12)	<b>CRM_48-01(-W01) and CRMR72-01(-W01) UC/WT/Prep Table</b>	2A7326G01	1	1	1					
4	Hinge Spring Cartridge (includes items 5 through 9)		3A9206-01	1	1	1					
4a	Countersunk Screw	5x20, SS	7C42-0520	2	2	2					
5	Thrust Washer		4A5234-01	1	1	1					
6	Screw		4A5230-01	1	1	1					
7	Lockwasher		4A5231-01	1	1	1					
8	Thrust Washer		4A5233-01	2	2	2					
9	Bearing		4A5232-01	1	1	1					
10	Truss Head Screw (filler screws)	5x10, SS	7C32-0510	2	2	2					
11	Gasket	<b>CRM_48 and CRMR72 UC/WT/Prep Table</b>	2A5192-06	1	-						
			2A6996-06		1	1					
		<b>CRM_60 UC/WT/Prep Table</b>	2A5192-09	1	-						
			2A6996-09		1	1					
12	End Cap		4A5432-01	2	2	2					
13	Strike Plate for Doors with Locks	<b>-01(-W01) UC/WT/Prep Table</b>	4A5493-01	1	1	1					
13a	T2 Screw	<b>-01(-W01) UC/WT/Prep Table</b> 4x8, SS	7P32-0408	2	2	2					

## E. Door-Right Glass Door Hinged Undercounter, Worktop, Prep Table

G-5

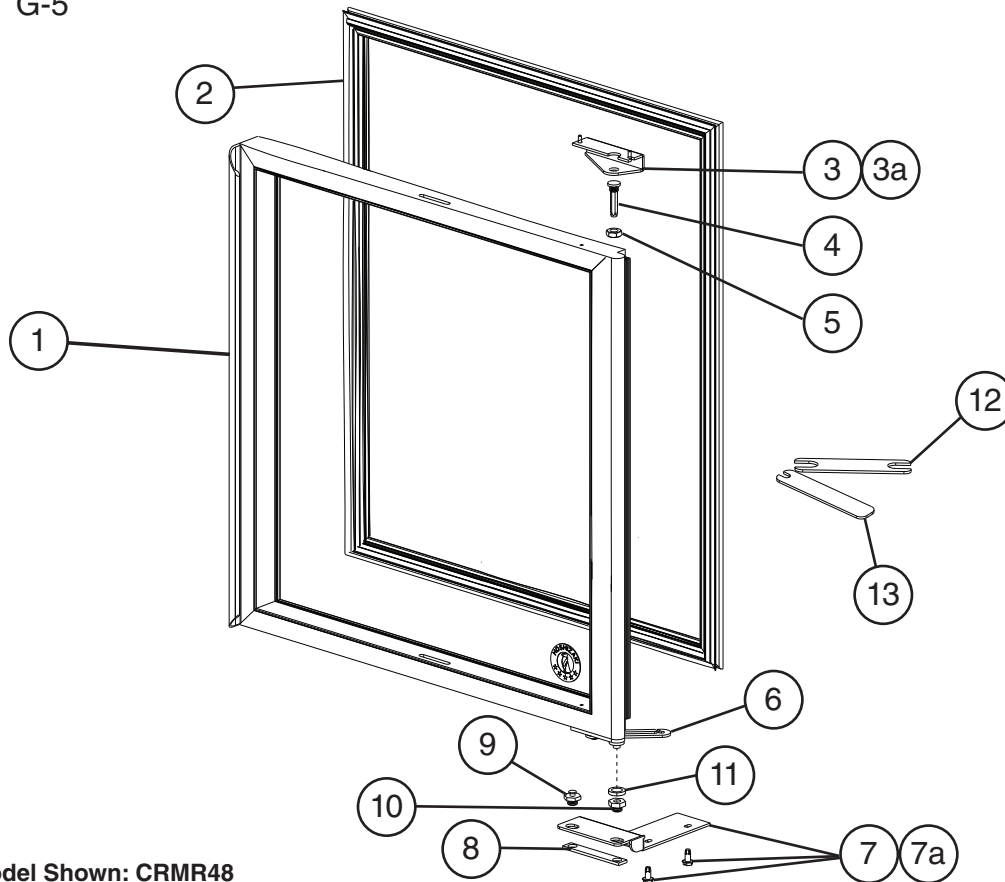

Model Shown: CRMR48

Title: E. Door-Right Glass Door Hinged Models: Undercounter, Worktop, Prep Table															
Index No.	Description	Material or Model Number	Part Number	Required Number											
				G-5											
1	Door (includes gasket and hinge arm)	CRMR27-GLP01	2A8359-03	1											
		CRMR48-GLP01 Right Side Hinged Door	2A8374-03	1											
2	Gasket	CRMR27-GLP01	4A6079-01	1											
		CRMR48-GLP01	4A6079-02	1											
3	Upper Hinge		3A9346-02	1											
3a	Truss Head Screw	5x12, SS	7C32-0512	2											
4	Hinge Pin		3A7946-04	1											
5	Hinge Pin Locknut		3A7946-05	1											
6	Hinge Arm		3A7946-01	1											
7	Lower Hinge		3A9342-01	1											
7a	Hex Head Tapping Bolt	1/4-20x3/4	4A5213-01	2											
8	Backer Plate		3A7946-08	1											
9	Slide Pin		3A7946-11	1											
10	Hinge Bushing		3A7946-09	1											
11	Nylon Washer		3A7946-10	1											
12	Wrench A		3A8298-01	1											
13	Wrench B		3A8299-01	1											

## F. Door-Left Glass Door Hinged Undercounter, Worktop, Prep Table

G-5

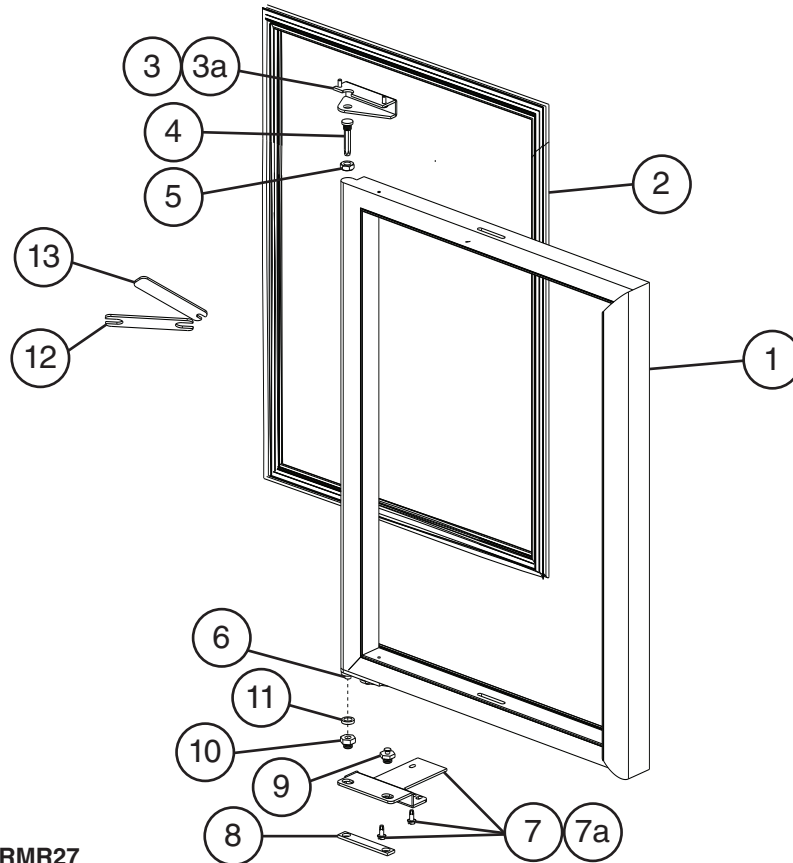

Model Shown: CRMR27

Title: F. Door-Left Glass Door Hinged Models: Undercounter, Worktop, Prep Table

Index No.	Description	Material or Model Number	Part Number	Required Number														
				G-5														
1	Door (includes gasket and hinge arm)	<b>CRMR48-GLP01</b>	2A8374-01	1														
2	Gasket	<b>CRMR48-GLP01</b>	4A6079-02	1														
3	Upper Hinge		3A9346-01	1														
3a	Truss Head Screw	5x12, SS	7C32-0512	2														
4	Hinge Pin		3A7946-04	1														
5	Hinge Pin Locknut		3A7946-05	1														
6	Hinge Arm		3A7946-01	1														
7	Lower Hinge		3A9342-02	1														
7a	Hex Head Tapping Bolt	1/4-20x3/4	4A5213-01	2														
8	Backer Plate		3A7946-08	1														
9	Slide Pin		3A7946-11	1														
10	Hinge Bushing		3A7946-09	1														
11	Nylon Washer		3A7946-10	1														
12	Wrench A		3A8298-01	1														
13	Wrench B		3A8299-01	1														

**G. Drawer**  
**Undercounter, Worktop, Prep Table (-D)(-D2)(-D4)(-D6)**  
 A-5 to H-5

D-6 (J) and Earlier

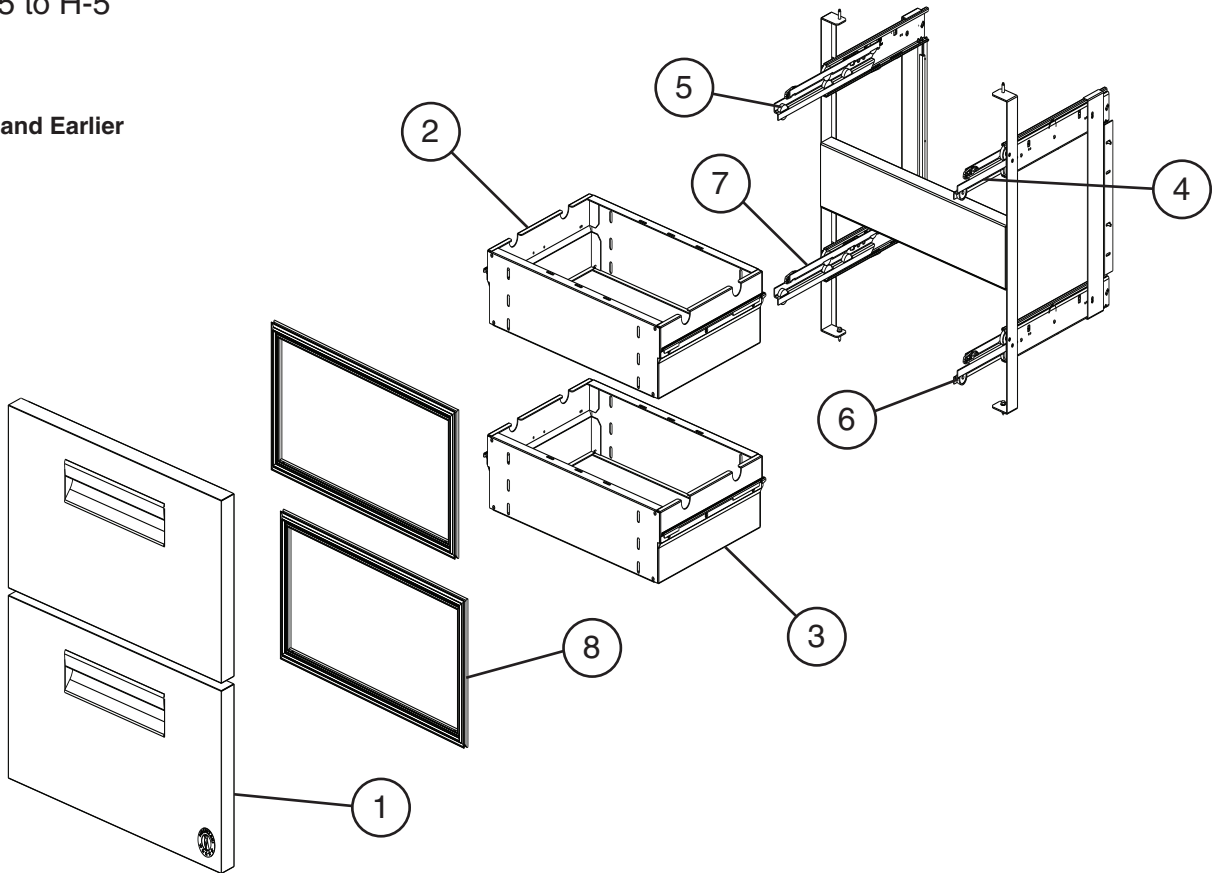

D-6 (K) and Later

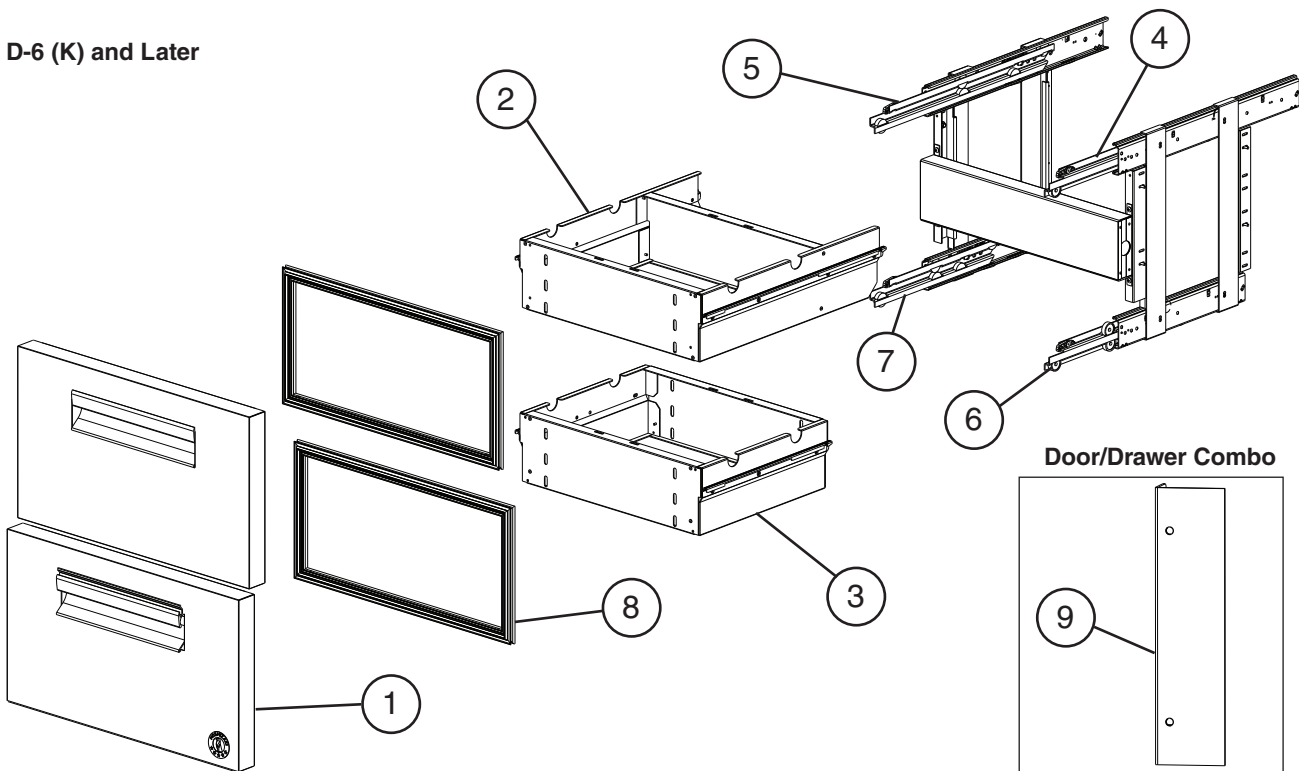

1Title: G. Drawer Models: Undercounter, Worktop, Prep Table											
Index No.	Description	Material or Model Number	Part Number	Required Number							
				A-5 to D-6 (J)	D-6 (K) to G-5	G-6 H-5					
1	Drawer Face	CRM_27-D UC/WT/Prep Table	2A7510G01	2	2	2					
		CRM_48-D(-D_) and CRM_72-D(-D_) UC/WT/Prep Table	2A7511G01	2	2	2					
		CRM_60-D(-D_) UC/WT/Prep Table	2A7512G01	2	2	2					
2	Upper Drawer Box	CRM_27-D UC/WT/Prep Table	3A8185G01	1	-						
			3A8748G01		1	1					
		CRM_48-D(-D_) and CRM_72-D(-D_) UC/WT/Prep Table	3A8191G01	1	-						
			3A8747G01		1	1					
		CRM_60-D(-D_) UC/WT/Prep Table	3A8294G01	1	-						
		3A8718G01		1	1						
3	Lower Drawer Box	CRM_27-D UC/WT/Prep Table	3A8185G01	1	1	1					
		CRM_48-D(-D_) and CRM_72-D(-D_) UC/WT/Prep Table	3A8191G01	1	1	1					
		CRM_60-D(-D_) UC/WT/Prep Table	3A8294G01	1	1	1					
4	Upper Right Slide Roller		4A5663-02	1	-						
			4A5772-02		1	1					
5	Upper Left Slide Roller		4A5664-02	1	-						
			4A5773-02		1	1					
6	Lower Right Slide Roller		4A5663-02	1	1	1					
7	Lower Left Slide Roller		4A5664-02	1	1	1					
8	Gasket	CRM_27-D UC/WT/Prep Table	2A5192-15	2	2	2					
		CRM_48-D(-D_) and CRM_72-D(-D_) UC/WT/Prep Table	2A5192-17	2	2	2					
		CRM_60-D(-D_) UC/WT/Prep Table	2A5192-16	2	2	2					
9	Vertical Mullion Bracket	Door/Drawer Combo	3A8187-01		1	1					

**H. Accessories & Labels**  
**Undercounter, Worktop, Prep Table**  
A-5 to H-5

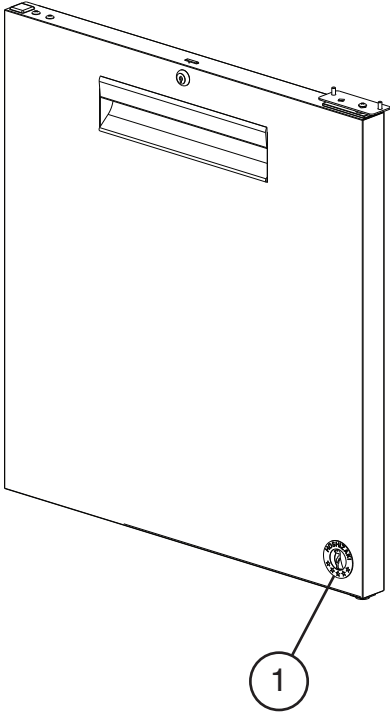
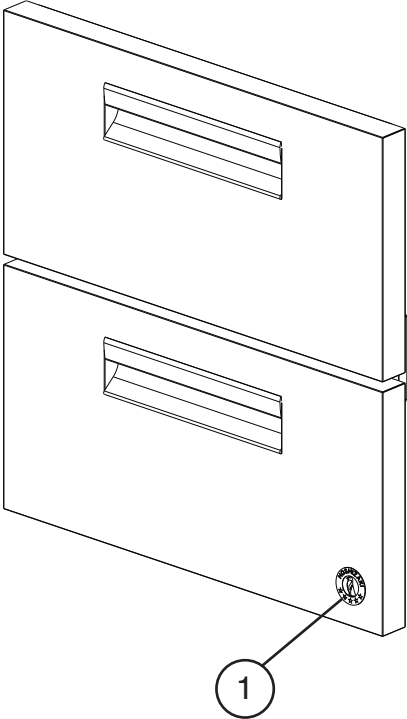



Title: H. Accessories & Labels    Models: Undercounter, Worktop, Prep Table												
Index No.	Description	Material or Model Number	Part Number	Required Number								
				A-5 to D-6 (F)	D-6 (G) to G-5 H-5							
1	Penguin Label		475552L01	1	1	1						
2	4" Caster Kit (includes items 3 and 4)	<b>HS-5035 UC</b>	4A5434A01	1	1	1						
	2" Caster Kit (includes items 3, 4, and 4a)	<b>HS-5037 UC Low Profile</b>	4A5436A01	1	1	1						
	6" Caster Kit (includes items 3 and 4)	<b>HS-5036 WT/Prep Table</b>	4A5435A01	1	1	1						
3	4" Non-Locking Caster	<b>UC</b>	4A5427-01	2	2	2						
	2" Non-Locking Caster	<b>UC Low Profile</b>	4A5429-01	2	2	2						
	6" Non-Locking Caster	<b>WT/Prep Table</b>	4A5428-01	2	2	2						
4	4" Locking Caster	<b>UC</b>	4A5427-02	2	2	2						
	2" Locking Caster	<b>UC Low Profile</b>	4A5429-02	2	2	2						
	6" Locking Caster	<b>WT/Prep Table</b>	4A5428-02	2	2	2						
4a	Wrench	<b>UC Low Profile</b>	4A5492-01	1	1	1						
4b	Caster Bracket	<b>CRM_48(-xxxx) UC/WT/Prep Table</b>	3A8957-01		2	2						
<b>Prep Table Specific Parts</b>												
5	1/6 Size Pan, 4" Depth	<b>-8</b>	1000000344	8	8	8						
		<b>-10</b>			10	10						
		<b>-15M</b>			15	15						
		<b>-12, -12M</b>		12	12	12						
		<b>-18, -18M, 18MD(x)</b>		18	18	18						
		<b>-24M, -24MD2</b>		24	24	24						
		<b>-30M, -30MD(x)</b>		30	30	30						
6	Cutting Board	<b>CRMR27-8</b>	3A4894-09	1	1	1						
		<b>CRMR27-12M</b>	3A4894-07	1	-							
			3A4894-09		1	1						
		<b>CRMR36-10(-15M)</b>	3A4894-15		1	1						
		<b>CRMR48-xx(M)</b>	3A4894-10	1	1	1						
		<b>CRMR60-xx</b>	3A4894-13	1	1	1						
		<b>CRMR60-xxM</b>	3A4894-11	1	-							
			3A4894-13		1	1						
<b>CRMR72-xx(M(Dx))</b>	3A4894-14	1	1	1								