



# HyPerSteam Pressureless Steamer model HY-6SM

### Description

Steamer shall be a direct steam powered Groen HyPLUS Model HY-6SM, stainless steel twin cavity, 6 pan cabinet mounted pressureless steamer, per Bulletin 76Ca and as follows:

### Construction

Steamer cavities and cabinet base shall be all stainless steel construction. Steamer unit shall have a unitized body with removable right side panel providing access to internal components. Steamer doors are all stainless steel with strong continuous hinge and are field reversible for left or right swing. Doors shall be insulated and provided with a one piece, replaceable seal. Easy open handle and latch shall provide positive lock and seal when door is pushed or slammed shut.

Hidden magnetic door switch cuts power to blower and steam flow to that cavity, when the door is opened. Pan support racks shall be polished stainless steel and removable for easy cleaning. Wide drip sink with condensate drain is positioned under cavity doors.

24" wide cabinet base shall have stainless steel frame with all stainless steel top deck, removable access door, with side and rear panels standard. Front and rear legs shall have adjustable bullet feet.

### Finish

Cabinet exterior including doors shall be finished to a #3 uniform finish. Cavity interiors are polished stainless steel. Control panel face plates shall be smudge resistant polyester film, ensuring maximum ease in cleaning and maintaining an attractive appearance.

### UL Listed

Steamer units shall be UL listed.

### Sanitation

Unit shall be designed and constructed to meet NSF and known health department and sanitation codes, and be NSF listed.

### Controls

Steamer cavity controls shall be mounted on the front panel for easy replacement or repair and will include a separate ON-OFF/60 minute timer control with constant steam setting, for each cavity. Cabinet mounted power-ON switch shall activate steamer electronics.

### Performance Features

Each steamer cavity shall have a powerful side mounted blower, which increases steam velocity and provides efficient steam distribution throughout cavity and between loaded pans.

### Remote Steam Source

HY-6SM requires food safe steam delivered at a minimum of 52 lbs. per hr., at a maximum working pressure of 15 PSI. Operator must verify steam doesn't contain caustic boiler cleaning compounds or contaminants unsuitable for direct contact with food.



### Pan Capacity

Pan Size	Per Cavity	Number
12 x 20 x 1"	6	12
12 x 20 x 2 1/2"	3	6
12 x 20 x 4"	2	4

### Installation

Unit requires steam connection via 1/2" NPT pipe. Unit requires 3/8" NPT cold water supply line, 1 1/4" NPT free venting drain; and 115 volt, single phase, 60 cycle 15 AMP electric service, 4 AMP maximum load.

### Water Supply Requirements

To minimize service problems, a water treatment (softening) system is recommended when water quality is found to exceed limits stated below and in operator manual. Recommended MINIMUM water quality standards are: Total dissolved solids (TDS) content should not exceed 30 parts per million, and the water pH should be 7.0 or higher.

### Options/Accessories

- Flanged mounting feet

### Origin of Manufacture

Kettle shall be designed and manufactured in the United States.

**6 Pan Capacity  
Stainless Steel  
Pressureless Steamer**

**Direct Steam  
Powered  
(Remote Source)  
On Cabinet Base**

### Short Form

Unit shall be a Groen HyPLUS pressureless steamer Model HY-6SM, designed for operation with remote source food safe direct steam and mounted on 24" wide cabinet base, per Bulletin 76Ca. All stainless steel construction with two independent steamer chambers, each with powerful blower to circulate steam within cavity and individual 60 minute timer with constant steam setting. Doors are insulated, field reversible, with easy open latch and hidden magnetic door switch. Drip sink with condensate drain is provided under cavity doors. Three (2 1/2" deep) pan capacity per chamber. Cabinet base has stainless steel frame, all stainless steel exterior with removable access door and adjustable bullet feet. See other side for water, drain, electric and steam connections required. Made in U.S.A.



### Applications

- Pasta
- Rice
- Vegetables (Fresh & Frozen)
- Seafood (Fresh & Frozen)
- Poultry
- Potatoes
- Eggs
- Meats
- Reheat Cook-Chill & Prepared Foods

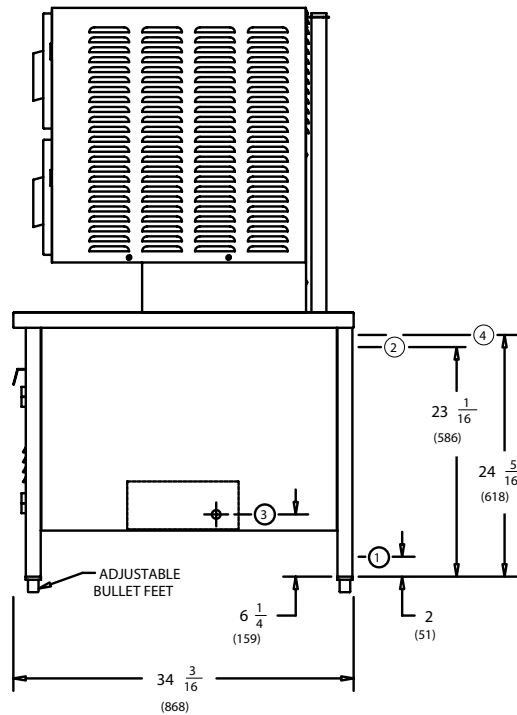
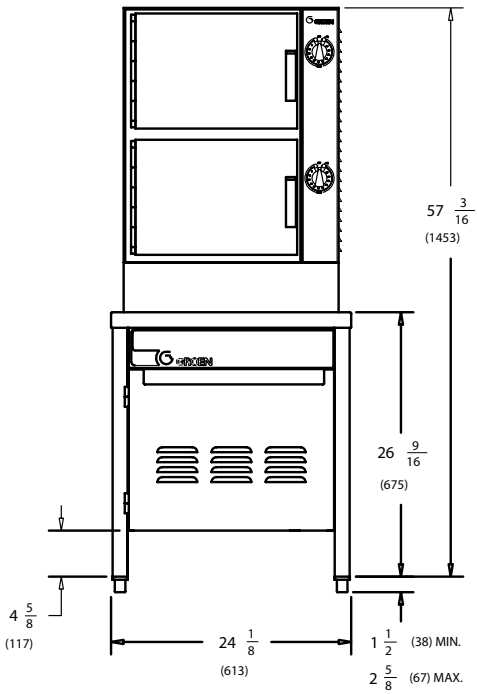
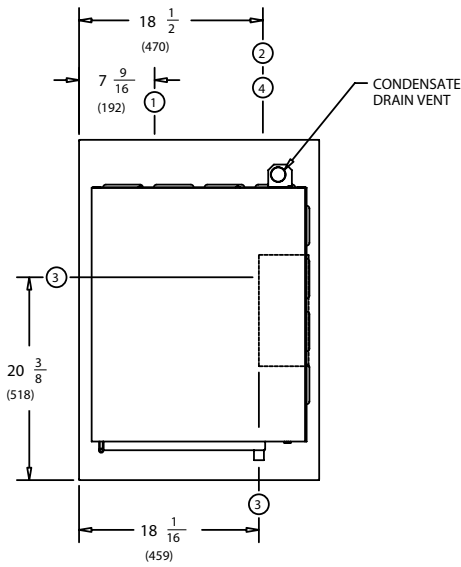
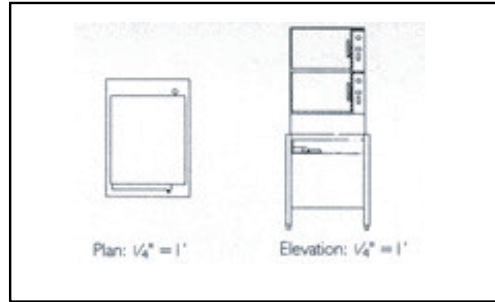

DIMENSIONS: INCHES (MILLIMETERS)

**SERVICE CONNECTIONS:**

- ① DRAIN CONNECTION: 1-1/4" NPT (INCLUDES STEAMERS, & CONDENSATE SPRAY)
- ② COLD WATER SUPPLY: 3/8" NPT (FOR CONDENSATE SPRAY)
- ③ ELECTRICAL CONNECTION: 7/8" DIA. HOLE (REF. 1/2" CONDUIT KNOCK-OUT)
- ④ STEAM CONNECTION: 1/2" NPT - 52 LBS/HR (MIN.) @ 15 PSI (MAX.)

NOTE: STEAM MUST BE "CLEAN" AND SUITABLE FOR FOOD CONTACT.

