

GRIPIT® STANDARD & EXPANDO GRIPIT® TOOL HOLDERS

Gripit® and Expando Gripit® Tool Holders provide convenient wall storage for tools with handles up to 2" in diameter.

- Standard Gripit® is designed for mops, brooms, hammers and other tools with handle diameters up to 1 3/16".
- Expando Gripit® holds heavier tools such as hoses, shovels, and vacuum wands with handles up to 2" in diameter.

FEATURES

- High impact plastic construction is strong, durable, rustproof.
- Tools can be hung head up or head down without slipping.
- Multiple Gripits, Expando Gripits, and Utility Hooks can be moved on the mounting bars to tailor storage space to specific tools.
- Mounting holes allow individual Gripit® or Expando Gripit® tool holders to be mounted directly to the wall.
- Track mounting holes on the mounting bars are 16" on center for convenient attachment to wall studs.
- Proudly made in the USA

Installed on any wall in minutes, Gripit® saves time, ends clutter, and makes it easy to find tools fast. Designed for mops, brooms, hammers and other tools. Simply push the tool handle against Gripit®, and the roller, with a high friction surface, automatically adjusts to lock it securely. To remove the tool, lift the handle slightly and it's free.



Gripit® Standard Tool Holder
Holds Handle Diameters Up To 1 3/16"

MODEL #5045



Expando Gripit® Tool Holder
Holds Handle Diameters Up To 2"

MODEL #5030

GRIPIT® STANDARD & GRIPIT® EXPANDO TOOL HOLDERS

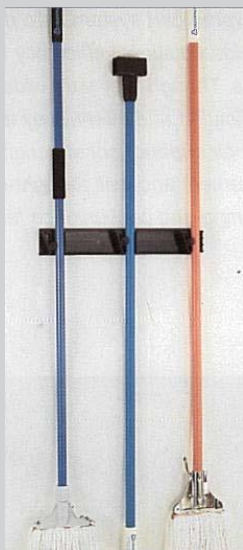

MODEL #5047

Tools Can Be Hung Head Up Or Head Down Without Slipping

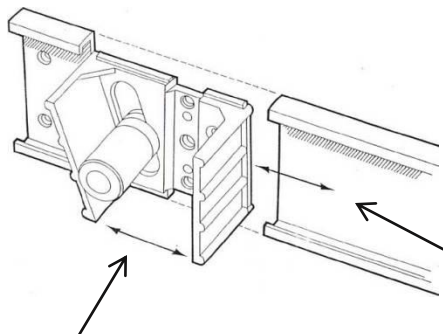

Expando Gripit® Can Be Adjusted To 3 Positions.

Gripit® and Expando Gripit® can be moved in the track to tailor storage area to specific tools



MODEL #5038

Gripit® System With 34" Mounting Bar Includes:

2 Each Gripits, Expando Gripits, Short and Long Utility Hooks.

Gripit® Standard Tool Holders (For Handle Diameters Up To 1 3/16")

Model #	Description	Case Pack
5045	Gripit® Carton Of 6 Ea.	Case
5046	Gripit® Master Carton, 12 Cartons Of 6 Each	Case
5047	Three Gripits On 18" Mounting Bar, 12 Bars Per Carton	Case
5043	Three Gripits On 18" Mounting Bar In Display Pack, 12 Bars Per Carton	Case
5044	Two Gripits Per Blister Pack, 24 Packs Per Carton	Case

Expando Gripit® Tool Holders (For Handle Diameters Up To 2")

Model #	Description	Case Pack
5030	Expando Gripit® Carton Of 6 Ea.	Case
5031	Expando Gripit® Master Carton, 12 Cartons Of 6 Each	Case
5032	Three Expando Gripits on 18" Mounting Bar 12 Bars Per Carton	Case
5033	Three Expando Gripits On 18" Mounting Bar In Display Pack, 12 Bars Per Carton	Case
5034	Two Expando Gripits Per Blister Pack, 24 Packs Per Carton	Case

Utility Hooks

5050	Plastic Utility Hooks – Short (Pack Of 12)	Dozen
5051	Plastic Utility Hooks – Long (Pack Of 12)	Dozen

Gripit® System

5038	34" Mounting Bar With 2 Each. Gripits, Expando Gripits, Short And Long Utility Hooks	Each
------	--	------

Product ID# 5045/0514



1780 Harvey St., Muskegon, MI 49442 • ph: 800.253.0373 • fax: 231.773.8263 • email: sales@geerpres.com • www.geerpres.com