

DURATHERM™ INDUCTION CHARGER

DX1411 series
INDUCTION BASE



Application

The Ideal Induction Charging System for tray line meal delivery systems which delivers 4 trays per minute and can be used for room service applications. The charging cycle of a DX1411 base is 15 seconds and 10 seconds for a DX821 base at nominal voltage.

Construction

The charger is constructed with the main body of stainless steel and a heavy duty composite surface. The charger is equipped with a microprocessor that performs unique automatic standby/shut-off functions, self diagnostics and incorporates a proprietary automatic sensor for use with Dinex® Induction Bases. A visible Information Center displays the portion of the charge that has been completed, user prompts, operational status and trouble conditions.

Standard Features

- Countertop design, stainless steel housing, heavy duty electronic components, and composite material top, engineered for use in commercial kitchens.
- User-friendly power control.
- A visible display using LCD technology Information Center and an audible alert.
- Automatic standby/shut-off feature.
- Easy-to-clean composite top surface.
- Integral cooling fan keeps internal electronics cool.
- 208V 3-Phase base cycle time approx. 15 seconds. Note: Fluctuation in voltage may effect heating cycle time.
- Space efficient 15.3"x 20.6".
- Washable filter.
- Internal surge protection.
- Twist lock plug- NEMA L15-20P.

Item Numbers

Duratherm Induction Charger

DXDUR2083 (208V) 3-Phase

Bases for Induction System

- DX1411003 - Onyx
- DX1411050 - Midnight Blue
- DX1411061 - Cranberry
- DX1411084 - Sage
- DX1411031 - Latte
- DX1411044 - Graphite

Drying & Storage Racks For Induction Bases

- DXIBDRS90 - Holds 90 Induction Bases
- DXIBDRS180 - Holds 180 Induction Bases
- DXIBDRS270 - Holds 270 Induction Bases

Replacement Cradle for Storage Rack

DX10251

Duratherm System

- Senses both, Dinex Duratherm base DX1411 series, and SmarTherm base DX821 series, automatically and gives the correct amount of energy to get correct temperature every time.
- Microprocessor monitors vital components and runs a performance check on average of 120 times per second. Charger shuts off automatically and displays "trouble codes" codes in plain text enabling user to diagnose or identify minor problems.
- Uses new, durable Dinex Induction Bases

Warranty

Two years parts and labor.

We do not accept returns on any Dinex equipment or Dinex custom products. Please contact your local Dinex rep to ensure order accuracy prior to ordering.

DINEX®

4711 E Hefner Road
Oklahoma City, OK 73131
800.654.8210 | 405.475.5600
www.dinex.com

Duratherm INDUCTION CHARGER

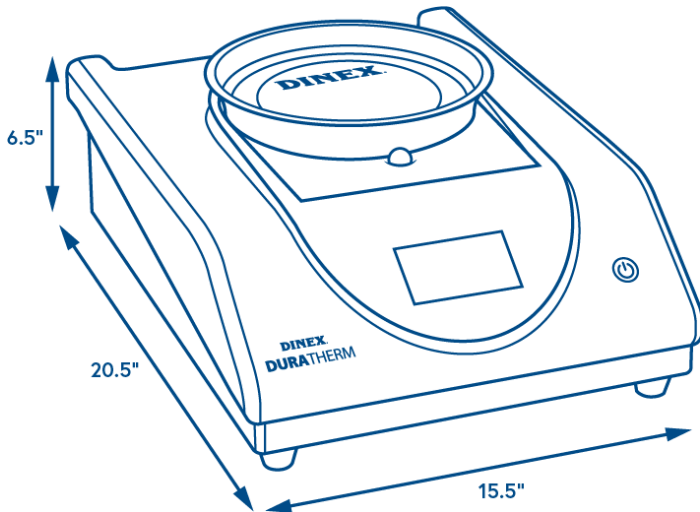

Nema L15-20P



Specifications

Item Number	Model Number	Overall Size			Electrical Specifications				Shipping Specs	
		W	D	H	Volts	AMPS	Watt	NEMA Number	Ship Weight	Ship Cube
DXDUR2083	DXDUR2083	15.5" (39.3cm)	20.5" (52.3cm)	6.5" (16.5cm)	208V 3-Phase	20	6700	L15-20P	29.8 lb.	2.61

Please confirm that you have the most current specification sheet by visiting www.dinex.com.
 Dinex® reserves the right to change specifications and product design without notice.
 Such revisions do not entitle the buyer to corresponding changes, improvements, additions or replacements for previously purchased equipment.

DINEX®

4711 E Hefner Road
 Oklahoma City, OK 73131
 800.654.8210 | 405.475.5600
www.dinex.com