

INSULATED STAINLESS STEEL HOT CABINET MODEL H-138-S-1816C

FEATURES AND BENEFITS:

- Fully insulated 1/2 size hot cabinet keeps prepared foods at serving temperatures.
- Powerful, yet efficient, 1000 Watt heating system maintains the right temperature to properly hold products. Heats up to 200°F (93°C).
- Self-contained power top allows interior of cabinet to be hosed-out during cleaning.
- Internal frame in body maintains structural rigidity.
- 304 stainless steel construction throughout for ease of cleaning. One piece extended base protects cabinet body.
- Smooth interior covered corners prevent food particles/grease buildup.
- Safety-conscious anti-microbial latch protect against spreading germs.
- Field reversible insulated door prevents temperature loss. Silicone door gasket for proper seal.
- Standard with right hand hinging; left hand hinging available upon request.
- High temperature ceramic magnetic latch for "easy open"; twist-lock catch secures door during transport. Latches and hinges mounted inboard.
- Channel pan slides securely hold 18" x 26" pans on 1-1/2" centers without tipping.
- Cabinets can be stacked for flexibility; specify optional stacking kit.
- Heavy duty 5" swivel casters, two with brakes. Provides mobility when fully loaded.



H-138-S-1816C



ACCESSORIES and OPTIONS (Available at extra cost):

- Lock Hasp
- Key Lock Handle
- Stacking Kit
- Tempered Glass Door Window
- Corner Bumpers
- Perimeter Bumper
- Floor Lock (for use with 5" casters)
- Various Caster Options
- Removable Cord Set
- 208 or 240 Volt Service
- Food Safe Digital Thermometer

See page B-20 for accessory details.

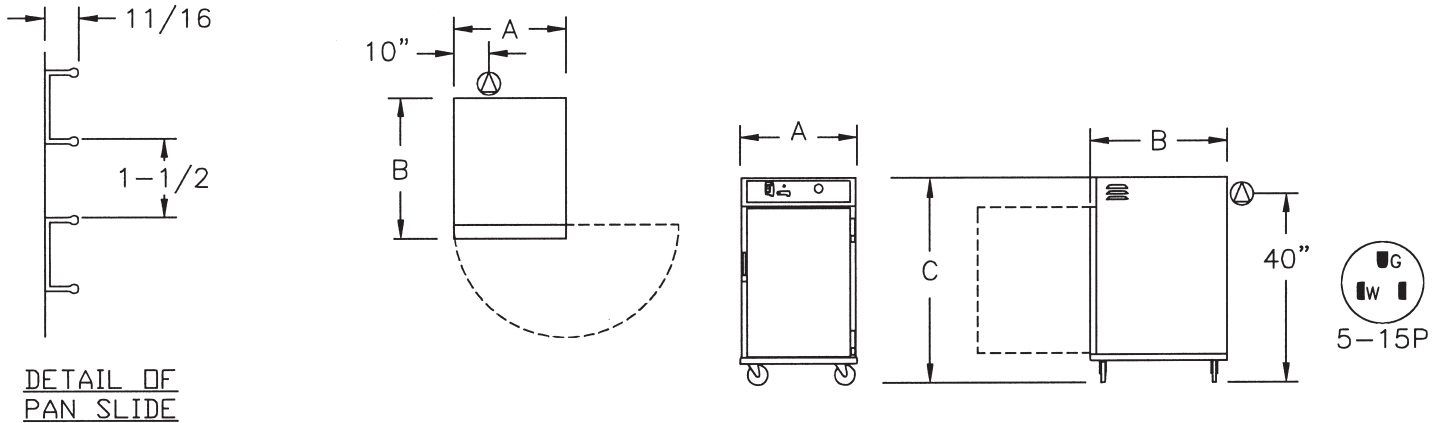

DETAIL OF PAN SLIDE

CRES COR MODEL NO.	PAN			DIM "A"	DIM "B"	DIM "C"	INSIDE DIMENSIONS			WEIGHT ACT.	
	CAP	SIZE					WIDTH	DEPTH	HEIGHT		WIDTH
H-138-S-1816C	16	18 X 26	IN	28-3/4	34-3/16	43	18-1/16	27-1/2	28	LBS	173
		460 X 660	MM	730	870	1095	460	700	715	KG	78

NOTES: 1. Send sample pan or tray with order when using any that are not 18" x 26" pans with heavy beaded edges.
2. When ordering bumpers, add 2" to overall dimensions.

ALL CONSTRUCTION IS RIVETED, WELDED AND FINISHED.

CABINET:

- Body: 22 ga. 304 stainless steel.
- Reinforcement: Internal framework of 18 ga. 304 stainless steel.
- Insulation: Fiberglass, thermal conductivity (K factor) is .23 at 75°F. 1-1/2" in doors, top, base; 2" in sidewalls.
- Air tunnel: 22 ga. 304 stainless steel; lift-out type, mounted on back.
- Push/pull handles (2): 5" vertical; recessed.
- Interior coved corners.

BASE:

- One piece construction, .125 aluminum.
- Casters: 5" dia., swivel, modulus tires, 1-1/4 wide, load cap. 250 lbs. each, temp. range -45°/+180°F. Delrin bearings. Front casters equipped with brakes.

DOORS:

- Field reversible.
- Formed 22 ga. 304 stainless steel.
- Latches: Chrome plated steel, high temperature ceramic magnetic type, mounted inboard.
- Transport Latch.
- Hinges: Heavy duty chrome plated steel.
- Gaskets: Perimeter type, silicone.
- Pan stop: Embossed.

PAN SLIDES:

- Channels: Extruded aluminum, 11/16 x 1-1/2 x .100, riveted on 1-1/2" centers.

HOT UNIT COMPONENTS:

- Top mounted; removable with tools.
- Thermostat: Mechanical, room ambient to 200°F (93°C).
- Switch: ON-OFF rocker type.
- Power light
- Power cord: Permanent, 10 ft., 14/3 ga.
- Heater: 1000 Watts.
- Blower motor.
- Vent fan.
- Thermometer: Analog.

POWER REQUIREMENTS:

- 1000 Watts, 120 Volts, 60 Hz., single phase, 8 Amps., 15 Amp. service.

SHORT FORM SPECIFICATIONS

Cres Cor Insulated Hot Cabinet Model H-138-S-1816C. Cabinet 22 ga. 304 stainless steel; stainless steel internal frame. No-tip .100 aluminum channel slides for (16) 18" x 26" pans on 1-1/2" centers. Field reversible door, 22 ga. 304 stainless steel. Fiberglass insulation in sides 2"; door, top, base 1-1/2". Interior coved corners. Hose out cleaning capability. 1000 Watt, 120 Volt power unit. One piece insulated base, .125 aluminum. 5" swivel modulus casters, Delrin bearings. Load capacity 250 lbs. each. 2 year parts warranty. Provide the following accessories: _____ . NSF, CSA-US, CSA-C, Energy Star Qualified.



5925 Heisley Road • Mentor, OH 44060-1833
Phone: 877/CRESCOR • Fax: 440/350-7267
www.crescor.com

© Crescent Metal Products, Inc. 2008 All rights reserved.

In line with its policy to continually improve its products, CRES COR reserves the right to change materials and specifications without notice.

Litho in U.S.A.