

Service & Parts Manual

Convotherm Combination Oven-Steamer

MODELS: Gas 20.20



OGS-20.20



OGB-20.20



Enodis

1333 East 179th St., Cleveland, Ohio, U.S.A. 44110

Phone: (216) 481-4900 Fax: (216) 481-3782
Visit our web site at www.clevelandrange.com

2020 GAS GENERATOR W CLEANING

Washer Arm C2611184

Spray Handle Shut Off Valve
C6014003

Light Gasket C6015020

Lamp C5005043

Condensate Box o-ring C6015000

Spray Handle Bracket
C2002042

C2004035- Mounting
Disc

C8001026- Bushing

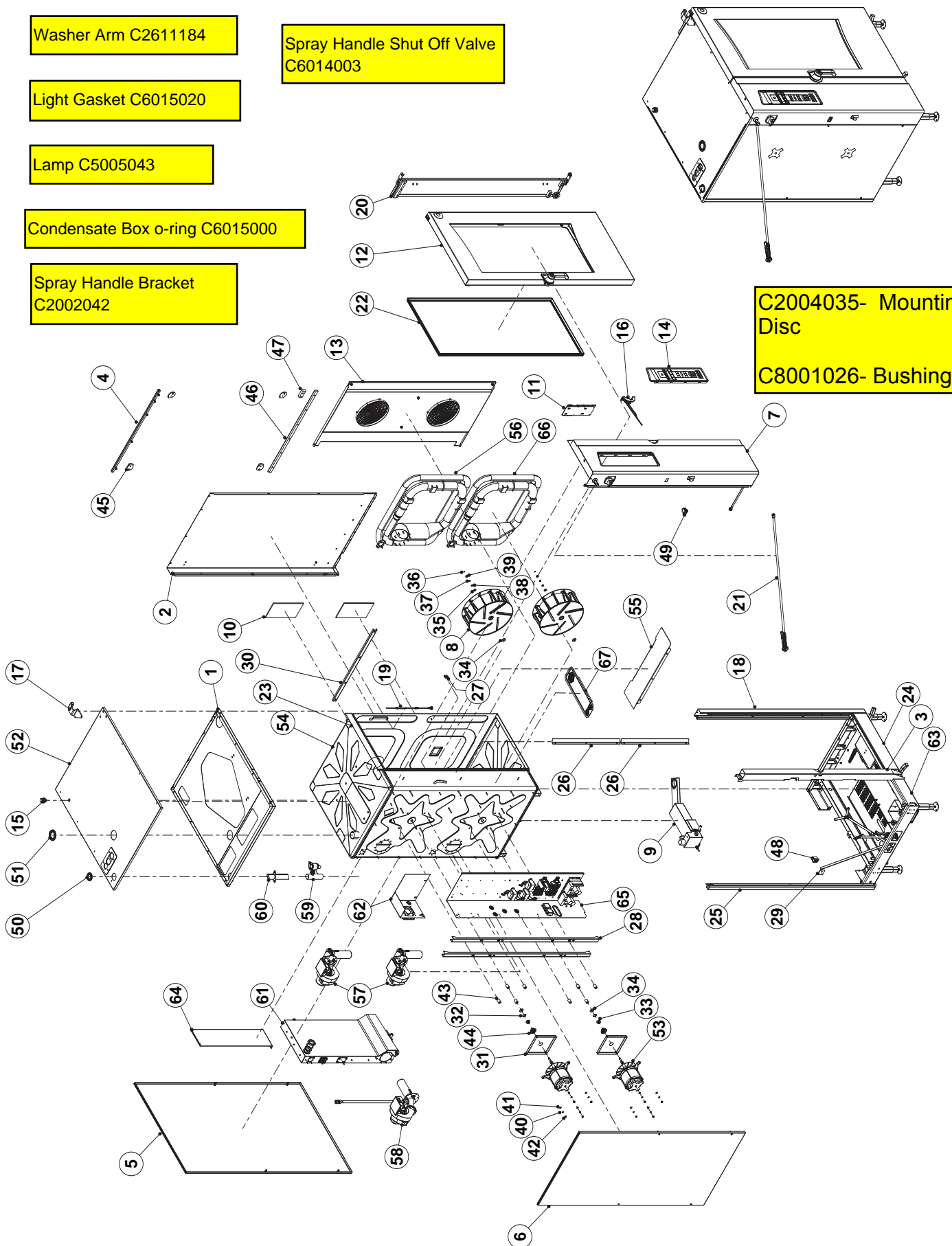

2020 GAS GENERATOR W CLEANING

ITEM	QTY	PART NO.	DESCRIPTION
1	1	C2114828	ASSEMBLY/WELDMENT, TOP, INTERMEDIATE, 12.20/20.20
2	1	C2115487	ASSEMBLY, PANEL, RIGHT SIDE, 20.20
3	1	C2114721	WELDMENT, REINFORCEMENT, DOOR LATCH, 20.10/20.20
4	1	C2114690	ASSEMBLY, SLIDE BAR, DISAPPEARING DOOR, X.20
5	1	C2114747	ASSEMBLY, PANEL, REAR, ELECTRIC & GAS INJECTOR, 20.20
6	1	C2114787	ASSEMBLY, PANEL, LEFT SIDE, 20.20
7	1	C2115447	ASSEMBLY, CORNER, FRONT LEFT, 20.20
8	2	C6010003	WHEEL, BLOWER, 405mm OD X 150mm WIDE, TYPE 304 SST, 20.20 COMBI
9	1	C2012107	ASSEMBLY, CONDENSER, FLOOR UNIT,
10	2	C2614841	CAVITY LIGHT,
11	1	C26142661	ASSEMBLY, CONTROLLER
12	1	C2514356	ASSEMBLY, DOOR, 20.20,
13	1	C2214147	ASSEMBLY, INTAKE PLATE STEAM GENERATOR 20.20
14	1	C2114296	ASSY, CONTROL PANEL, STEAM GEN, WITH PICTO
15	1	109641	PORT ASSY, DESCALER
16	1	C2216070	ASSEMBLED, BLOCK
17	1	C2614750	ASSEMBLY, GUIDE CLIP, VST, FLOOR MODEL,
18	1	C2115493	ASSEMBLY, CORNER, FRONT, RIGHT, 20.20
19	1	C26142631	ASSEMBLY, CORE TEMPERATURE SENSOR, 20.20,
20	1	C26148301	FINAL ASSEMBLY, DISAPPEARING DOOR, X.20,
21	1	C22160803	ASSEMBLY, HAND SHOWER
22	1	C7011007	DOOR SEAL, 20.20
23	1	C2114732	FACEPLATE, UPPER X.20
24	1	C2114730	FACEPLATE, LOWER, 12.20/20.20
25	1	C2114636	CORNER, WELDED, REAR LEFT 20.10/20.20
26	2	C2216467	PLATE, AIR GUIDE, FLOW
27	1	C2016009	COVER, BYPASS,
28	2	C2614735	MOTOR STIFFENER, 20.10/20.20
29	1	C2114798	BRACKET, HIGH LIMIT, STEAM GENERATOR,
30	1	C2216797	STIFFENER, INNER CAVITY, RIGHT SIDE 20.20
31	2	C2114140	MOTOR MOUNTING PLATE
32	2	C6015210	SHIM, WEARING MOTOR SHAFT SEAL
33	2	C6015206	BUSHING, LABYRINTH
34	4	C6015021	SEALING RING, MOTOR SHAFT, VITON, COMBI
35	2	111544	WASHER, BELLEVILLE, M10, SMOOTH, TYPE 301 SST, 10.21mm ID X 24mm OD X 1.85mm THICK
36	2	111543	RING, RETAINING, EXTERNAL, 1/4", STAINLESS STEEL, WALDES #5100-25H
37	2	111542	WASHER, BELLEVILLE, M8, SERRATED BOTH SIDES, SST, 8.4mm ID X 13mm OD X 0.8mm THICK
38	2	111541	NUT, HEX, LEFT-HAND, M8 X 1.25 (DIN 934L), STAINLESS STEEL
39	2	111540	NUT, HEX, M10 X 1.5 (DIN 934), STAINLESS STEEL
40	8	C8006060	SCHNORR LOCK WASHER
41	8	C8005050	WASHER, 8.4 A2 DIN 125
42	8	C8004057	NUT, HEX, M8 A4
43	8	C6015213	SPACER, MOTOR 1.299 (FAN DISTANCE 2.008in)
44	2	C6015050	SPRING, MOTOR SHAFT SEAL
45	4	C6012011	DOORSTOPPER VA VST
46	1	C2017000	SAFETY RAIL, VST, X.20
47	1	C6012009	GUIDE STRIP, LOWER VST
48	1	C5001041	SAFETY TEMPERATURE LIMITER, 340°C
49	1	19993	SWITCH, ROCKER, DPDT, ON/OFF 15A, 125V
50	1	C6005048	DIAPHRAGM GROMMET ø 60 mm (DG 48) P2
51	1	C6005427	DIAPHRAGM GROMMET ø 83 (DG60) FOR VAC. REG. VALVE
52	1	C2115467	ASSEMBLY, PANEL, TOP, GAS GEN, 20.20
53	2	C50180221	MOTOR W/STUD, ALL VOLTAGES, 3-PHASE, 4 POLE, 0.9KW, GAS COMBI
54	1	C2215106	INNER HOUSING, GAS, GEN, 20.20, REI, KTM
55	1	C2214139	WELDMENT, AIR GUIDE, FAN SPACE, 20.20, GAS
56	1	C2010016	WELDMENT, HEAT EXCHANGER 10.20/12.20/20.20
57	2	C2614863	BURNER INSERT, HOT AIR, 110V, 10.20/12.20/20.20, NAT
58	1	C2314903	ASSY, BURNER INSERT, GEN, GAS, 10.20/12.20/20.10/20.20, NAT
59	1	C21142872	ASSY, AIR OUTLET 20.20 GEN.
60	1	C2114292	AIR OUTLET CONECTING PIECE 20.20 GEN. 6.20/10.10/20.20 INJ.
61	1	C2314883	GEN, GAS, PRE-MOUNTED, 10.20/20.10/20.20
62	1	C5115949	ASSEMBLY, EXTENSION, MOUNTING PLATE, GAS, 20.20,
63	1	C21145492	BASE W/COVER, RAILS, ETC, W/CLEAN
64	1	C2314244	SUSPENSION, STEAM GEN, 20.10/20.20
65	1	300504	ASSEMBLY, COMPONENT PANEL, OGB 20.20
66	1	C2010090	WELDMENT, HEAT EXCHANGER, LOWER, 20.20
67	1	C2216796	ASSEMBLY, COVER, DEHUMIDIFYING GUTTER

2020 GAS INJ W CLEANING

Washer Arm C2611184

Spray Handle Shut Off Valve
C6014003

light Gasket C6015020

Lamp C5005043

Condensate Box o-ring C6015000

Spray Handle Bracket
C2002042

C2004035- Mounting
Disc
C8001026- Bushing

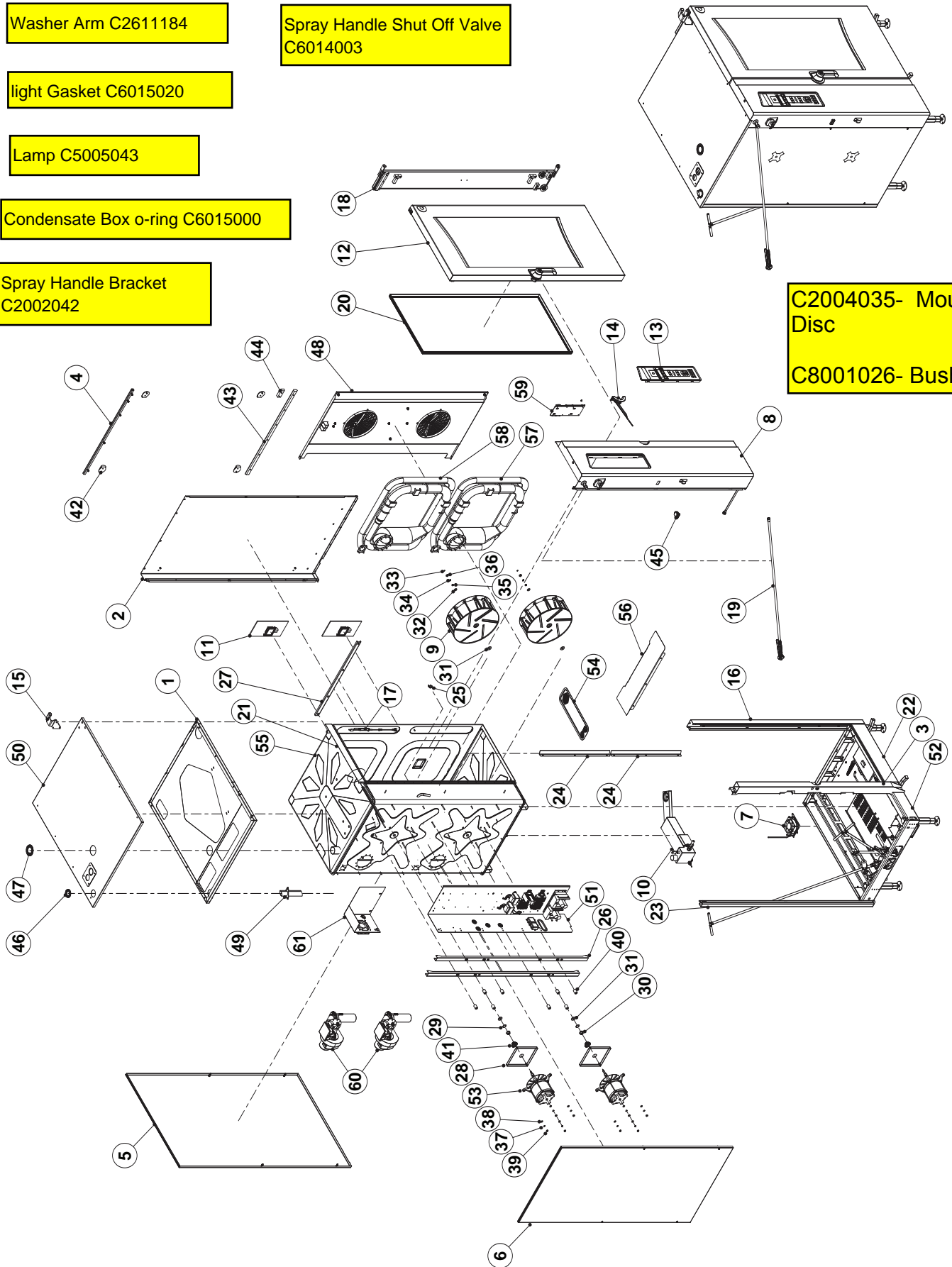

2020 GAS INJ W CLEANING

ITEM	QTY	PART NO.	DESCRIPTION
1	1	C2114828	ASSEMBLY/WELDMENT, TOP, INTERMEDIATE, 12.20/20.20
2	1	C2115487	ASSEMBLY, PANEL, RIGHT SIDE, 20.20
3	1	C2114721	WELDMENT, REINFORCEMENT, DOOR LATCH, 20.10/20.20
4	1	C2114690	ASSEMBLY, SLIDE BAR, DISAPPEARING DOOR, X.20
5	1	C2114747	ASSEMBLY, PANEL, REAR, ELECTRIC & GAS INJECTOR, 20.20
6	1	C2114787	ASSEMBLY, PANEL, LEFT SIDE, 20.20
7	1	C2216090	FAN, AIR INLET BOX ASSEMBLY
8	1	C2115447	ASSEMBLY, CORNER, FRONT LEFT, 20.20
9	2	C6010003	WHEEL, BLOWER, 405mm OD X 150mm WIDE, TYPE 304 SST, 20.20 COMBI
10	1	C2012107	ASSEMBLY, CONDENSER, FLOOR UNIT
11	2	C2614841	CAVITY LIGHT
12	1	C2514356	ASSEMBLY, DOOR, 20.20
13	1	C2114296-3	ASSY, CONTROL PANEL, SPRITZER, WITH PICTO
14	1	C2216070	ASSEMBLED, BLOCK
15	1	C2614750	ASSEMBLY, GUIDE CLIP, VST, FLOOR MODEL
16	1	C2115493	ASSEMBLY, CORNER, FRONT, RIGHT, 20.20
17	1	C26142631	ASSEMBLY, CORE TEMPERATURE SENSOR, 20.20
18	1	C26148301	FINAL ASSEMBLY, DISAPPEARING DOOR, X.20
19	1	C22160803	ASSEMBLY, HAND SHOWER
20	1	C7011007	DOOR SEAL, 20.20
21	1	C2114732	FACEPLATE, UPPER X.20
22	1	C2114730	FACEPLATE, LOWER, 12.20/20.20
23	1	C2114636	CORNER, WELDED, REAR LEFT 20.10/20.20
24	2	C2216467	PLATE, AIR GUIDE, FLOW
25	1	C2016009	COVER, BYPASS
26	2	C2614735	MOTOR STIFFENER, 20.10/20.20
27	1	C2216797	STIFFENER, INNER CAVITY, RIGHT SIDE 20.20
28	2	C2114140	MOTOR MOUNTING PLATE
29	2	C6015210	SHIM, WEARING MOTOR SHAFT SEAL
30	2	C6015206	BUSHING, LABYRINTH
31	4	C6015021	SEALING RING, MOTOR SHAFT, VITON, COMBI
32	2	111544	WASHER, BELLEVILLE, M10, SMOOTH, TYPE 301 SST, 10.21mm ID X 24mm OD X 1.85mm THICK
33	2	111543	RING, RETAINING, EXTERNAL, 1/4", STAINLESS STEEL, WALDES #5100-25H
34	2	111542	WASHER, BELLEVILLE, M8, SERRATED BOTH SIDES, SST, 8.4mm ID X 13mm OD X 0.8mm THICK
35	2	111541	NUT, HEX, LEFT-HAND, M8 X 1.25 (DIN 934L), STAINLESS STEEL
36	2	111540	NUT, HEX, M10 X 1.5 (DIN 934), STAINLESS STEEL
37	8	C8006060	SCHNORR LOCK WASHER
38	8	C8005050	WASHER, 8.4 A2 DIN 125
39	8	C8004057	NUT, HEX, M8 A4
40	8	C6015213	SPACER, MOTOR 1.299 (FAN DISTANCE 2.008in)
41	2	C6015050	SPRING, MOTOR SHAFT SEAL
42	4	C6012011	DOORSTOPPER VA VST
43	1	C2017000	SAFETY RAIL, VST, X.20
44	1	C6012009	GUIDE STRIP, LOWER VST
45	1	19993	SWITCH, ROCKER, DPDT, ON/OFF 15A, 125V
46	1	C6005048	DIAPHRAGM GROMMET ø 60 mm (DG 48)
47	1	C6005427	DIAPHRAGM GROMMET ø 83 (DG60) FOR VAC. REG. VALVE
48	1	C2214157	ASSEMBLY, INTAKE PLATE IN 20.20
49	1	C2114292	AIR OUTLET CONECTING PIECE 20.20 GEN. 6.20/10.10/20.20 INJ.
50	1	C2115457	ASSEMBLY, TOP PANEL, GAS, INJECTOR, 20.20
51	1	300505	ASSEMBLY, COMPONENT PANEL, OGS 20.20
52	1	C21145392	ASSY, OUTER BASE, GAS, 20.20
53	2	C50180221	MOTOR W/STUD, ALL VOLTAGES, 3-PHASE, 4 POLE, 0.9KW, GAS COMBI
54	1	C2216796	ASSEMBLY, COVER, DEHUMIDIFYING GUTTER
55	1	C2215105	INNER HOUSING, GAS, INJ, 20.20, REI, KTM
56	1	C2214139	WELDMENT, AIR GUIDE, FAN SPACE, 20.20, GAS
57	1	C2010090	WELDMENT, HEAT EXCHANGER, LOWER, 20.20
58	1	C2010016	WELDMENT, HEAT EXCHANGER 10.20/12.20/20.20
59	1	C26142661	ASSEMBLY, CONTROLLER
60	2	C2614863	BURNER INSERT, HOT AIR, 110V, 10.20/12.20/20.20, NAT
61	1	C5115949	ASSEMBLY, EXTENSION, MOUNTING PLATE, GAS, 20.20

C2017012 Rectangle rail

COMPONENT PANEL ASSEMBLY, GAS

OGB 20.20 MODELS

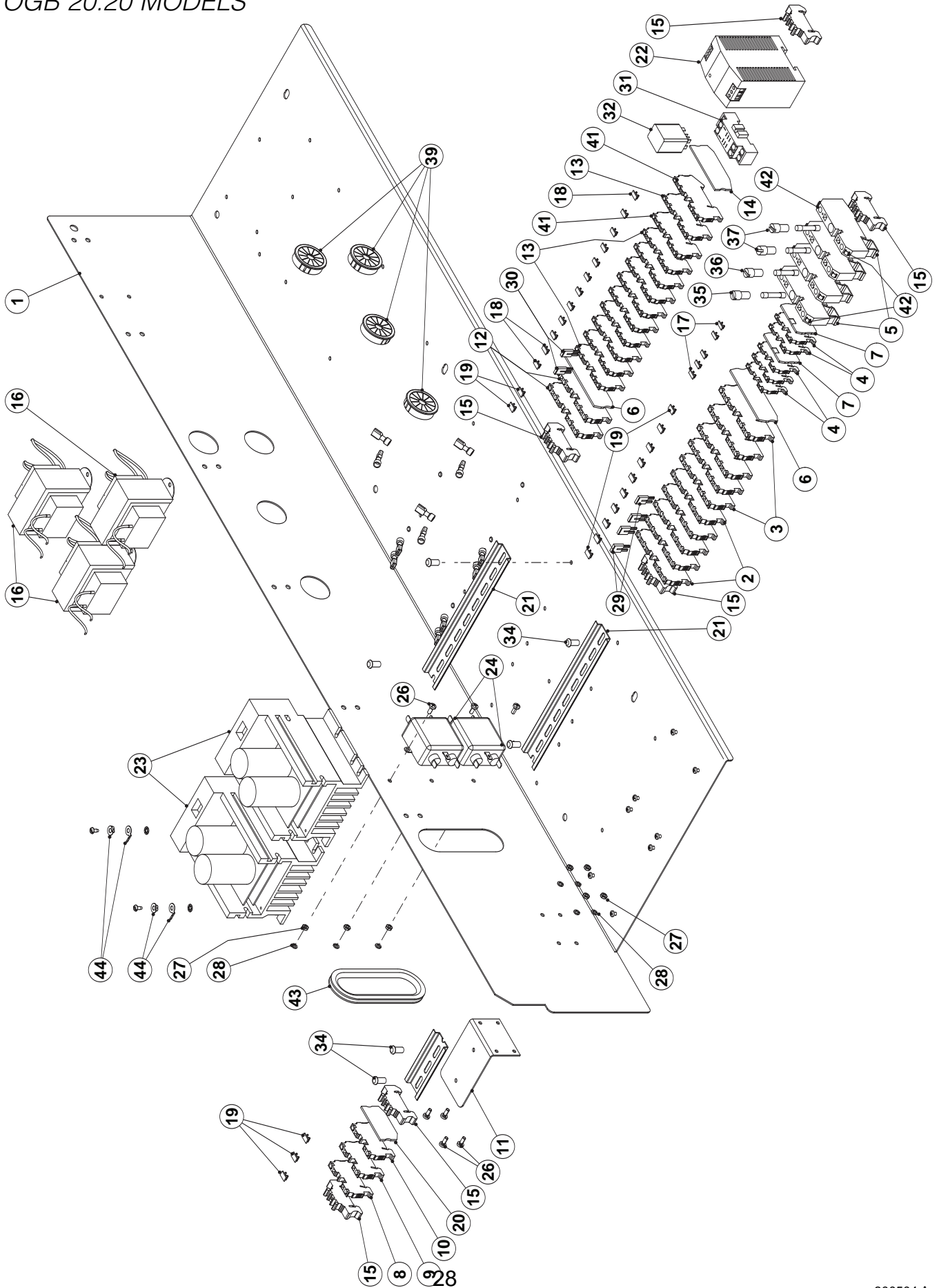

COMPONENT PANEL ASSEMBLY, GAS

OGB 20.20 MODELS

ITEM	QTY	PART NO.	DESCRIPTION
1	1	C5115405	PLATE, ELECTRICAL MOUNTING 20.20
2	5	C4014012	TERMINAL BLOCK, SPRING-LOADED, FOUR-WIRE, BLUE
3	5	C4014006	TERMINAL BLOCK, CONDUCTOR, SPRING-LOADED
4	5	C4014030	TERMINAL BLOCK, SPRING LOADED, 1.5MM2
5	4	C4014037	DINRAIL MOUNTED FUSEHOLDER (6.3X32)
6	2	C4014011	COVER, FOUR-WIRE
7	2	C4014031	COVER 2.5 MM2
8	1	C4014024	TERMINAL, FEED THROUGH, 4 MM2
9	1	C4014023	TERMINAL, FEED THROUGH,4MM2, BLUE
10	1	C4014016	TERMINAL, GROUNDED, SPRING LOADED, 2.5 MM2
11	1	C5116110	BRACKET, TERMINAL BLOCK, COMPONENT PANEL
12	2	C4014013	TERMINAL BLOCK, SPRING- LOADED, FOUR-WIRE
13	10	C4014010	TERMINAL, SPRING LOADED, FOUR WIRE, 2.5 MM2
14	1	C4014008	COVER FOUR-WIRE 2.5 MM2
15	6	C4014000	SNAP-ON END BRACKET
16	3	300419	TRANSFORMER, 24V
17	5	C4014033	LABEL BLANK, TERMINAL BLOCK, ZB4
18	12	C4014032	SERRATED COVER STRIP,PLAIN ZB5
19	15	C4014044	LABEL, BLANK, TERMINAL BLOCK, ZB6
20	1	C4014020	COVER 4 MM2
21	2	111601	DIN RAIL 8.375"
22	1	300350	POWER SUPPLY (12V)
23	2	300462	AC MOTOR DRIVE, 4 AMP
24	2	300472	FILTER, LINE, 20A
26	7	C8001024	SCREW, FILISTER HD, M4x10 DIN 7985
27	7	111605	M4 NUT
28	7	111606	M4 LOCK WASHER
29	4	C4014001	JUMPER, 2 PIN
30	2	C4014002	JUMPER 2-PIN
31	1	300473	RELAY SOCKET
32	1	03524	RELAY, DPDT, 120V, 50/60 Hz, AC
34	6	106123	SCREW, 10-32 X 1/2, TORX/ PAN HD, THRD FORMING, ZN
35	1	300416	FUSE MDA-2
36	1	300418	FUSE MDA-1
37	2	300471	FUSE, 20 AMP, MDA
38	1	111603	DIN RAIL 3.25"
39	4	111751	BUSHING, UNIVERSAL, 1.5DIA HOLE,HEYCO#2213,SNAP-IN UL
41	2	C4014009	TERMINAL BLOCK, SPRING LOADED, 1.5 MM2, BLUE
42	8	C4014039	LABEL BLANK, TERMINAL BLOCK, ZBF6
43	1	C700106611500	EDGE GUARD 11.500" LONG
44	4	20323	RING TO MALE TAB TERMINAL
49	8	106126	SCREW, 8-32 X 1/2, TORX/SLT.PAN HD
50	6	106127	SCREW, 6-32 X 1/2, TORX/PAN HD
51	6	300231	TERM., FULL INSUL, FEMALE, 0.250 TAB
52	6	20370	TERM.,FULL INSUL, MALE, 0.250 TAB

LIGHT ASSEMBLY ALL MODELS

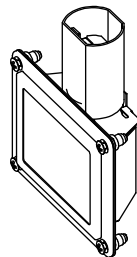
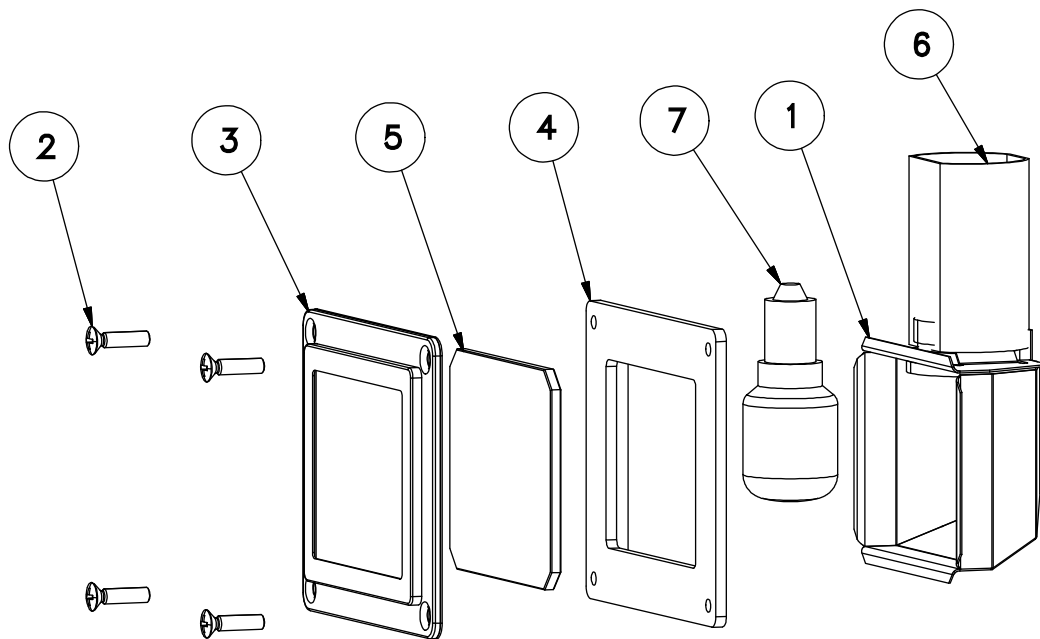

7	1	C5005045	BULB, LIGHT, 25W, 230V (ELECTRIC UNITS)
		C5005043	BULB, LIGHT, 25W, 120V (GAS UNITS)
6	1	C8019006	PROTECTION CAP, CAVITY LIGHT
5	1	C5015002	GLASS, CAVITY LIGHT
4	1	C6015020	GASKET, CAVITY LIGHT
3	1	C5015003	FRAME, CAVITY LIGHT
2	4	C8002025	ROUNDED COUNTERSUNK HEAD SCREW M4X16
1	1	C5015001	REFLECTOR HOUSING, CAVITY LIGHT
ITEM	QTY	PART NO.	DESCRIPTION

ASSEMBLY, CONTROL PANEL, WITH PICTO ALL MODELS

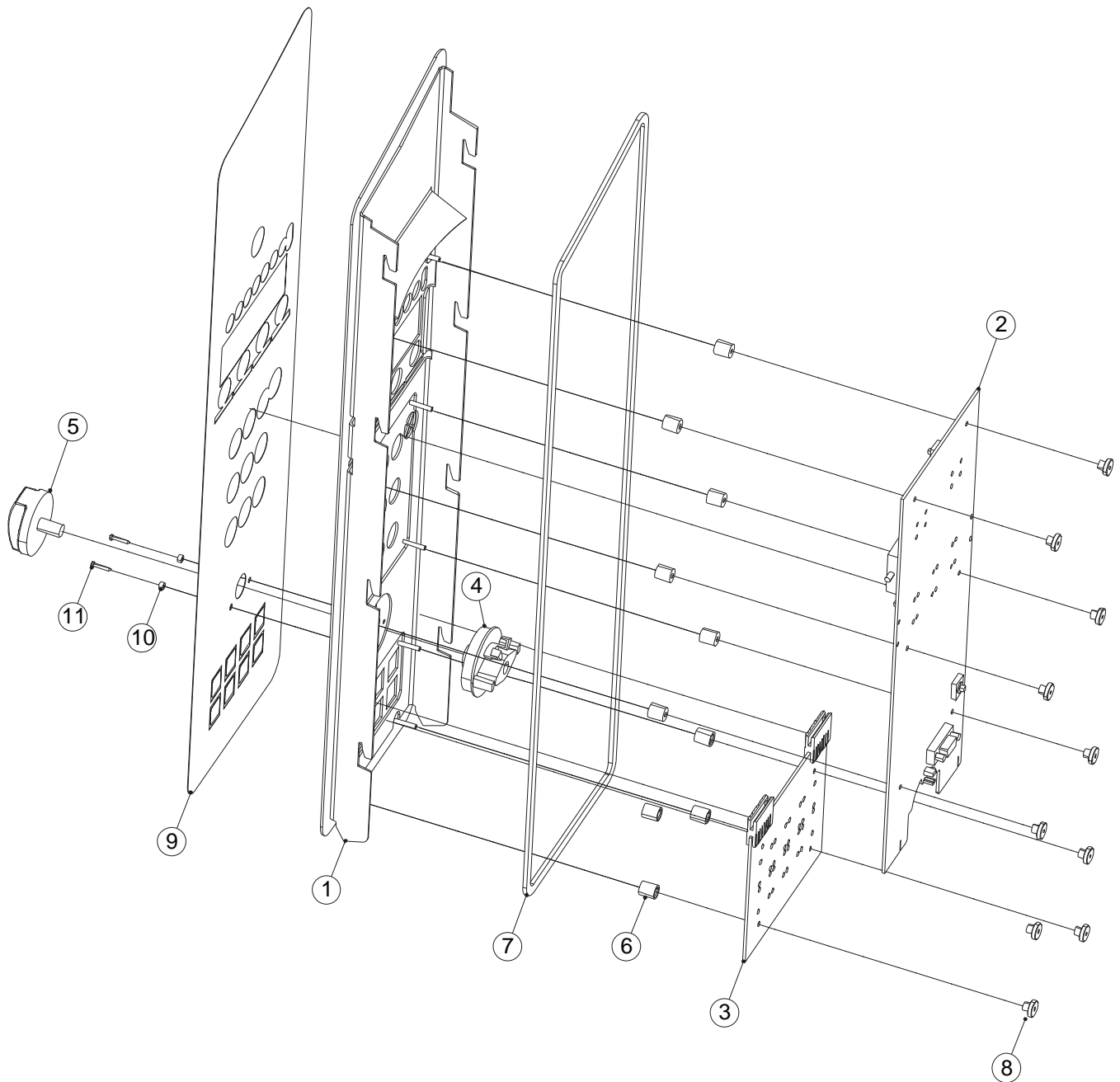

ITEM	QTY	PART NO.	DESCRIPTION
1	1	C2114297	WELDMENT CONTROL PANEL
2	1	FKC5019101-500	CONTROLLER, 5010 OPERATING MODULE
3	1	C5019105	CONTROLLER, 5010 PICTOMODULE PICTO
4	1	C5009313	LATCH ROCKER
5	1	C5009314	KNOB, SELECTOR, COMBI
6	10	C8009030	SPACER, CONTROL PANEL
7	1	C7011010	GASKET FRONT PLATE
8	10	C6005254	NUT KNURLED
9	1	111588	LABEL, CONTROL PANEL, STEAM GEN, WITH PICTO
	1	111590	LABEL, CONTROL PANEL, SPRITZER, WITH PICTO
10	2	C6005270	SPACER, CONTROL KNOB STOP
11	2	C8007013	SLOTTED PAN-HEAD TAPPING SCREW 2.2 X 13
12	1	300533	CABLE, CONNECTING, CONTROL (NOT SHOWN)

ASSEMBLY, OUTER BASE

OGB 20.20 MODELS

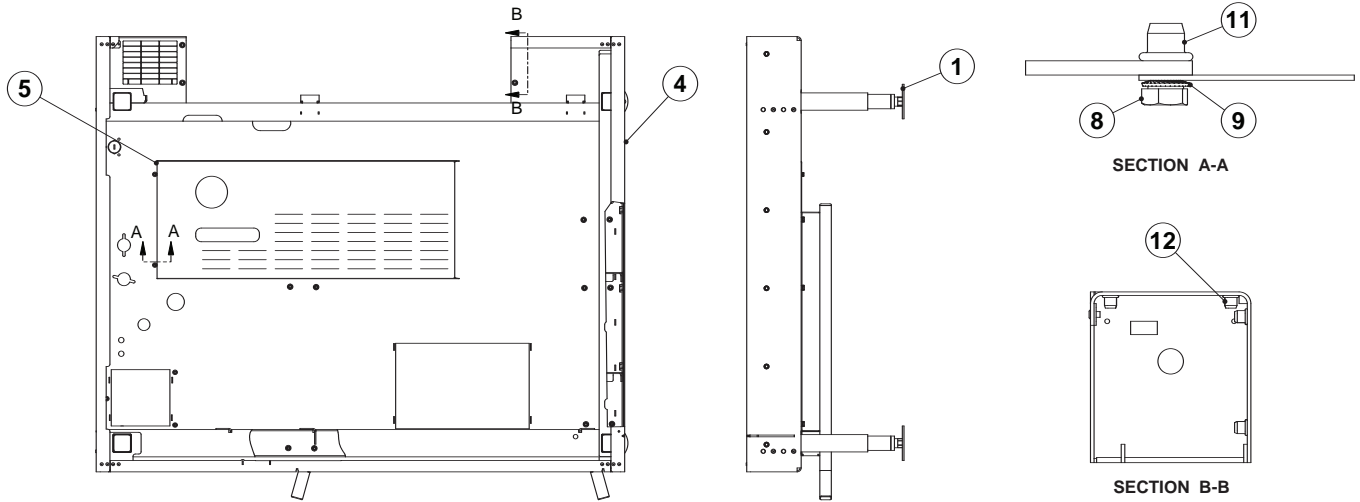

Pressure Switch C5009055
Agent Pump 300352

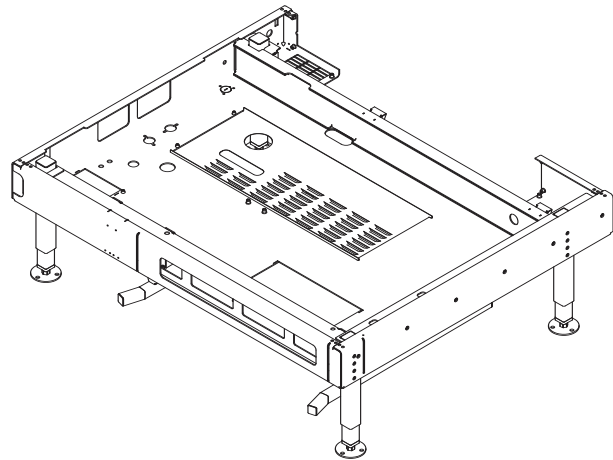

111950 foot ass'y for 1.50 SQ tubing

ITEM	QTY	PART NO.	DESCRIPTION
1	4	111970	Foot Ass'y for 1.25 SQ tubing
2	1	C2115476	WELDMENT, GUIDE RAIL, RIGHT, 12.20/20.20
3	1	C2115477	WELDMENT, GUIDE RAIL, LEFT, 12.20/20.20
4	1	C2115393	WELDMENT, BASE, GAS GENERATOR, 12.20/20.20
5	1	C2114627	COVER, BOTTOM, ACCESS, CONDENSER
6	10	C8006057	SCHNORR LOCK WASHER
7	10	C8003043	HEXAGON BOLT M6x16
8	2	C8003035	HEXAGON BOLT M5X10
9	2	C8006058	SCHNORR LOCK WASHER
10	2	111519	PLUG, 1" SQUARE, RIBBED, BLACK POLYETHYLENE, FITS ID 0.844" - 0.924"
11	7	C8008094	BLIND RIVET NUT M5 A2 HEXAGON
12	22	C8008089	BLIND RIVET NUT M6 A2 HEXAGON

CLEANING PUMP ASSEMBLY

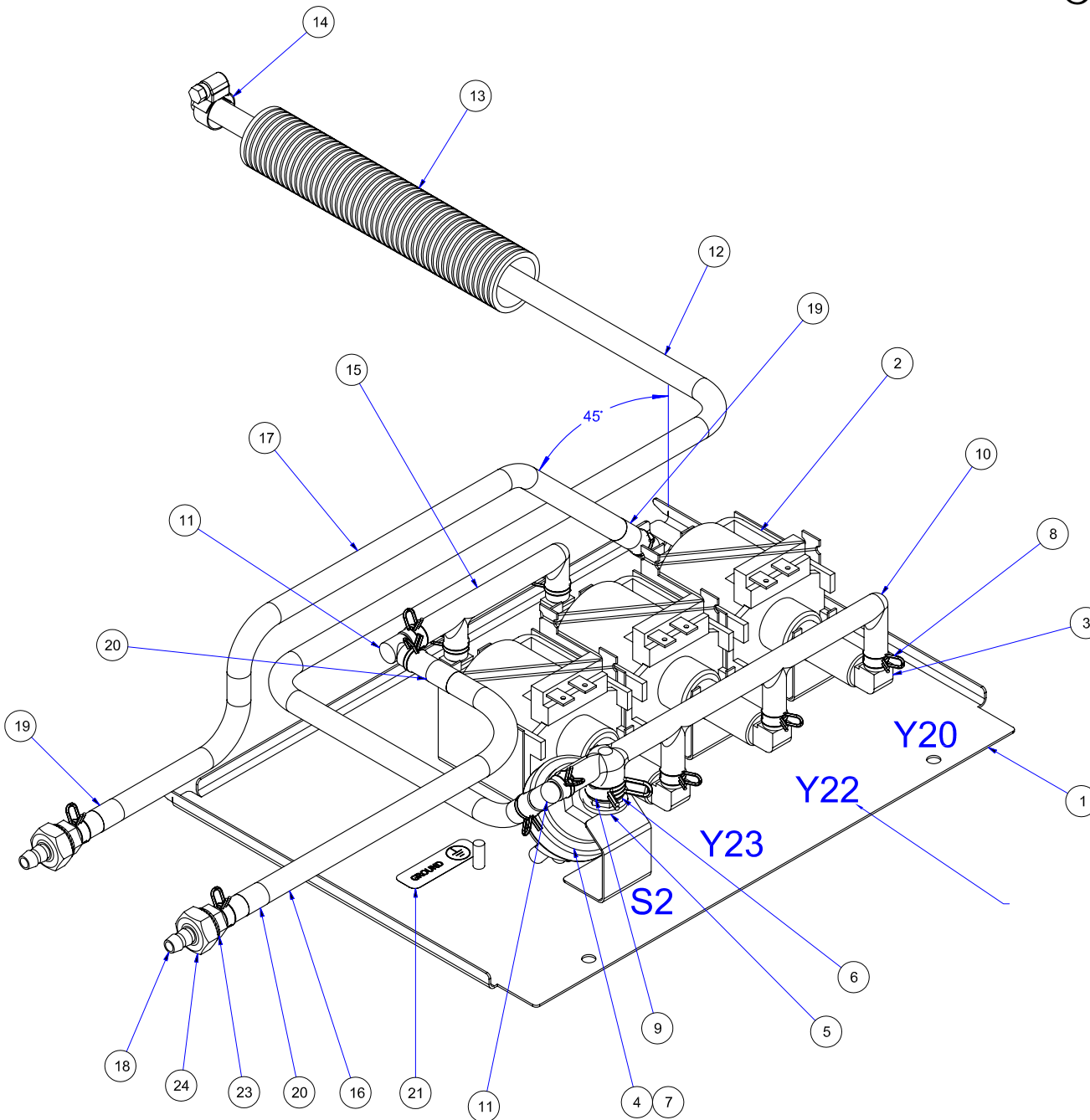

ITEM	QTY	PART NO.	DESCRIPTION
1	1	C2114823	WELDMENT, PUMP HOUSING, 110V P3
2	3	300352	PUMP, OSCILLATING PISTON, 110-120VAC, 60Hz P3
3	6	105787	FITTING, HOSE BARB, 90°, 1/4 H X 1/8 NPT(M)
4	1	C5009055	SWITCH, PRESSURE, AUTO CLEANING SYSTEM, P3
5	1	C6005016	GASKET, FLAT, 18.8mm OD X 10.3mm ID X 2mm THICK
6	1	C6015229	BUSHING, THREADED, PRESSURE SWITCH P3
7	A/R	111568	THREAD SEALANT, (LOCTITE 577)
8	12	C8009058	CLAMP, HOSE, SPRING, DOUBLE WIRE, 9.1 - 9.6 mm (0.358 - 0.378 in)
9	1	C8019010	CLAMP, HOSE, SPRING, DOUBLE WIRE, 14.1 - 14.8 mm (0.555 - 0.583 in)
10	1	C6014000	MANIFOLD, DISCHARGE, CLEANING PUMPS, EPDM
11	2	C6005414	FITTING, HOSE, 90 DEGREE ELBOW, 6mm BARB X 6mm BARB, PLASTIC (POM)
12	1	C701230265000	HOSE, EPDM, 6mm ID X 10mm OD, 65.000" LONG
13	1	C700204433500	HOSE, PROTECTION, 28mm OD X 23mm ID, CUT 33-1/2" LONG
14	1	106526	CLAMP, HOSE, WORM DRIVE, 3/8 TO 5/8x5/16W, SST
15	1	C6014001	MANIFOLD, SUCTION, CLEANING PUMPS, EPDM
16	1	C701230239500	HOSE, EPDM, 6mm ID X 10mm OD, 39.500" LONG
17	1	C701230245500	HOSE, EPDM, 6mm ID X 10mm OD, 45.500" LONG
18	2	C6015247	FITTING, BULKHEAD, HOSE, 6mm ID
19	2	C6019111	LABEL, BLUE, CONVOCARE, CLEANER HOSE
20	2	C6019109	LABEL, RED, CONVOCLEAN, CLEANER HOSE
21	1	14897	LABEL, GROUND
22	1	C5215890	HARNES, WIRE, CLEANING, 20.20
23	2	C8006063	WASHER, BELLEVILLE, M10, SERRATED BOTH SIDES, SST, 10.5mm ID X 16mm OD X 1mm THICK
24	2	111540	NUT, HEX, M10 X 1.5 (DIN 934), STAINLESS STEEL
25	1	14672	NUT, HEX, NYLOK, 10-32, 2P (FOR GROUND WIRE)
26	3	078180-1	O-RING

ASSEMBLY, WATER HOSE SYSTEM, CONDENSER

ALL MODELS

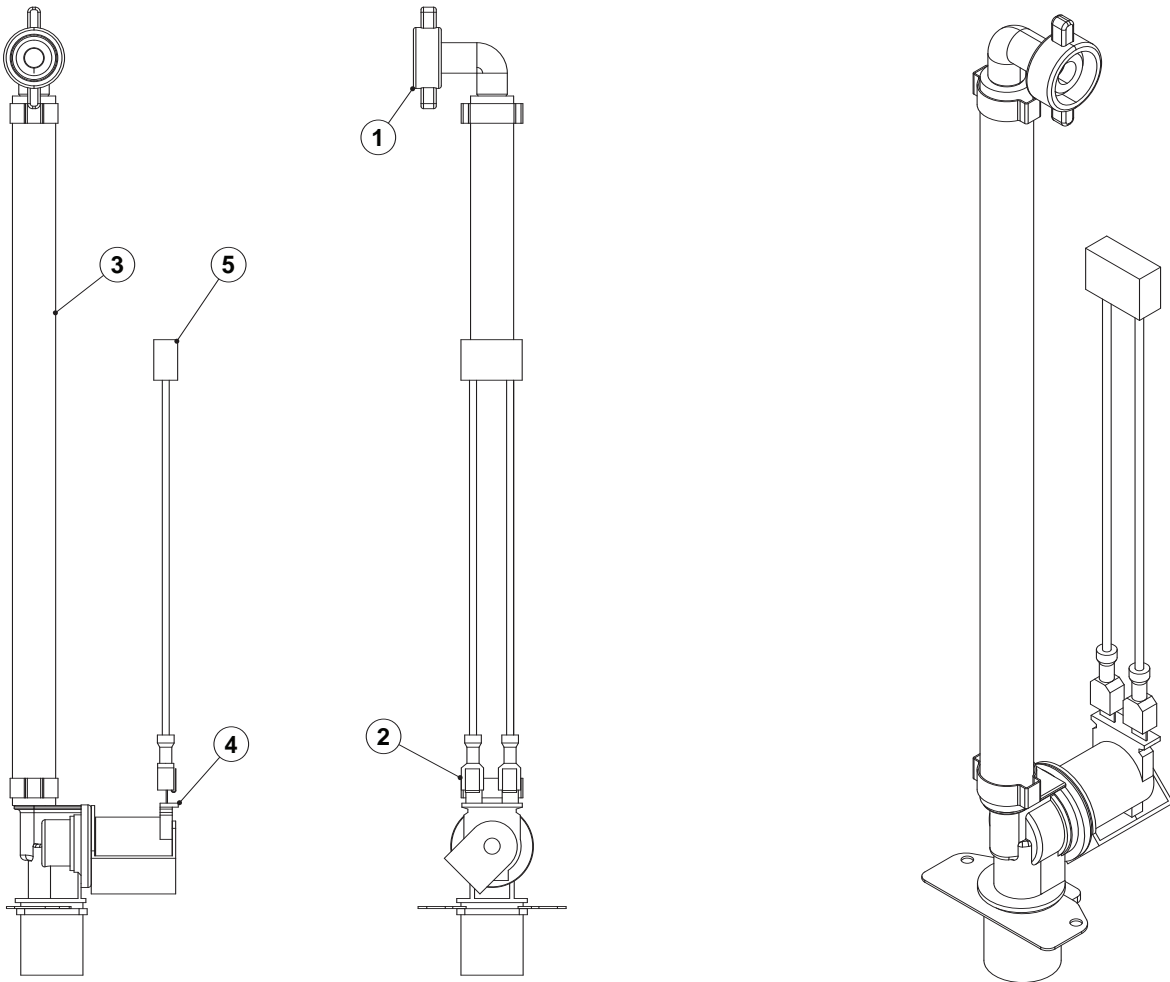

ITEM	QTY	PART NO.	DESCRIPTION
1	1	C6015215	ELBOW, HOSE CONNECTION, 3/8" WITH SEAL
2	2	111647	CLAMP, OETIKER, S/S, 19/32"
3	1	11149811000	HOSE, SILICONE, 3/8" ID X 11.000
4	1	300455	VALVE ASSEMBLY, 1 WAY, 120 VAC
5	1	300407	FILTER, ELECTRICAL
6	2	300509	TERMINAL, 18-22 AWG PIGGY BACK

ASSEMBLY, WATER VALVE

ALL 20.20 MODELS

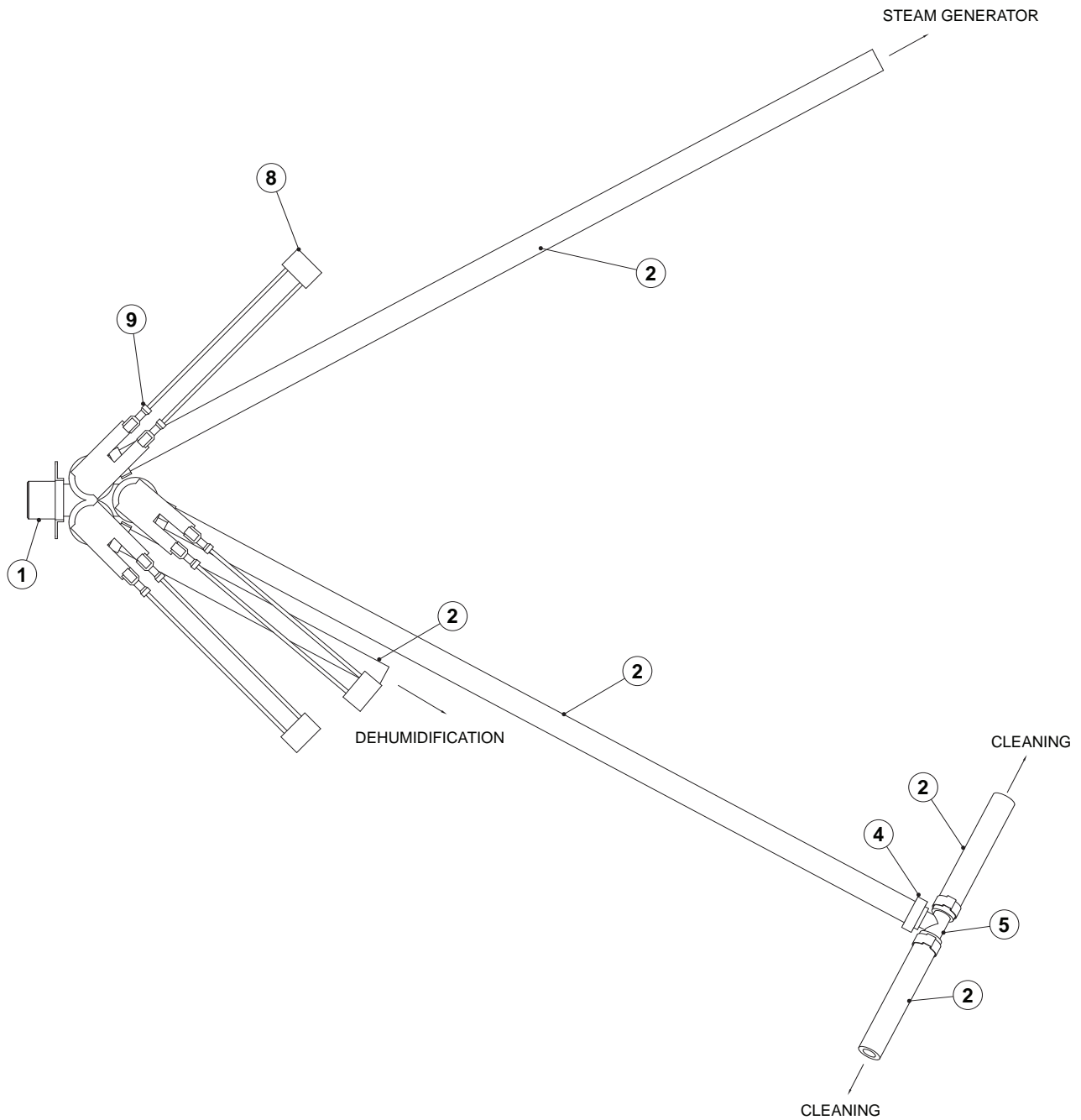

ITEM	QTY	PART NO.	DESCRIPTION
1	1	300453	VALVE ASSEMBLY, 3WAY 240VAC
1	1	300363	VALVE ASSEMBLY, 3WAY 120 VAC
2	5	111498	HOSE, SILICONE, 3/8" ID (SPECIFY LENGTH)
4	6	111647	CLAMP, OETIKER, S/S, 19/32"
5	1	111646	TEE, BRASS, 3/8" BRASS
8	3	300407	FILTER, ELECTRICAL
9	6	300509	TERMINAL, 18-22 AWG PIGGY BACK

ASSEMBLY, WATER VALVE

OGB 20.20 MODELS

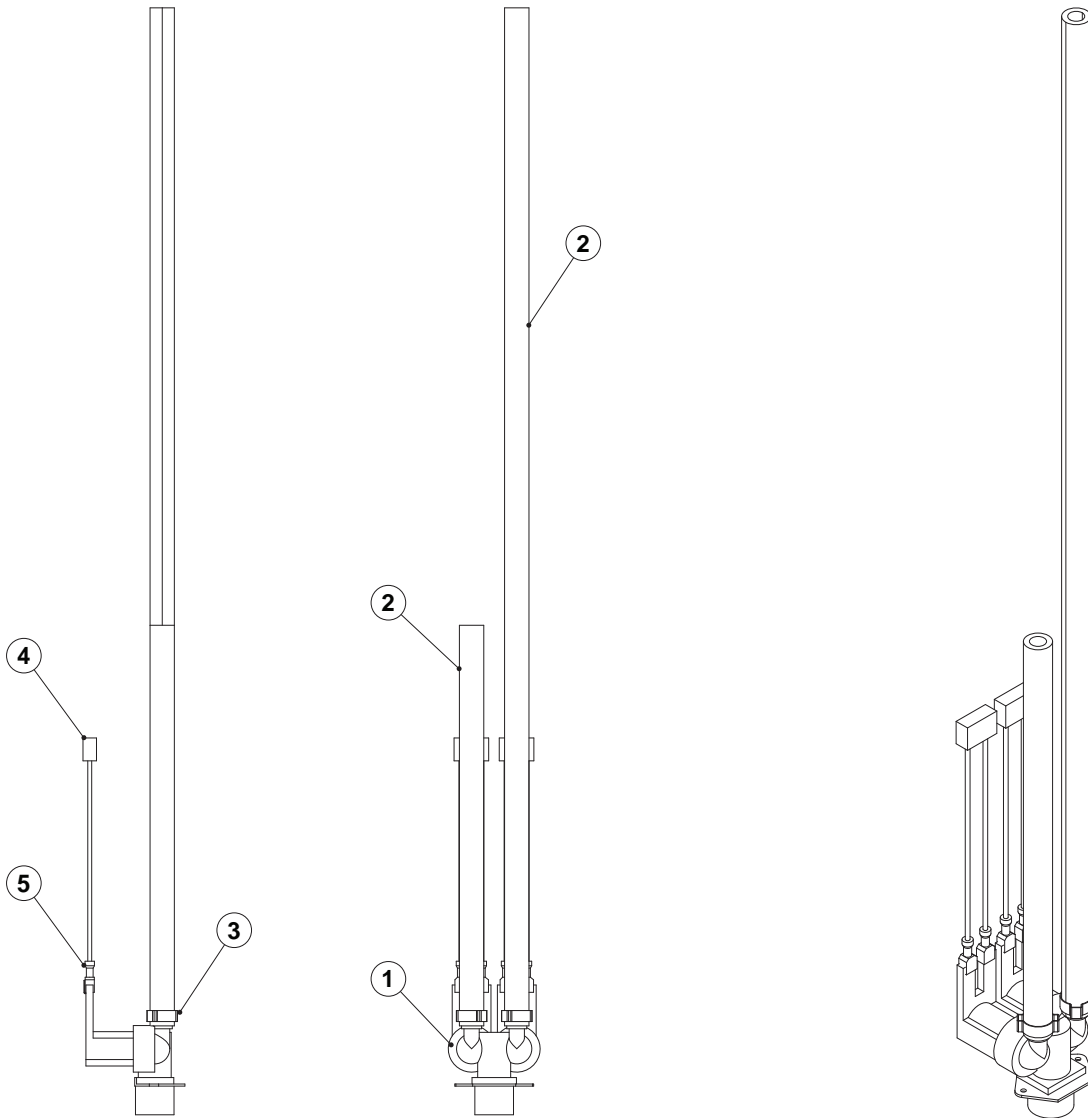

ITEM	QTY	PART NO.	DESCRIPTION
1	1	300456	VALVE ASSY. 2 WAY 120VAC
2	2	111498	HOSE, SILICONE, 3/8" ID (SPECIFY LENGTH)
3	2	111647	CLAMP, OETIKER, S/S, 19/32"
4	2	300407	FILTER, ELECTRICAL
5	4	300509	TERMINAL, 18-22 AWG PIGGY BACK

WATER VALVE ASSEMBLY OES & OGS MODELS AFTER JANUARY 2010

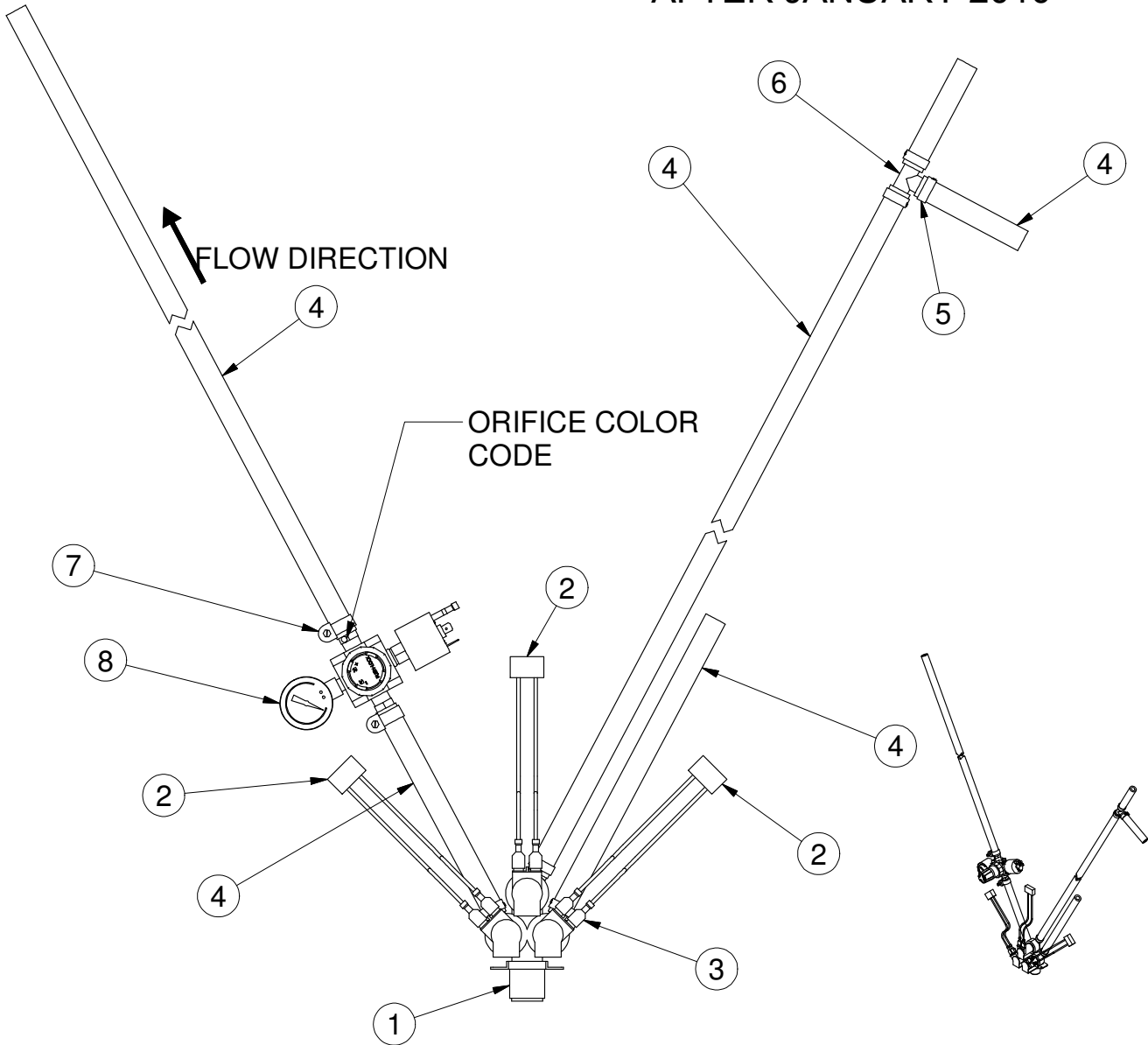

ITEM	QTY	PART NO.	DESCRIPTION
1	1	300453 300363	VALVE, SOLENOID, 3 WAY, 240VAC VALVE, SOLENOID, 3 WAY, 120VAC
2	3	300407	FILTER, ELECTRICAL, RC NETWORK, 125 VAC, 200 VDC
3	6	300509	TERMINAL, SLIPON, INSUL., 18-22 AWG, PIGGYBACK
4	7	111498	HOSE, SILICONE, 0.375" ID X 0.655" OD
5	6	C6016070	CLAMP, HOSE, 0.630" - 0.756", SST, OETIKER
6	1	111646	TEE, HOSE BARB, BRASS, 3/8"H X 3/8"H X 3/8"H
7	2	C6006086	HOSE CLAMP, 1/2" 12-20 MM, 15 MM ADJUSTED
8	1	SEE DRAWING	REGULATOR ASSEMBLY, W / ORIFICE, COMBI

REGULATOR ASSEMBLY

ASSEMBLY PART NO.	ORIFICE FTG. PN.	ORIFICE SIZE	COLOR CODE	
FK1132281	1132301	0.5mm	RED	3.10
FK1132282	1132302	0.6mm	BLUE	6.20/10.10/10.20
FK1132283	1132303	0.7mm	YELLOW	12.20
FK1132284	1132304	1.0mm	GREEN	20.20

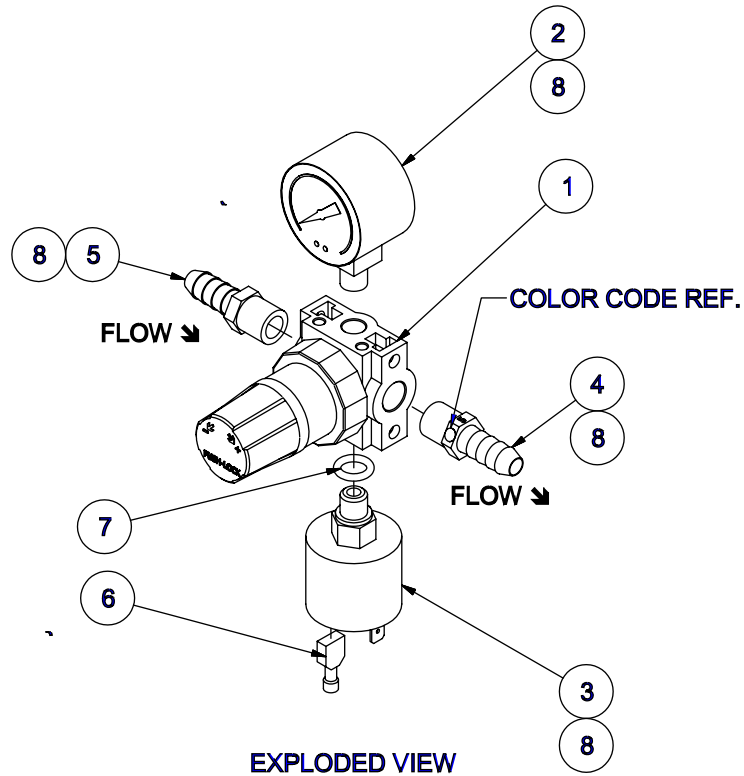

8	A/R	111651	SEALANT, LOCTITE, WHITE, HIGH TEMP, DRI-SEAL 513
7	1	113236	O-RING, 3/8"ID X 9/16"OD X 3/32"THK, BUNA-N
6	1	20356	SLIP-ON FULL INSULATED, FEMALE, 0.032 X 0,250
5	1	105277	FTG, HOSE BARB, 3/8 H X 1/4 NPT, BR
4	1	SEE CHART	FTG, HOSE BARB, 3/8 H X 1/4 NPT, BR; W/ORIFICE
3	1	C5009063	SWITCH, PRESSURE, INJECTOR SYSTEM
2	1	C6006140	GAUGE, PRESSURE, 0-60 PSI (4 BAR) 1/8" BPP BOTTOM CONNECTION
1	1	113229	REGULATOR, 0-60PSIG, 1/4"NPT
ITEM	QTY	PART NO.	DESCRIPTION

BURNER INSERT, HL, PRE-MOUNTED

ALL GAS MODELS

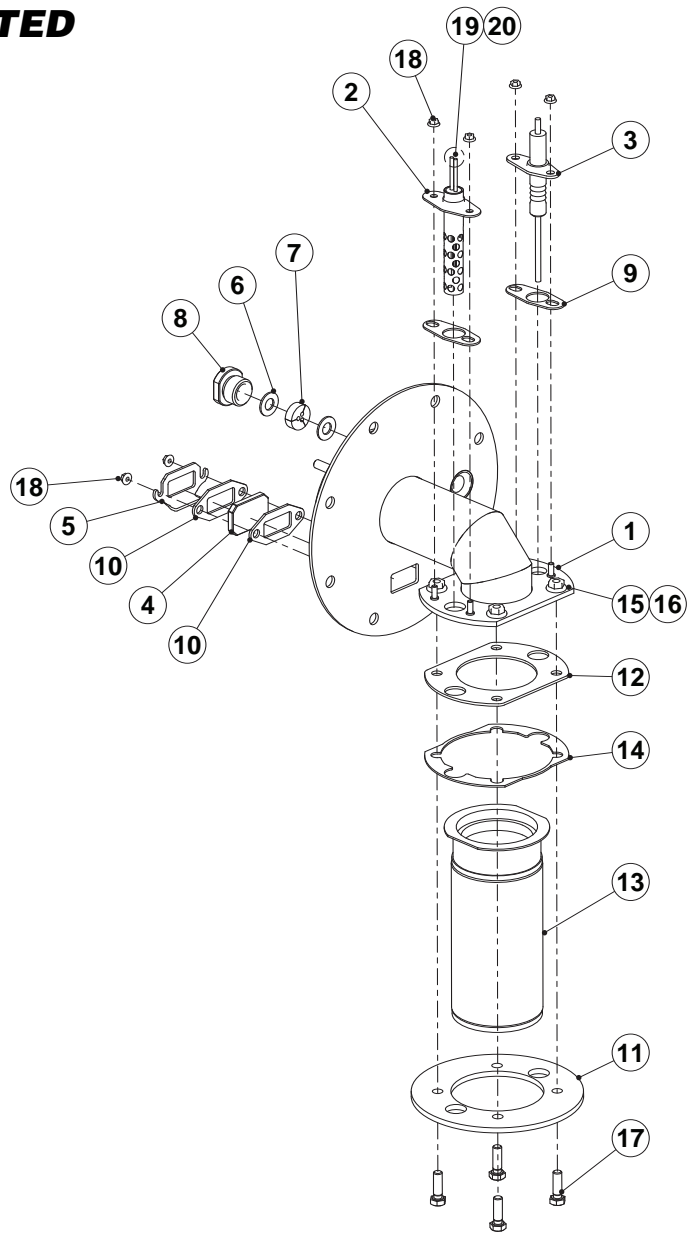
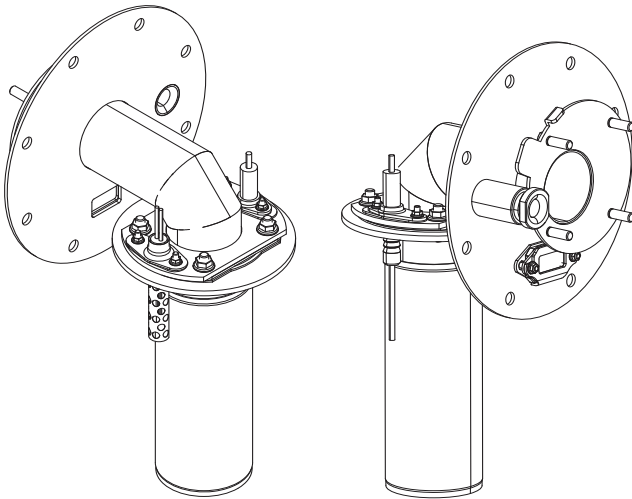

ITEM	QTY	PART NO.	DESCRIPTION
1	1	C2010050	BURNER INSERT HL, 6.10/6.20, WELDMENT
	1	C2010052	BURNER INSERT, HL, 10.10/20.10, WELDMENT
2	1	C4018001	AUTO-IGNITION ELECTRODE
3	1	C4018000	MONITORING ELECTRODE
4	1	C5015004	INSPECTION GLASS, BURNER
5	1	C2614845	COVER, INSPECTION GLASS, BURNER
6	2	C6015240	WASHER, CABLE BUSHING, BURNER INSERT
7	1	C6015041	SEAL, CABLE BUSHING BURNER INSERT
8	1	C6015238	SCREW CONNECTION, CABLE BUSHING, BURNER INSERT
9	2	C2614849	LINING PLATE, ELECTRODE, GAS
11	1	C2614842	CLAMPING FLANGE, BURNER, HL, Ø 50
10	2	C6015039	SEAL, INSPECTION GLASS, BURNER
12	1	C6015032	SEAL, BURNER Ø 50 MM
13	1	C2010014	BURNER, Ø 50 x150, 20 KW
14	1	C2615367	FLANGE, BURNER
15	A/R	C7014000	COPPER PASTE
16	4	C8017010	FLANGE NUT
17	4	C8003095	HEXAGON BOLT, M5x16, HUD 20.20
18	6	C8017008	NUT, LOCKING, SERRATED
19	1	300484	TERM, PUSHON, .110, 22-16AWG SEMI INSUL. (NOT SHOWN)
20	1	20351	TERM, SLIPON FULL INSUL. .032X.25 TAB 22-18AWG (NOT SHOWN)

COMPLETE BURNER ASSEMBLY NAT

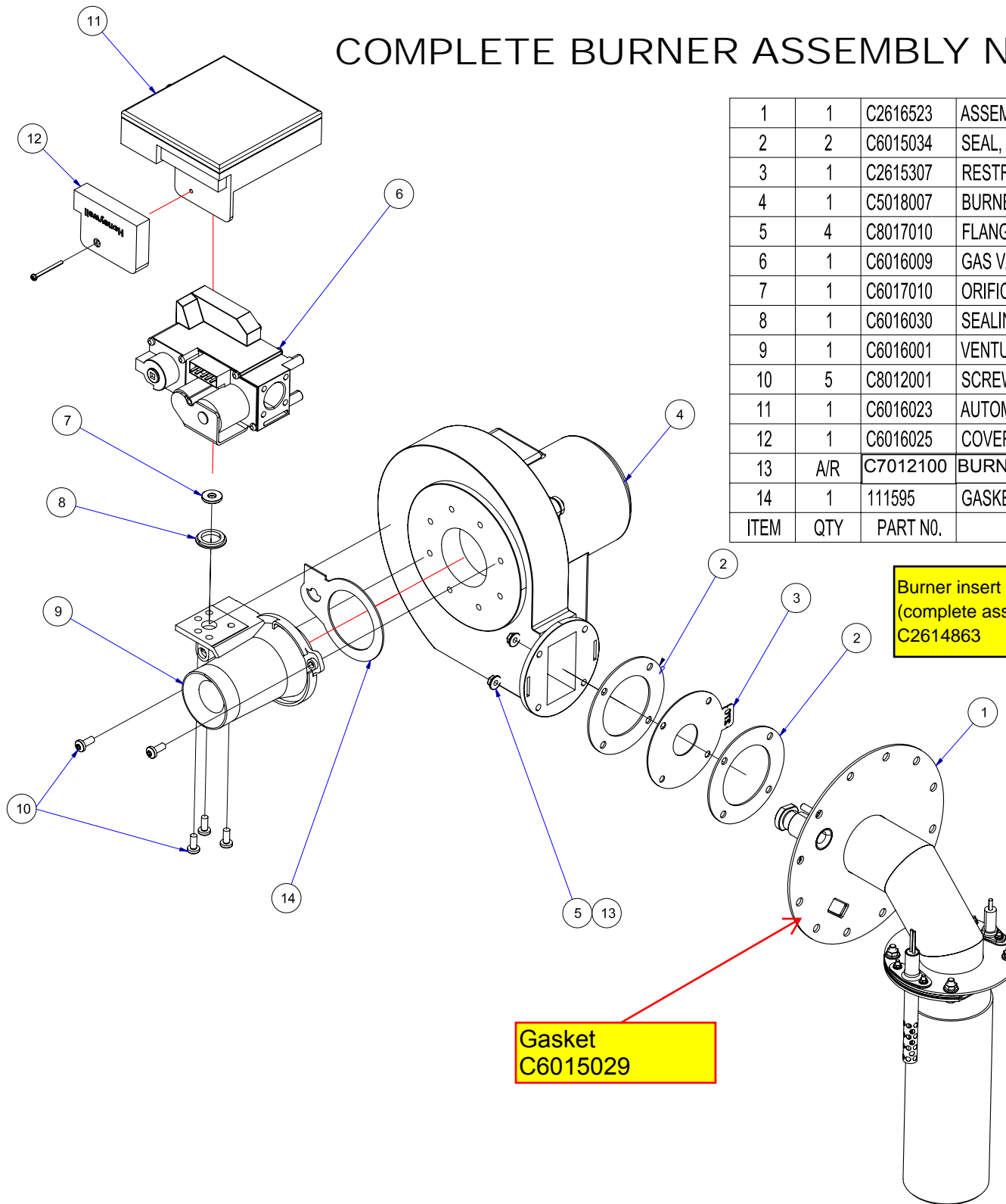

1	1	C2616523	ASSEMBLY, BURNER INSERT, HOT AIR, 10.20/12.20/20.20
2	2	C6015034	SEAL, FAN RG128/148 P3
3	1	C2615307	RESTRICTION FLANGE RG148 Ø270
4	1	C5018007	BURNER BLOWER RG148 110V
5	4	C8017010	FLANGE NUT, M5, A4, P3
6	1	C6016009	GAS VALVE, HONEYWELL, 110V, P3
7	1	C6017010	ORIFICE, Ø6.20
8	1	C6016030	SEALING RING, GAS SCREEN, P3
9	1	C6016001	VENTURI 56 KW P3
10	5	C8012001	SCREW, M5x12, FILLISTER HD, TORX
11	1	C6016023	AUTOMATIC FIRING DEVICE, 110V, AUTO-IGNITION, P3
12	1	C6016025	COVER, AUTOMATIC FIRING DEVICE
13	A/R	C7012100	BURNER INTAKE HOSE (NOT SHOWN)
14	1	111595	GASKET, CORK, BURNER VENTURI, COMBI
ITEM	QTY	PART NO.	DESCRIPTION

Burner insert 20.20 Natural Gas
(complete assembly Ryan)
C2614863

Gasket
C6015029

COMPLETE BURNER ASSEMBLY LP

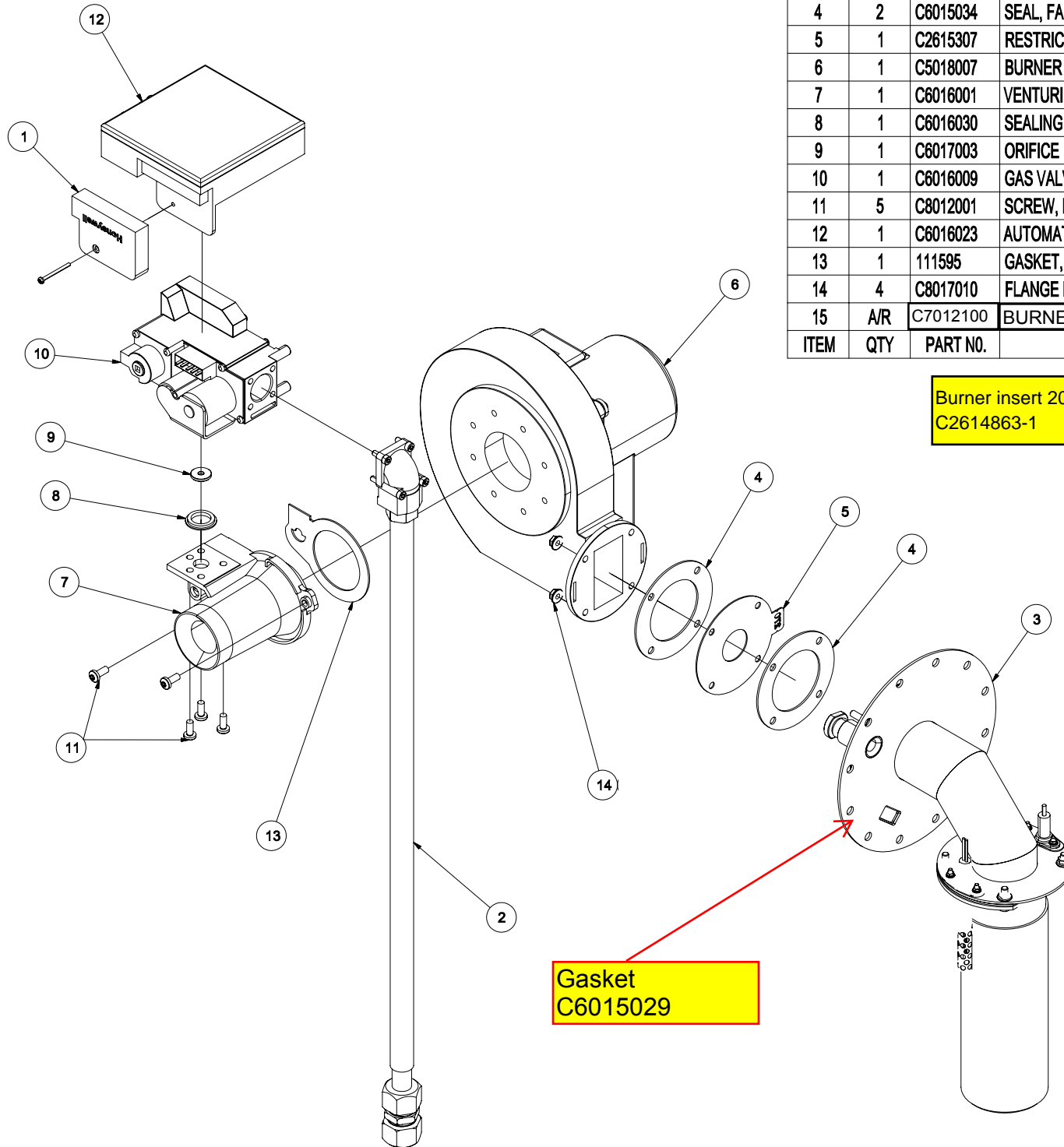

1	1	C6016025	COVER, AUTOMATIC FIRING DEVICE
2	1	C2616516	GAS HOSE, 580 LG, PREASSEMBLED
3	1	C2616523	ASSEMBLY, BURNER INSERT, HOT AIR, 10.20/12.20/20.20
4	2	C6015034	SEAL, FAN RG128/148 P3
5	1	C2615307	RESTRICTION FLANGE RG148 Ø270
6	1	C5018007	BURNER BLOWER RG148 110V
7	1	C6016001	VENTURI 56 KW P3
8	1	C6016030	SEALING RING, GAS SCREEN, P3
9	1	C6017003	ORIFICE Ø440 P3
10	1	C6016009	GAS VALVE, HONEYWELL, 110V, P3
11	5	C8012001	SCREW, M5x12, FILLISTER HD, TORX
12	1	C6016023	AUTOMATIC FIRING DEVICE, 110V, AUTO-IGNITION, P3
13	1	111595	GASKET, CORK, BURNER VENTURI, COMBI
14	4	C8017010	FLANGE NUT, M5, A4, P3
15	A/R	C7012100	BURNER INTAKE HOSE (NOT SHOWN)
ITEM	QTY	PART NO.	DESCRIPTION

Burner insert 20.20 L.P. (complete assembly Ryan)
C2614863-1

Gasket
C6015029

ASSEMBLY, BURNER INSERT, AIR, LP & NAT GAS

ALL GAS MODELS

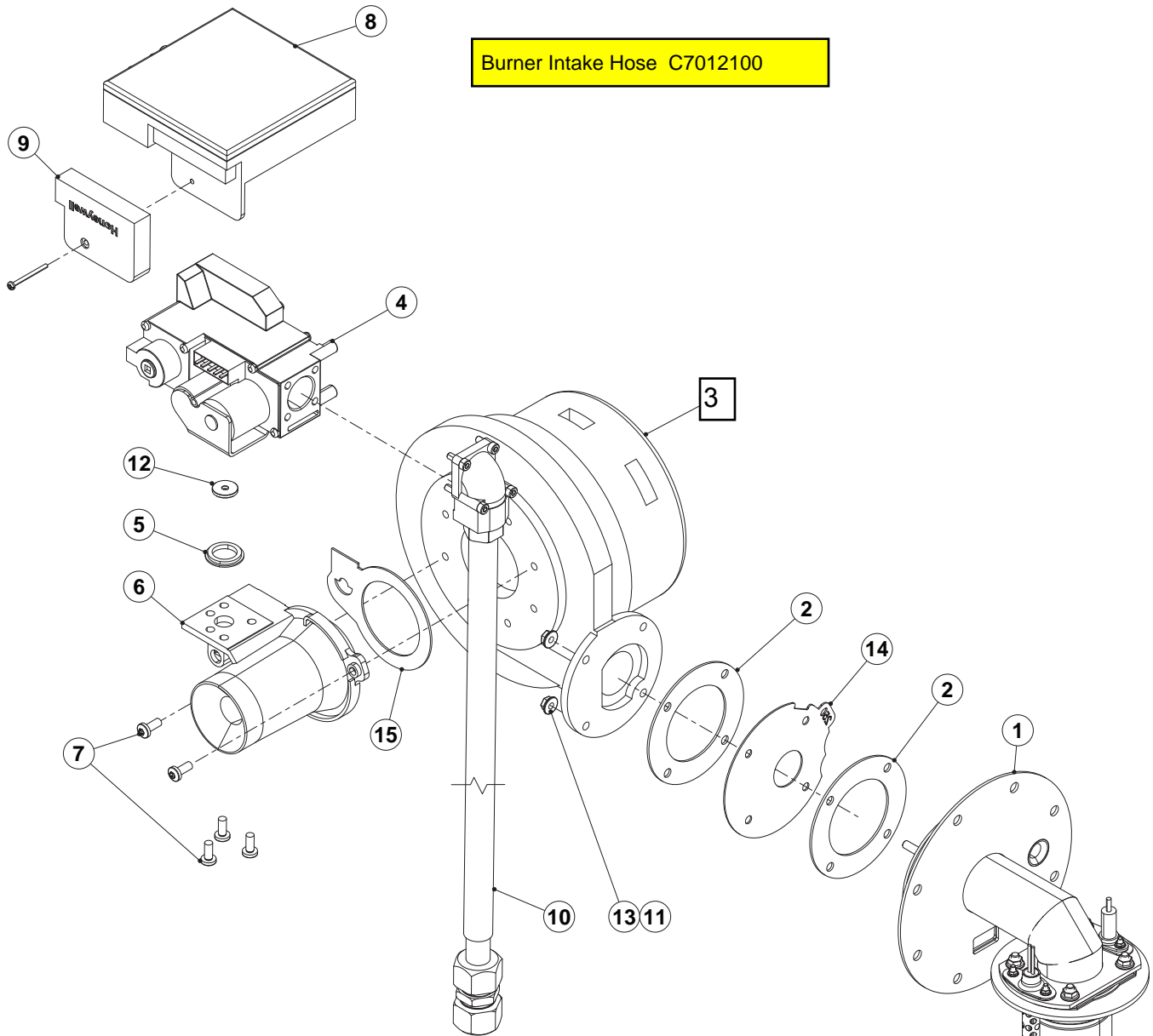

ITEM	QTY	PART NO.	DESCRIPTION
1	1	C2616521	BURNER INSERT, HL, PRE-MOUNTED, 6.10/6.20
	1	C2616522	BURNER INSERT, HL, PRE-ASSEMBLED, 10.10/20.10
2	2	C6015034	SEAL, FAN RG128/148
3	1	C5018007	BURNER BLOWER, RG128, 110V
4	1	C6016009	GAS VALVE, HONEYWELL, 110V
5	1	C6016030	SEALING RING, GAS SCREEN
6	1	C6016000	VENTURI 40 KW
7	5	C8012001	SCREW, M5x12, FILLISTER HD, TORX
8	1	C6016023	AUTOMATIC FIRING DEVICE, 110V, AUTO-IGNITION
9	1	C6016025	COVER, AUTOMATIC FIRING DEVICE
10	1	C2616516	GAS HOSE, 580mm LG, PREASSEMBLED, 6.20
	1	C2616517	GAS HOSE, 780mm LG, PREASSEMBLED, 10.10/20.10
11	A/R	C7014000	COPPER PASTE
12	1	C6017001	ORIFICE \varnothing 400, LP GAS
	1	C6017009	ORIFICE, \varnothing 0565 NAT GAS
13	4	C8017010	FLANGE NUT
14	1	C2615355	FLANGE, RESTRICTION \varnothing 250
15	1	111595	GASKET, CORK, BURNER VENTURI, COMBI

Complete Assembly LP: C2314903-1

Burner Intake Hose C7012100

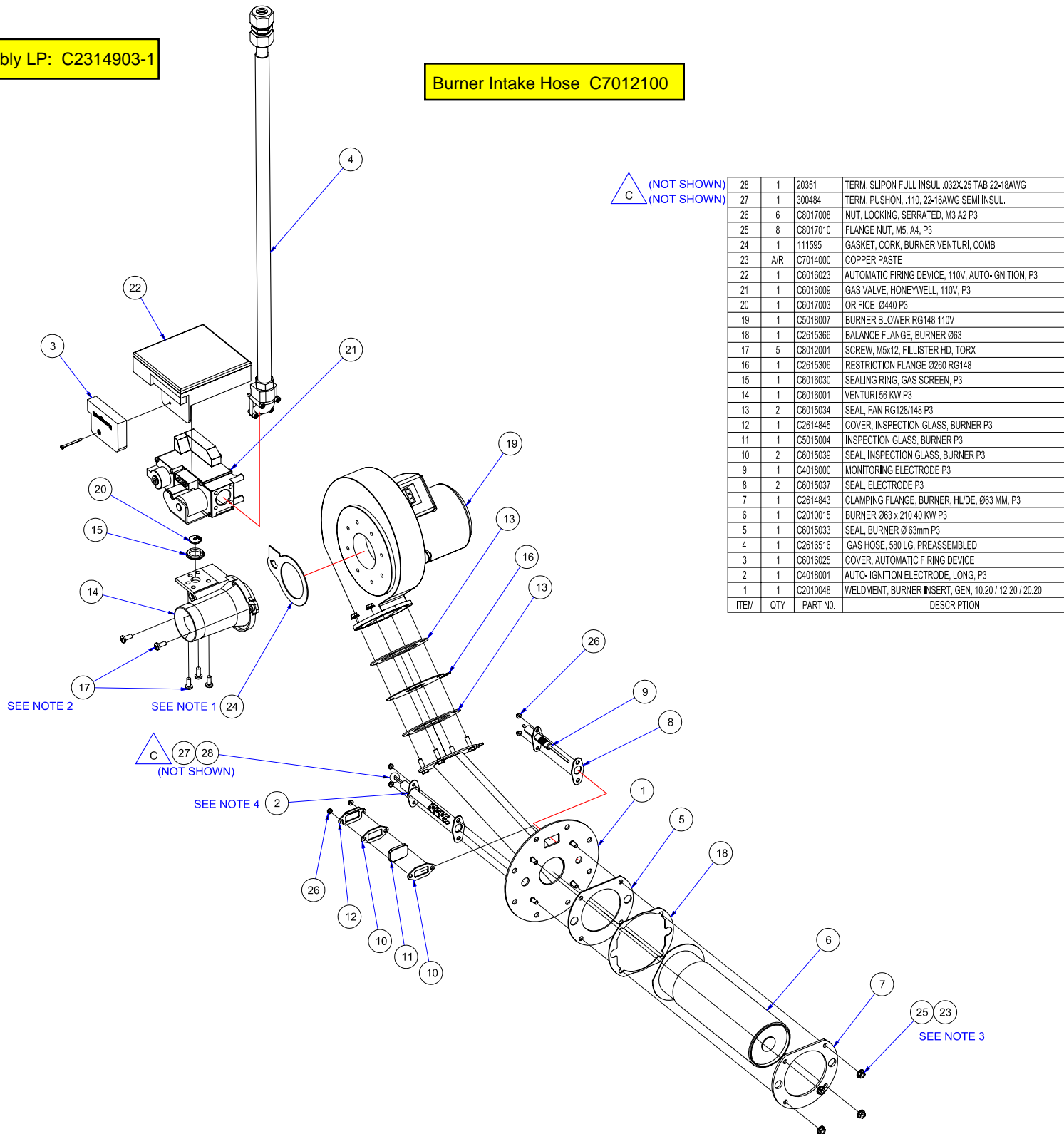

ITEM	QTY	PART NO.	DESCRIPTION
28	1	20351	TERM. SLIPON FULL INSUL .032X.25 TAB 22-18AWG
27	1	300484	TERM. PUSHON, .110, 22-16AWG SEMI INSUL.
26	6	C8017008	NUT, LOCKING, SERRATED, M3 A2 P3
25	8	C8017010	FLANGE NUT, M5, A4, P3
24	1	111595	GASKET, CORK, BURNER VENTURI, COMBI
23	A/R	C7014000	COPPER PASTE
22	1	C6016023	AUTOMATIC FIRING DEVICE, 110V, AUTO-IGNITION, P3
21	1	C6016009	GAS VALVE, HONEYWELL, 110V, P3
20	1	C6017003	ORIFICE Ø440 P3
19	1	C5018007	BURNER BLOWER RG148 110V
18	1	C2615386	BALANCE FLANGE, BURNER Ø63
17	5	C8012001	SCREW, M5x12, FILLISTER HD, TORX
16	1	C2615306	RESTRICTION FLANGE Ø280 RG148
15	1	C6016030	SEALING RING, GAS SCREEN, P3
14	1	C6016001	VENTURI 56 KW P3
13	2	C6015034	SEAL, FAN RG128/148 P3
12	1	C2614845	COVER, INSPECTION GLASS, BURNER P3
11	1	C5015004	INSPECTION GLASS, BURNER P3
10	2	C6015039	SEAL, INSPECTION GLASS, BURNER P3
9	1	C4018000	MONITORING ELECTRODE P3
8	2	C6015037	SEAL, ELECTRODE P3
7	1	C2614843	CLAMPING FLANGE, BURNER, HL/DE, Ø63 MM, P3
6	1	C2010015	BURNER Ø63 x 210.40 KW P3
5	1	C6015033	SEAL, BURNER Ø 63mm P3
4	1	C2616516	GAS HOSE, 580 LG, PREASSEMBLED
3	1	C6016025	COVER, AUTOMATIC FIRING DEVICE
2	1	C4018001	AUTO-IGNITION ELECTRODE, LONG, P3
1	1	C2010048	WELDMENT, BURNER INSERT, GEN, 10.20 / 12.20 / 20.20

Complete Assembly: C2314903

Burner Intake Hose C701210023675

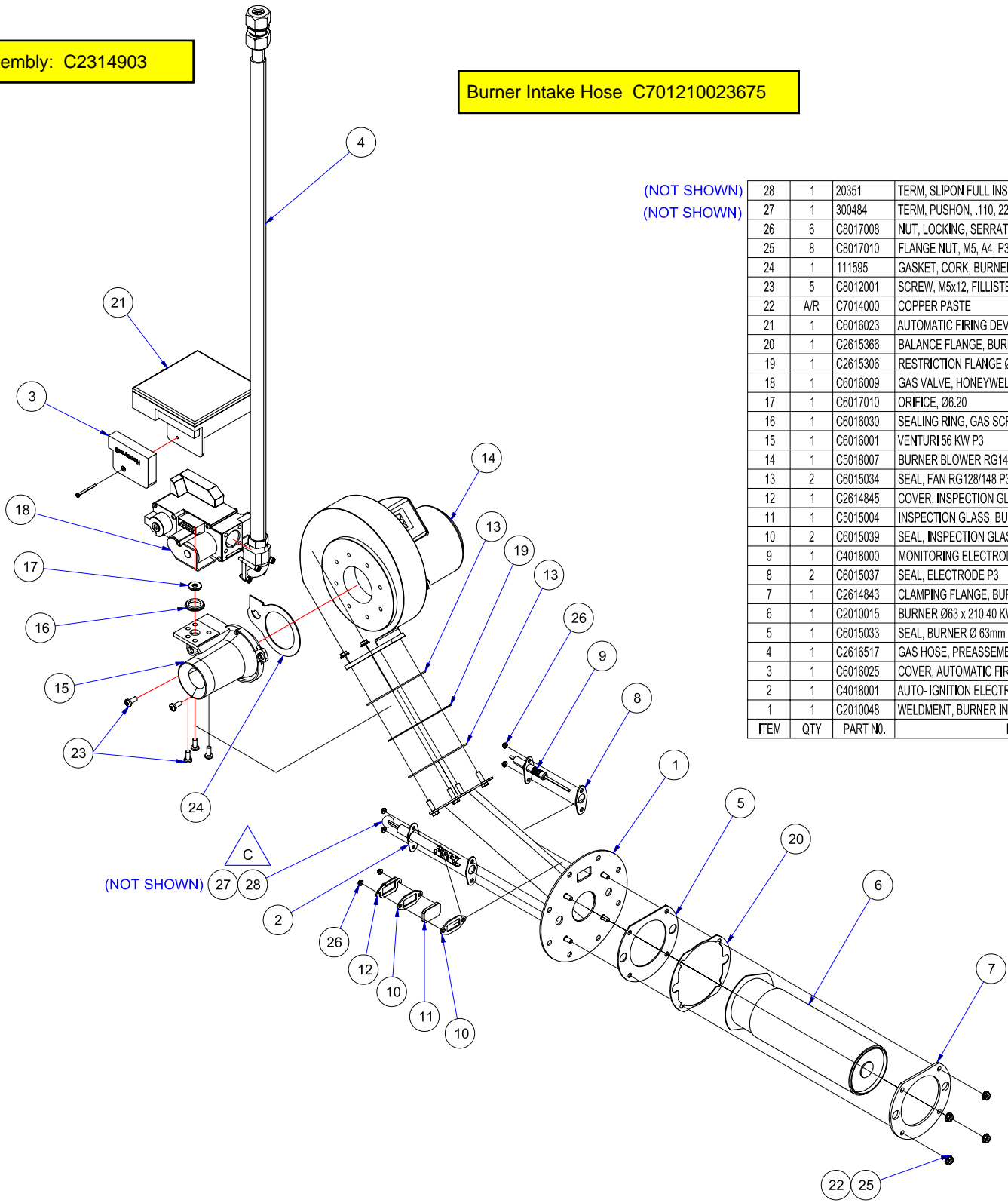

(NOT SHOWN)
(NOT SHOWN)

ITEM	QTY	PART NO.	DESCRIPTION
28	1	20351	TERM, SLIPON FULL INSUL .032X.25 TAB 22-18AWG
27	1	300484	TERM, PUSHON, .110, 22-16AWG SEMI INSUL.
26	6	C8017008	NUT, LOCKING, SERRATED, M3 A2 P3
25	8	C8017010	FLANGE NUT, M5, A4, P3
24	1	111595	GASKET, CORK, BURNER VENTURI, COMBI
23	5	C8012001	SCREW, M5x12, FILLISTER HD, TORX
22	A/R	C7014000	COPPER PASTE
21	1	C6016023	AUTOMATIC FIRING DEVICE, 110V, AUTO-IGNITION, P3
20	1	C2615366	BALANCE FLANGE, BURNER Ø63
19	1	C2615306	RESTRICTION FLANGE Ø260 RG148
18	1	C6016009	GAS VALVE, HONEYWELL, 110V, P3
17	1	C6017010	ORIFICE, Ø6.20
16	1	C6016030	SEALING RING, GAS SCREEN, P3
15	1	C6016001	VENTURI 56 KW P3
14	1	C5018007	BURNER BLOWER RG148 110V
13	2	C6015034	SEAL, FAN RG128/148 P3
12	1	C2614845	COVER, INSPECTION GLASS, BURNER P3
11	1	C5015004	INSPECTION GLASS, BURNER P3
10	2	C6015039	SEAL, INSPECTION GLASS, BURNER P3
9	1	C4018000	MONITORING ELECTRODE P3
8	2	C6015037	SEAL, ELECTRODE P3
7	1	C2614843	CLAMPING FLANGE, BURNER, HL/DE, Ø63 MM, P3
6	1	C2010015	BURNER Ø63 x 210 40 KW P3
5	1	C6015033	SEAL, BURNER Ø 63mm P3
4	1	C2616517	GAS HOSE, PREASSEMBLED, 780mm LONG
3	1	C6016025	COVER, AUTOMATIC FIRING DEVICE
2	1	C4018001	AUTO-IGNITION ELECTRODE, LONG, P3
1	1	C2010048	WELDMENT, BURNER INSERT, GEN, 10.20 / 12.20 / 20.20
ITEM	QTY	PART NO.	DESCRIPTION

PUMP, STEAM GENERATOR, GAS, 110V

ALL GAS MODELS

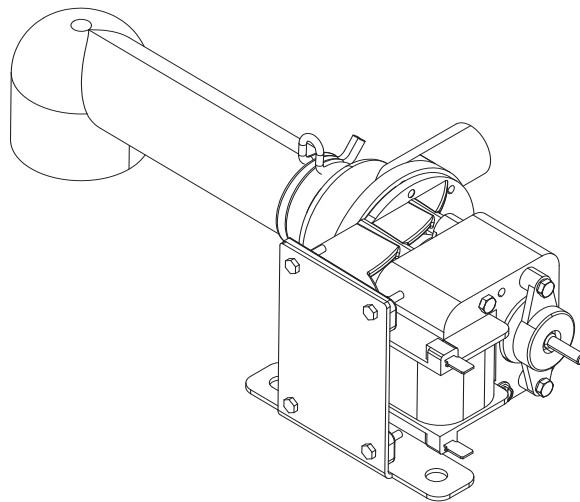
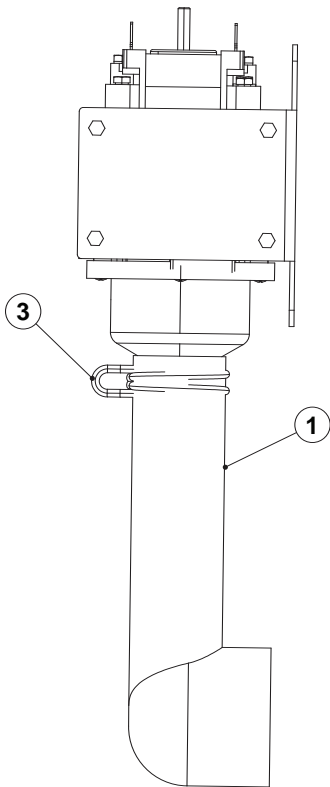
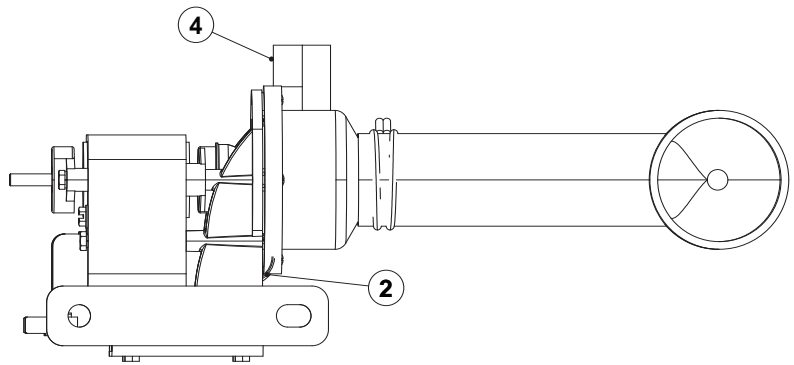
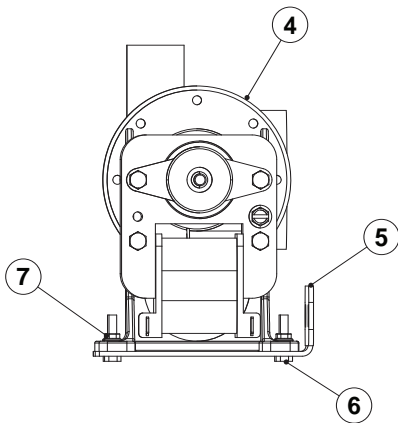

If pump is not white order S113231
If pump is white see next page.

ITEM	QTY	PART NO.	DESCRIPTION
1	1	C6015101	DRAIN ELBOW FOR STEAM GENERATOR
2	1	C6005299	SUPPORT BUSHING, STEAM GENERATOR - PUMP
3	1	C8009057	WIRE CLAMP D: 36, BLACK
4	1	300506	DRAIN PUMP WITH 110 V MOTOR
5	1	111630	BRACKET, PUMP, GAS GEN
6	4	111633	SCREW, HEX HD, M3 x 16, SST, FULLY THREADED
7	4	C8017008	NUT, LOCKING, SERRATED

Complete assembly S113231

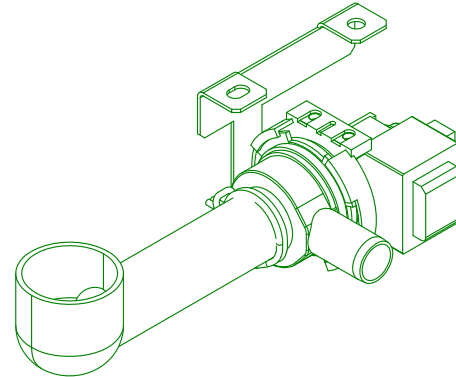
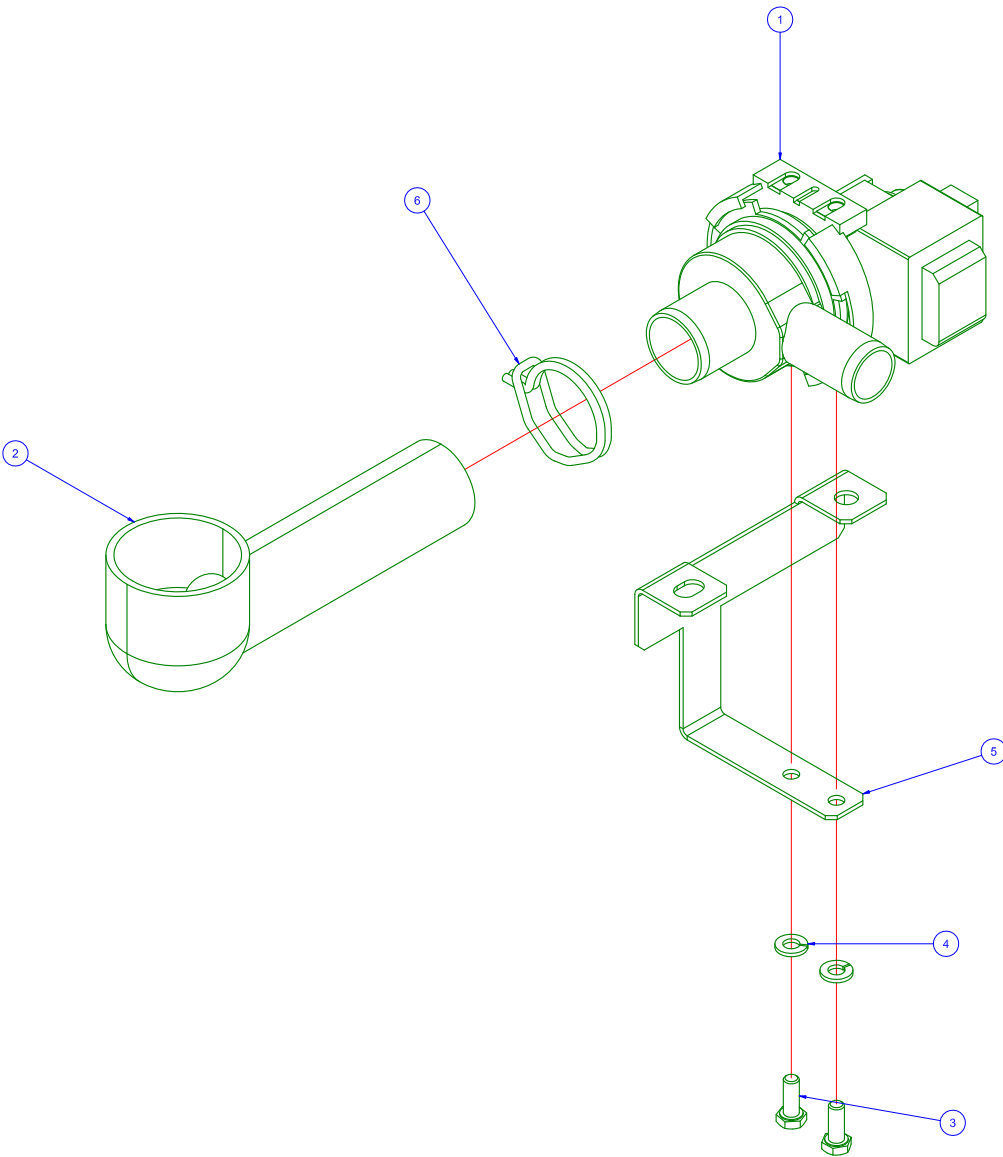

1	300753	Drain Pump 120 v
2	C6015101	Drain Elbow
3	C8003043	Hex Bolt M6x16
4	23105	Lock Washer
5	113269	Pump Bracket
6	107481	Hose Clamp

DOOR COMPLETE

20.20 MODELS

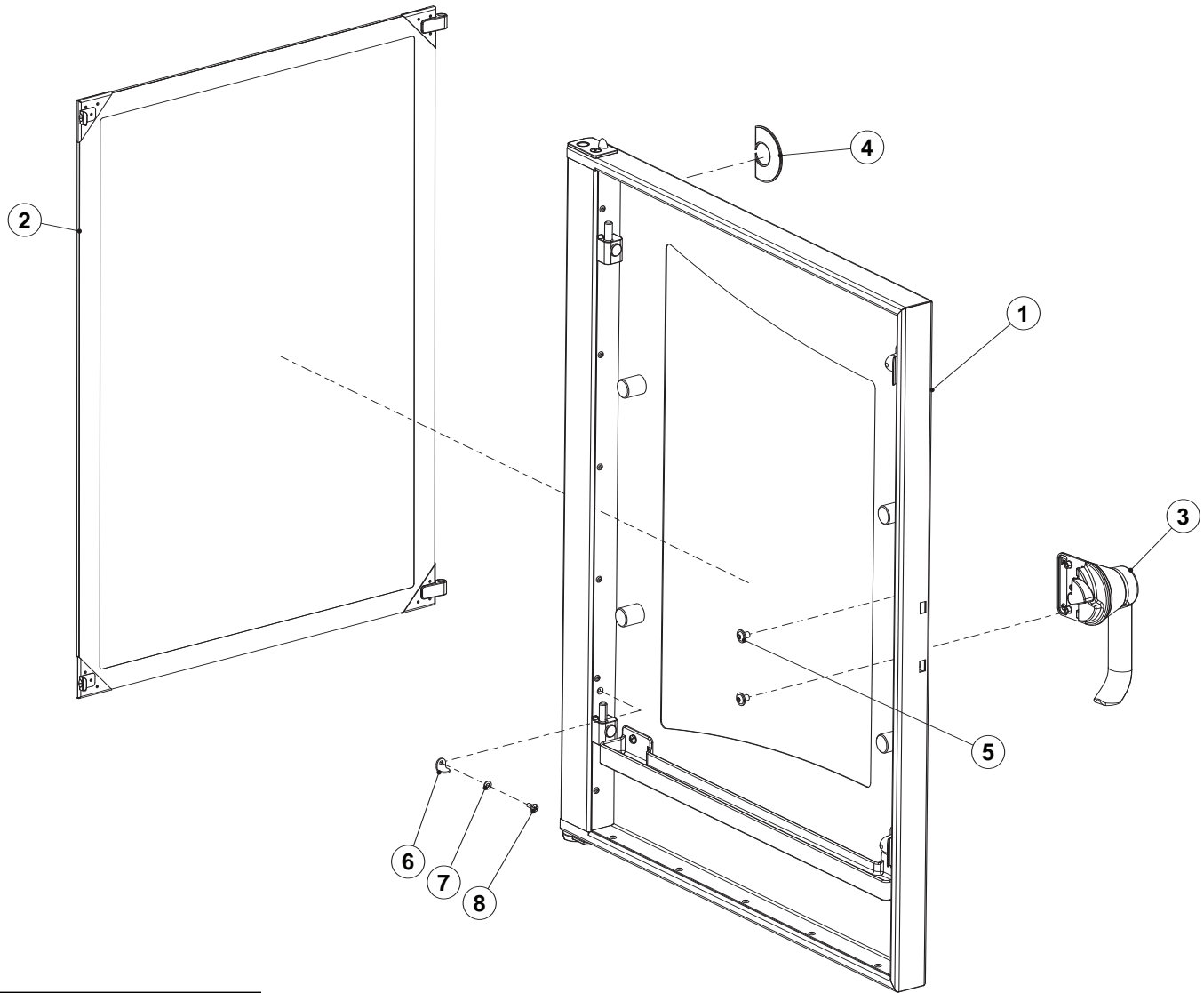

Complete Door C2514356

Cross Gasket C7001077

Spring clip C6015248

ITEM	QTY	PART NO.	DESCRIPTION
1	1	C2514363	ASSEMBLY, OUTER DOOR, 20.20
2	1	C2514394	ASSEMBLY, INNER DOOR, 20.20
3	1	C6012000	DOOR HANDLE, LOCKING
4	1	C6009016	PLASTIC LETTER "C" RED
5	2	C8015000	MLF SCREW M6X8
6	1	C2514430	UNHINGING SAFEGUARD, DOOR
7	1	C8001024	SCREW, FILISTER HD, M4x10 DIN 7985
8	1	C8005021	WASHER, 4.3, DIN 125
9	A/R	C7004012	LOCTITE 243 (NOT SHOWN)
10	A/R	C7003087	GREASE FRONT DOORS OD

DOOR ASSEMBLY 20.20

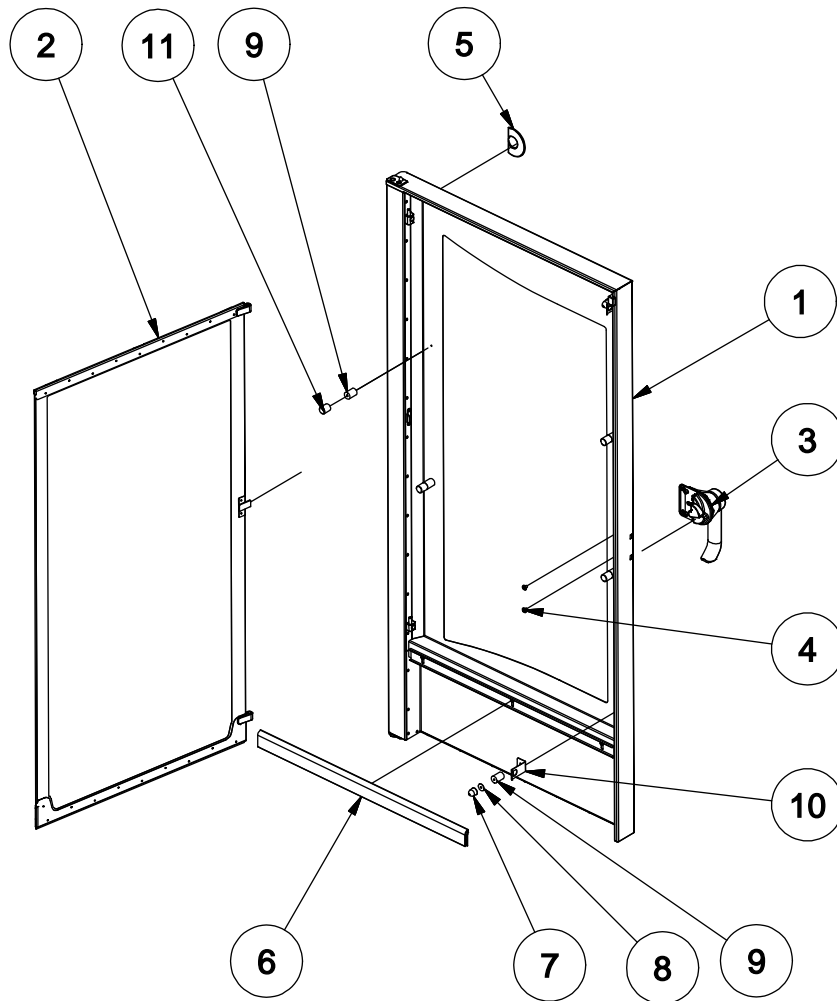

ITEM	QTY	PART NO.	DESCRIPTION
1	1	C2514363	ASSEMBLY, OUTER DOOR, 20.20
2	1	C2525465	ASSEMBLY, INNER DOOR, 20.20
3	1	C6012000	DOOR HANDLE, LOCKING
4	2	C8015000	MLF SCREW M6X8 A2
5	1	C6009016	PLASTIC LETTER "C" RED
6	1	C7001077	CROSS GASKET, DOOR
7	2	C2014005	SILICONE SPRING, DOOR
8	2	C2514439	WASHER, DOOR SPACER
9	6	C6015201	SPACER PIN, DOOR
10	2	C6015249	BRACKET, RETAINING DOOR, FLOOR MODELS
11	4	C6015200	SPACER BLOCK, DOOR

SLIDING PLATE, COMPLETE

ALL 6.20, 10.10 MODELS & 20.20 MODELS

Teflon Guide C6012016

Sliding Plate 20.20 C2614804

Upper Hinge C2013006

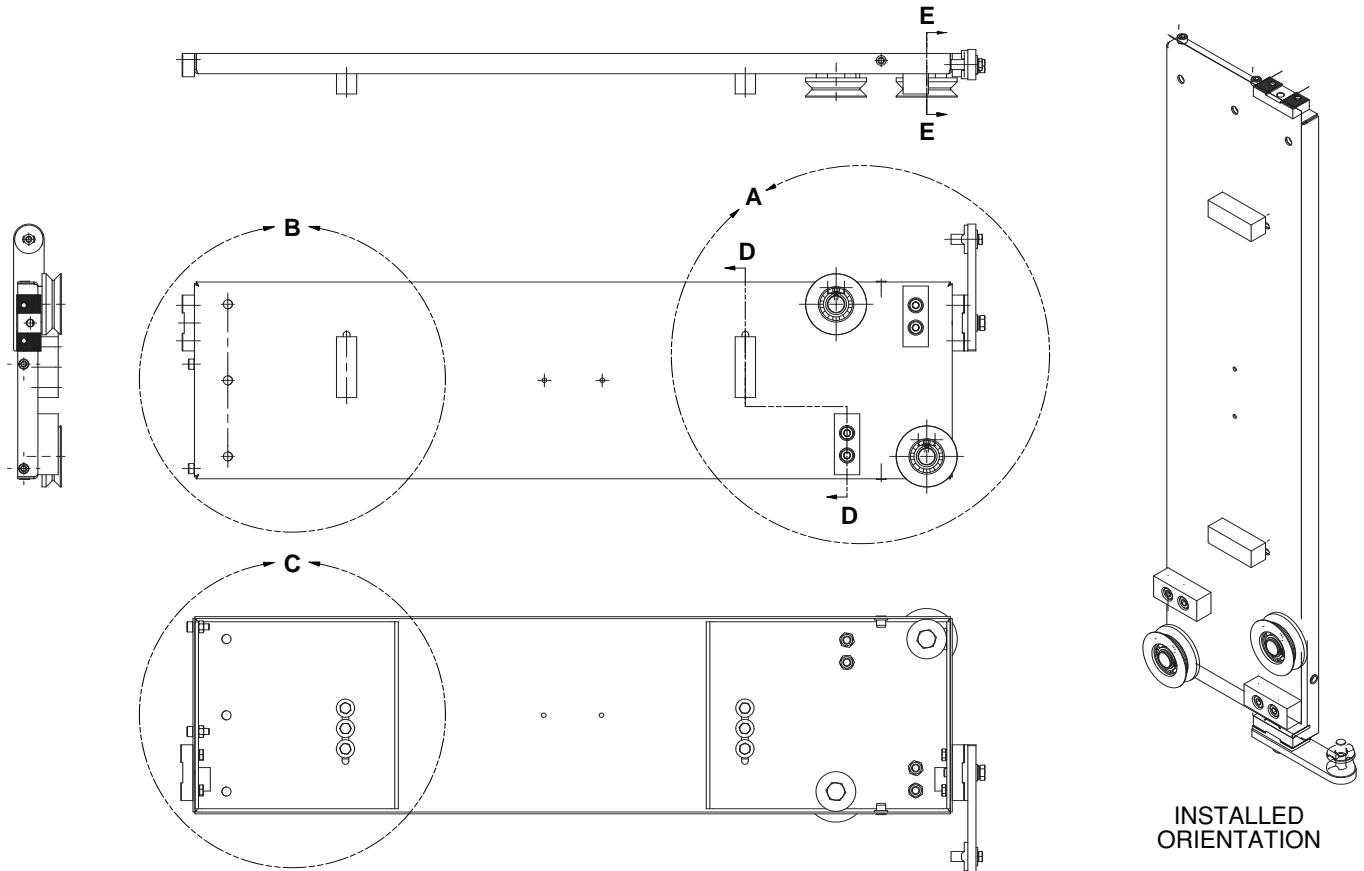

ITEM	QTY	PART NO.	DESCRIPTION
1	1	C2614806	CARRIAGE PLATE, WELDED, 6.20
		C2614807	CARRIAGE PLATE, WELDED, 10.10 & 10.20
		C2614809	CARRIAGE PLATE, WELDED, 20.10 & 20.20
2	2	C6012002	ASSEMBLED, GUIDE ROLLER RST CPL
3	2	C6012005	DISC \varnothing 39 x 6 RST
4	2	C2014008	LOCKING BLOCK, CARRIAGE PLATE
5	2	C6015226	LOCKING BLOCK RST
6	2	C6012006	DOOR STOP, RST
7	1	C2013004	HINGE, LOWER, WELDMENT, DOOR
8	11	C8006057	SCHNORR LOCK WASHER
9	2	C8006063	SCHNORR-LOCK WASHER
10	5	C8006060	SCHNORR LOCK WASHER
11	4	C8004057	NUT, HEX
12	1	C8005050	WASHER, 8.4 A2 DIN 125
13	1	C8003058	HEXAGON BOLT, M8 X 35
14	11	C8003043	HEXAGON BOLT M6x16
15	4	C8013002	FILLISTER HEAD SCREW DIN 912 - M8X25
16	2	C8008095	BLIND RIVET NUT M6 ROUND
17	2	C8001073	HEXAGON SOCKET SCREW M6x16
18	2	C8004040	HEXAGON NUT
19	1	C2014004	LOCKING PLATE, CARRIAGE, LOWER PART
20	7	C8005041	WASHER 6.4 A2 DIN 9021
21	A/R	C7004014	LOCTITE 638
22	2	C8003066	BOLT, HEX HD, M10x30, 6.20, 10.10 & 10.20
		C8013000	BOLT, HEX HD, M10x25, 20.10 & 20.20

SLIDING PLATE, COMPLETE

ALL 6.20, 10.10 MODELS & 20.20 MODELS

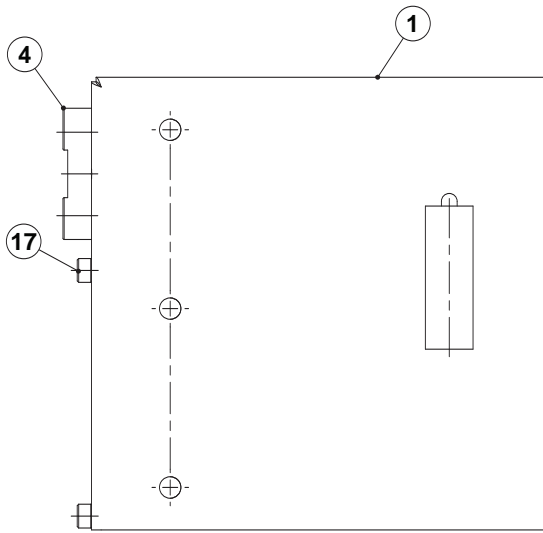

DETAIL B

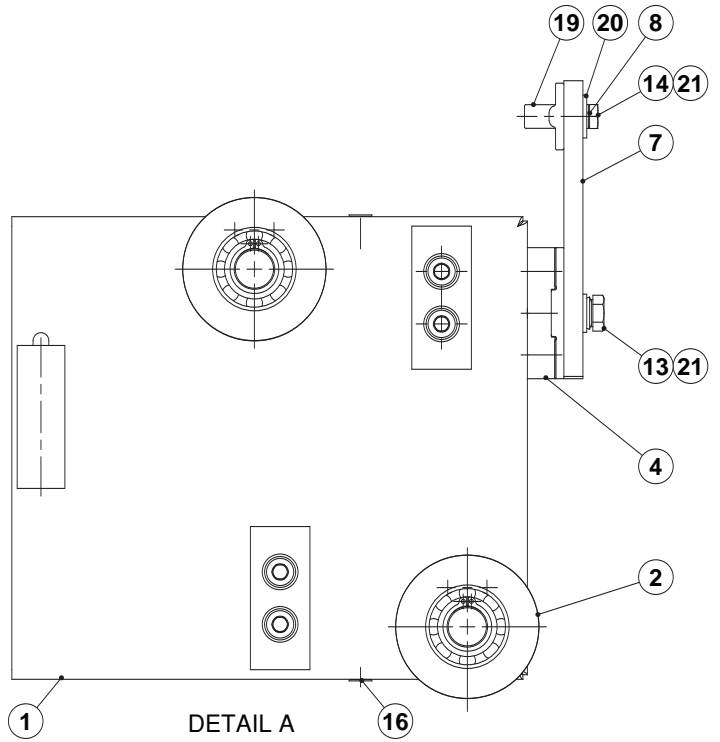

DETAIL A

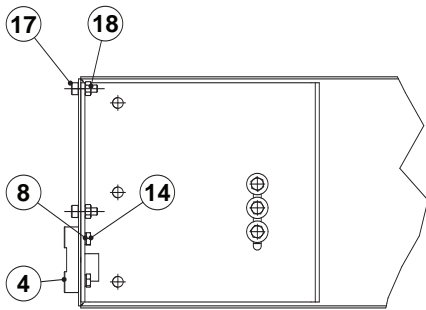

DETAIL C

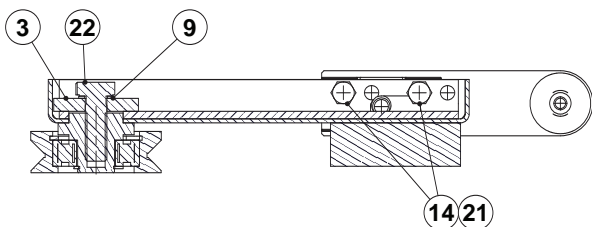

SECTION E-E

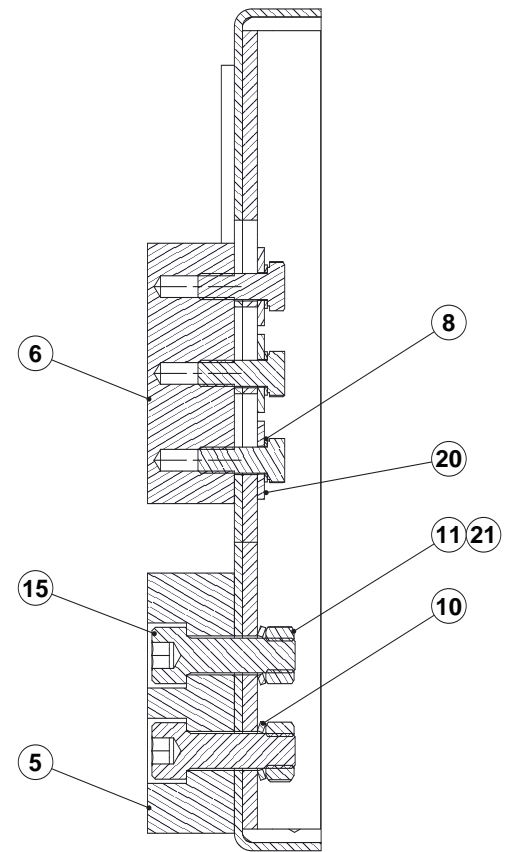

SECTION D-D

SLIDING PLATE ASSEMBLY

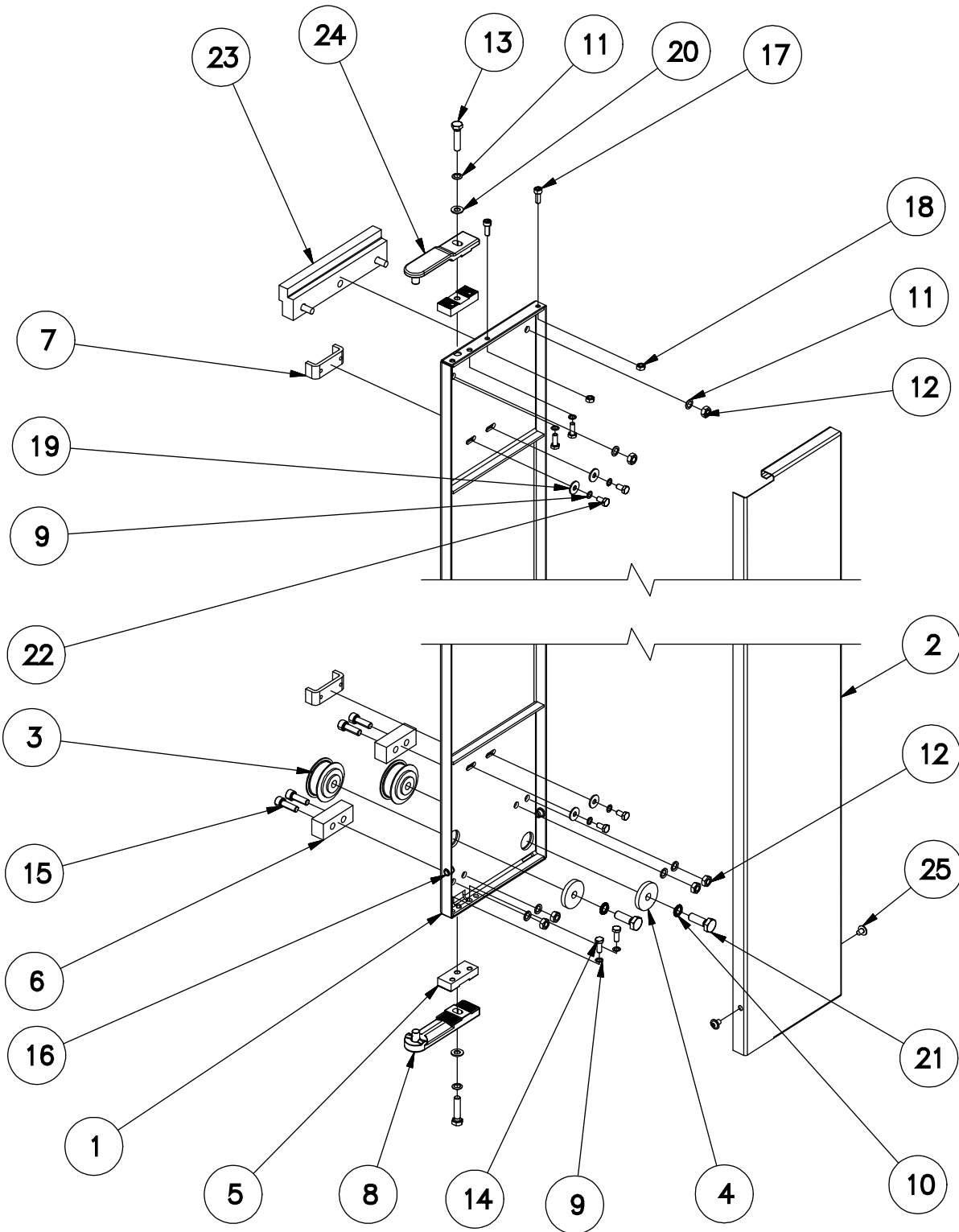

SLIDING PLATE ASSEMBLY

ITEM	QTY	PART NO.	DESCRIPTION
1	1	113069	SLIDING PLATE WELDMENT, 6.10
		113070	SLIDING PLATE WELDMENT, 10.10/10.20
		113071	SLIDING PLATE WELDMENT, 6.20
		113072	SLIDING PLATE WELDMENT, 12.20
		113073	SLIDING PLATE WELDMENT, 20.10/20.20
2	1	C2114815	COVER PANEL, 6.10
		C2114816	COVER PANEL, 6.20
		C2114817	COVER PANEL, 10.10/10.20
		C2114818	COVER PANEL, 12.20
		C2114819	COVER PANEL, 20.10/20.20
3	2	C6012017	ROLLER, ASSEMBLY, DOOR GUIDE
4	2	C6012005	DISC Ø39 x 6 RST P3
5	2	C2014008	LOCKING BLOCK, CARRIAGE PLATE, P3
6	2	C6015226	LOCKING BLOCK RST
7	2	C6012006	DOOR STOP, RST P3
8	1	C2013012	HINGE, DOOR, BOTTOM, CAST
9	8	C8006057	SCHNORR LOCK WASHER S6 A2 P3
10	2	C8006063	WASHER, BELLEVILLE, M10, SERRATED BOTH SIDES, SST
11	8	C8006060	SCHNORR LOCK WASHER, S8, A2, P3
12	6	C8004057	NUT, HEX, M8 A4
13	2	C8003058	HEXAGON BOLT, M8 X 35, A2 P2/P3
14	4	C8003043	HEXAGON BOLT M6x16 A2 P2/P3
15	4	C8013002	FILLISTER HEAD SCREW DIN 912 - M8X25 A2
16	2	C8008095	BLIND RIVET NUT M6 ROUND A2 P3
17	2	C8001073	HEXAGON SOCKET SCREW M6x16 A2 P2/P3
18	2	C8004040	HEXAGON NUT M6 A4 P2/P3
19	4	C8005041	WASHER 6.4 A2 DIN 9021 P2 P3
20	2	C8005050	WASHER, 8.4 A2 DIN 125 P3
21	2	C8003066	BOLT, HEX HD, M10x30, A2
22	4	C8013011	HEXAGON BOLT M6x12 A2 P2/P3
23	1	C6012016	SUPPORT STRIP VST P3
24	1	C2013013	HINGE, DOOR, TOP, CAST
25	2	C8015000	MLF SCREW M6X8 A2 P3

EXTERIOR SHEETING

ALL 20.20 MODELS

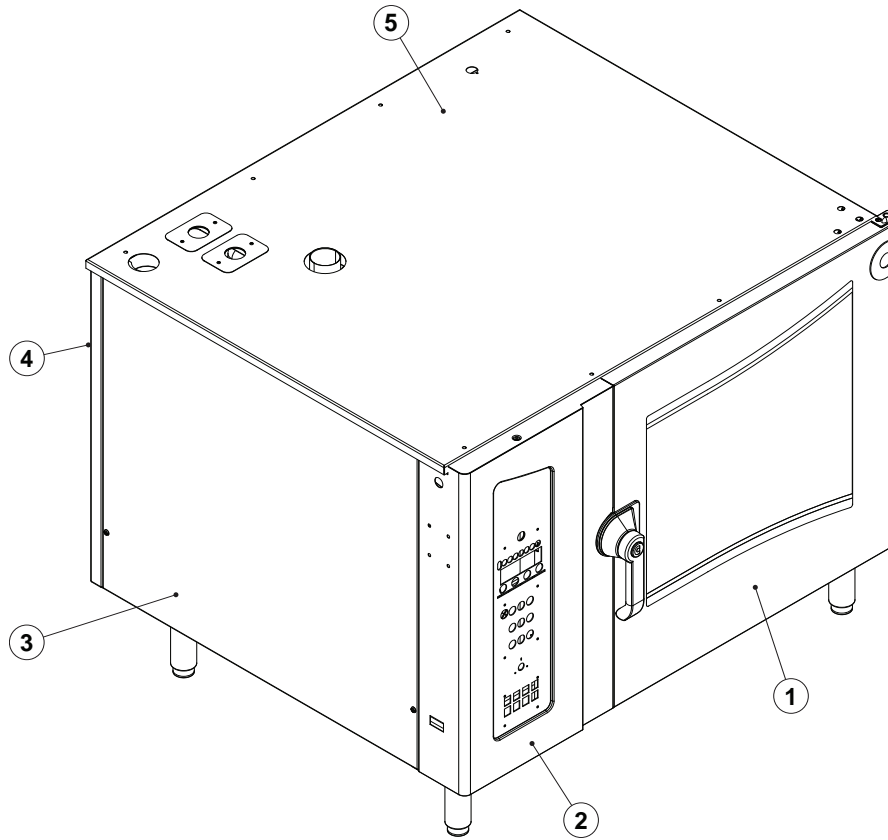

ITEM	QTY	PART NO.	DESCRIPTION
1	1	C2514356	DOOR, 20.20, COMPLETE
2	1	C2114657	WELDMENT, CORNER, FRONT LEFT, 20.20
3	1	C2114787	PANEL ASSY, LEFT, OGB 20.20, OGS 20.20, OEB 20.20, OES 20.20
4	1	C2114767	PANEL ASSY, REAR, OGB 20.20
-	1	C2114747	PANEL ASSY, REAR, OGS 20.20, OEB 20.20, OES 20.20
5	1	C2115467	PANEL, TOP, OGB 20.20
-	1	C2115457	PANEL, TOP, OGS 20.20
-	1	C2114704	PANEL, TOP, OEB 20.20
-	1	111665	PANEL, TOP, OES 20.20

PARTS LIST

<u>LABEL</u>	<u>DESCRIPTION</u>	<u>PART NO.</u>	<u>LABEL</u>	<u>DESCRIPTION</u>	<u>PART NO.</u>
-A10	CONTROL BOARD (SM 5010)	C5019100			
-A11	OPERATION BOARD (BM 5010)	C5019101	-U20	POWER BURNER ASSY, HOT AIR	-
-A12	PICTO BOARD (OPTION)	C5019105		FAN, BURNER, 120VAC	C5018007
-A13	I.D. MODULE	C5019102	-U21	POWER BURNER ASSY, GEN.	-
-A20	GAS BOARD (GM5010)	C5019103		FAN, BURNER, 120VAC	C5018007
-B1	WATER LEVEL PROBE	C5019003	-U22	POWER BURNER ASSY, HOT AIR.	-
-B3	CONDENSOR PROBE	C5016007		FAN, BURNER, 120VAC	C5018007
-B4	STEAM GEN PROBE	C5016007	-W1	CABLE, 9 PIN COM.	300533
-B5	BYPASS PROBE	C5016007	-Y1	VALVE, CONDENSER, 120VAC	300455
-B6	OVEN PROBE	C5016006		NOISE FILTER (RC)	300407
-B7.1	OVEN HI-TEMP THERMOSTAT	C5001041	-Y10	VALVE ASSY, 2 WAY, 120VAC	300456
-B7.2	GEN. HI-TEMP THERMOSTAT	1089952		-Y2 VALVE, DEHUMID.	-
-B8	GEN. HI-TEMP PROBE	C5016003		-Y3 VALVE, GEN. FILL	-
-B10	CORE TEMP. PROBE (KTM CTC)	C5013001		NOISE FILTER (RC)	-
-F1.1	FUSE, 3A	KE52936-6		VALVE ASSY, 3 WAY, 120VAC(CLEANING OPTION)	300363
-F2.1	FUSE, 1A	300418		-Y2 VALVE, DEHUMID.	-
-F10.1, -F10.2	FUSE, 20A	300471		-Y3 VALVE, GEN. FILL	-
-G1	POWER SUPPLY, 12VDC	300350		-Y21 VALVE, CLEAN/RINSE	-
-H5.1,-H5.2	OVEN LAMP	C5005043		NOISE FILTER (RC)	-
-K0	RELAY, 120VAC	03524	-Y20	PUMP, RINSING AGENT, 120VAC(CLEANING OPTION)	300352
	SOCKET	300473	-Y22	PUMP, CLEANING AGENT, 120VAC(CLEANING OPTION)	300352
-M1, M2	MOTOR, CONVECTION	C50180221	-Y23	PUMP, CLEANING AGENT, 120VAC(CLEANING OPTION)	300352
-M3.1,-M3.2	COOLING FAN	C5018023	-Z1,-Z2	LINE FILTER, 20A	300472
-M4	PUMP, GEN.	300506			
-N20	BURNER ASSY, HOT AIR	-			
	VALVE, GAS, 120VAC	C6016009			
	CONTROL, BURNER, 120VAC	C6016023			
-N21	BURNER ASSY, GEN.	-			
	VALVE, GAS, 120VAC	C6016009			
	CONTROL, BURNER, 120VAC	C6016023			
-N22	BURNER ASSY, HOT AIR	-			
	VALVE, GAS, 120VAC	C6016009			
	CONTROL, BURNER, 120VAC	C6016023			
-P1,-P2,-P3	FLAME SENSOR	C4018000			
-R20,-R21,-R22	IGNITOR, HOT SURFACE	C4018001			
-S1	SWITCH, CONTROL POWER	300278			
-S2	PRESSURE SWITCH	C5013051			
-S7	DOOR SWITCH	C5003075			
-T1	TRANSFORMER, 120V/24V	300419			
-T2	TRANSFORMER, 120V/24V	300419			
-T3	TRANSFORMER, 120V/24V	300419			
-U10.1, -U10.2	AC DRIVE	300462			

OGB 20.20 Parts List

PARTS LIST

<u>LABEL</u>	<u>DESCRIPTION</u>	<u>PART NO.</u>	<u>LABEL</u>	<u>DESCRIPTION</u>	<u>PART NO.</u>
-A10	CONTROL BOARD (SM 5010)	C5019100			
-A11	OPERATION BOARD (BM 5010)	C5019101	-U20	POWER BURNER ASSY, HOT AIR	-
-A12	PICTO BOARD (OPTION)	C5019105		FAN, BURNER, 120VAC	C5018007
-A13	I.D. MODULE	C5019102	-U22	POWER BURNER ASSY, HOT AIR.	-
-A20	GAS BOARD (GM5010)	C5019103		FAN, BURNER, 120VAC	C5018007
-B3	CONDENSOR PROBE	C5016007	-W1	CABLE, 9 PIN COM.	300533
-B4	STEAM GEN PROBE	C5016007	-Y1	VALVE, CONDENSER, 120VAC	300455
-B5	BYPASS PROBE	C5016007		NOISE FILTER (RC)	300407
-B6	OVEN PROBE	C5016006	-Y10	VALVE ASSY, 2 WAY, 120VAC	300456
-B7,1	OVEN HI-TEMP THERMOSTAT	C5001041		-Y2 VALVE, DEHUMID.	-
-B10	CORE TEMP. PROBE (KTM CTC)	C5013001		-Y3 VALVE, GEN. FILL	-
-F1,1	FUSE, 3A	KE52936-6		NOISE FILTER (RC)	-
-F2,1	FUSE, 1A	300418		VALVE ASSY, 3 WAY, 120VAC(CLEANING OPTION)	300363
-F10.1, -F10.2	FUSE, 20A	300471		-Y2 VALVE, DEHUMID.	-
-G1	POWER SUPPLY, 12VDC	300350		-Y3 VALVE, GEN. FILL	-
-H5,1,-H5,2	OVEN LAMP	C5005043		-Y21 VALVE, CLEAN/RINSE	-
-K0	RELAY, 120VAC	03524		NOISE FILTER (RC)	-
	SOCKET	300473	-Y20	PUMP, RINSING AGENT, 120VAC(CLEANING OPTION)	300352
-M1, M2	MOTOR, CONVECTION	C50180221	-Y22	PUMP, CLEANING AGENT, 120VAC(CLEANING OPTION)	300352
-M3,1,-M3,2	COOLING FAN	C5018023	-Y23	PUMP, CLEANING AGENT, 120VAC(CLEANING OPTION)	300352
-N20	BURNER ASSY, HOT AIR	-	-Z1,-Z2	LINE FILTER, 20A	300472
	VALVE, GAS, 120VAC	C6016009			
	CONTROL, BURNER, 120VAC	C6016023			
-N22	BURNER ASSY, HOT AIR	-			
	VALVE, GAS, 120VAC	C6016009			
	CONTROL, BURNER, 120VAC	C6016023			
-P1,-P3	FLAME SENSOR	C4018000			
-R20,-R22	IGNITOR, HOT SURFACE	C4018001			
-S1	SWITCH, CONTROL POWER	300278			
-S2	PRESSURE SWITCH(PUMP)	C5013051			
-S3	PRESSURE SWITCH(INJECTION)	C5009063			
-S7	DOOR SWITCH	C5003075			
-T1	TRANSFORMER, 120V/24V	300419			
-T3	TRANSFORMER, 120V/24V	300419			
-U10.1, -U10.2	AC DRIVE	300462			

OGS 20.20 Parts List