



JOB:
ITEM:
QTY:



97055-OVAL TRAY DOLLY

SPECIFICATIONS

MATERIAL: Hi-tensile, corrosion resistant, rust proof, primary extruded aluminum, Type 6463-T5 alloy.

CONSTRUCTION: All heli-arc welded with all seams welded and sealed (no rivets).

BASE: Rectangular base of 2" x 2" X 3/16" thick extruded aluminum angle welded into rigid framework. At each corner a caster plate 2 3/4" x 4" x 3/8" thick, pre-tapped for 1/4" bolts is securely welded to the base. A "V" shaped rod (3/8" thick) is welded to the front underside of the base to accept a drag hook. .080" sheet forms a removable base to hold oval trays.

SIDES & HANDLE: Unit has three sides consisting of 1" x 1" x .070 wall extruded aluminum tubing welded securely to the base. The tubing sides use gussets of 1/4" x 1 1/2" strap (welded from tube to base) for extra strength and rigidity. Tubing on rear of unit extends 5" above the sides and is formed into a handle, from the center of the handle to the base. A pan stop of 1/4" x 1" strap is welded into place. **Note: All tubing has rounded corners and all seams are fully welded.**

CASTERS: Four platform type 5" casters, full swivel design with ball bearing axle and non-marking wheels. Load Capacity = 290# each.



Model #97055



Phone:800-255-0104
Fax: 877-877-7687
www.newageindustrial.com
sales@newageindustrial.com

New Age Industrial reserves the right to modify or make changes at any time without notice to materials and specifications.

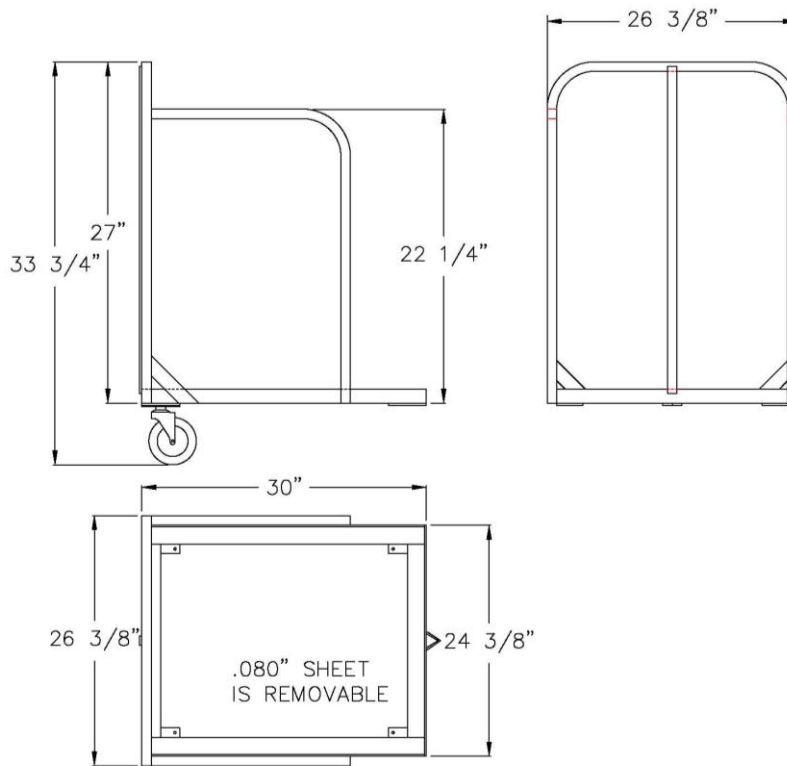

Model #97055

Model No.	Size-W	Size-H	Size-D	Wt. Cap.
97055	26 3/8"	33 3/4"	30"	800#



Phone: 800-255-0104
 Fax: 877-877-7687
www.newageindustrial.com
sales@newageindustrial.com

New Age Industrial reserves the right to modify or make changes at any time without notice to materials and specifications.