

HOBART701 S Ridge Avenue, Troy, OH 45374
1-888-4HOBART • www.hobartcorp.com**4146
MEAT GRINDER****HOBART****STANDARD FEATURES**

- 5 H.P. motor
- Magnetic starter
- 215 RPM transmission
- No. 46 wide-mouth grinding end
- 14 gauge tinned steel feed pan
- Waterproof junction box
- Metallic gray epoxy finish
- 16" galvanized steel legs
- Grinding end
- High back
- Stainless steel deflector
- Plastic feed stomper
- Wrench

OPTIONS

- Optional Leg lengths
 - 8½", 11½", 14¾", 16", 18½", 20", 21", 22", 23", 24½", 26", 27½", 28½", 30", 31½" or 33½"

**MODEL**

- 4146 – Meat Grinder

ACCESSORIES

- 14 gauge stainless steel fed pan
- No. 32 knives & plates
- Stainless steel finish

Specifications, Details and Dimensions on Inside and Back.

**With Deflector****Without Deflector****4146 MEAT GRINDER**

4146 MEAT GRINDER



701 S Ridge Avenue, Troy, OH 45374
1-888-4HOBART • www.hobartcorp.com

LISTED BY: UNDERWRITERS LABORATORIES INC and NSF INTERNATIONAL.

SPECIFICATIONS

GENERAL: The Model 4146 grinds fresh or tempered frozen meat (above 26°F). This grinder is designed for the fast, clean cutting of meat where high-quality ground products are of prime importance.

MOTOR: Hobart designed 5 H.P., heavy duty. Front ball bearing receives oil lubrication from transmission. Rear ball bearing is grease-packed, sealed for life. Ventilation is provided through screened openings in base.

ELECTRICAL: 200/60/3, 230/60/3 and 460/60/3 — UL Listed. 220/50/3 and 380/50/3 — Not submitted for UL Listing.

MOTOR CONTROLLER: Magnetic starter featuring automatic resetting bimetallic thermal overload protection. Starter is mounted inside machine enclosure and actuated by rubber-capped pushbuttons located on right side of machine for standard right-to-left operation. For applications above 250 volts, a transformer is furnished to reduce voltage for use in the electrical interlock and control circuit.

TRANSMISSION: Geared, double reduction, consisting of oil-lubricated hardened helical cut steel gears. Worm speed is 215 RPM. Thrust from grinder worm is taken by a large tapered roller bearing mounted in attachment hub on face of transmission housing. Double seals prevent loss of oil or entrance of moisture.

GRINDER END: This unit is supplied with a No. 46 wide-mouth grinding end with a separate cast-iron bowl. The cylinder is removable when the pan is unclamped and raised to rest on a support provided to hold it in a tilted position. The grinding end is mounted to the transmission on two studs. It can be removed easily by loosening two cylinder nuts and rotating the cylinder a few degrees until the mounting flange clears the nuts. The cylinder is a spiral fluted type, equipped with a deep-fluted worm, designed for standard No. 32 knives and plates (not furnished). The cylinder, bowl, worm, and adjusting ring are heavily tinned cast iron.

CAPACITY: The Model 4146 Grinder has a fresh beef capacity of 60 to 65 pounds per minute, first cutting, through a 1/8" plate and 45 to 50 pounds of beef per minute, second cutting, through a 1/8" plate.

SAFETY SYSTEM: Model 4146 Grinder combines operator safety with maximum capacity. A cast aluminum guard is permanently mounted to

the sides of the pan. This guard, plus the unique bowl design, protects from accidental contact with the worm. An electrical interlock system is provided which shuts off current to the motor as soon as the pan is separated from the cylinder. This interlock prevents the machine from running or being started when the bowl is not in position on the cylinder. Both the bowl and the pan must be in their proper operating locations before the machine can be started.

FEED PAN: Feed pan features large capacity and high back (9"), measures 49" long, 26 3/4" wide, and 4 1/2" deep at front edge. Furnished in heavily tinned 14 gauge steel—or available (at extra cost) in 14 gauge stainless steel. Cast aluminum guard, assuring ease of feeding along with maximum safety, is mounted to the sides of the pan with hardened steel drive screws.

LEGS: Standard leg length (16") provides 2 1/4" clearance between floor and lowest point on adjusting ring. One leg is adjustable for leveling. Legs are galvanized steel with epoxy finish. Optional leg lengths that are available — 8 1/2", 11 1/2", 14 3/16", 16", 18 1/2", 20", 21", 22", 23", 24 1/2", 26", 27 1/2", 28 1/2", 30", 31 1/2", 33 1/2".

STANDARD EQUIPMENT: Consists of working power unit with magnetic-type starter and pushbuttons completely wired to motor; waterproof junction box on rear of machine requiring only power connection; Hobart grinding end; high back, large-capacity tinned feed pan with guard; tinned steel meat deflector mounted to grinding end; plastic feed stomper; wrench (for loosening cylinder nuts); 16" legs. This unit uses No. 32 knives and plates (not furnished).

FINISH: The housing is available in durable Hobart metallic gray epoxy finish or in stainless steel (at extra cost).

SANITATION: The motor and transmission are totally enclosed by housing and base plate. Two openings in the base screened with perforated metal provide ventilation for the motor. All machine parts that have direct contact with the product are easily removed for cleaning or easily cleaned in place. The machine surfaces are smooth and free of unnecessary edges, cracks, and screw heads to simplify cleaning.

WEIGHTS: Net 510 pounds, shipping 569 pounds.

DETAILS AND DIMENSIONS

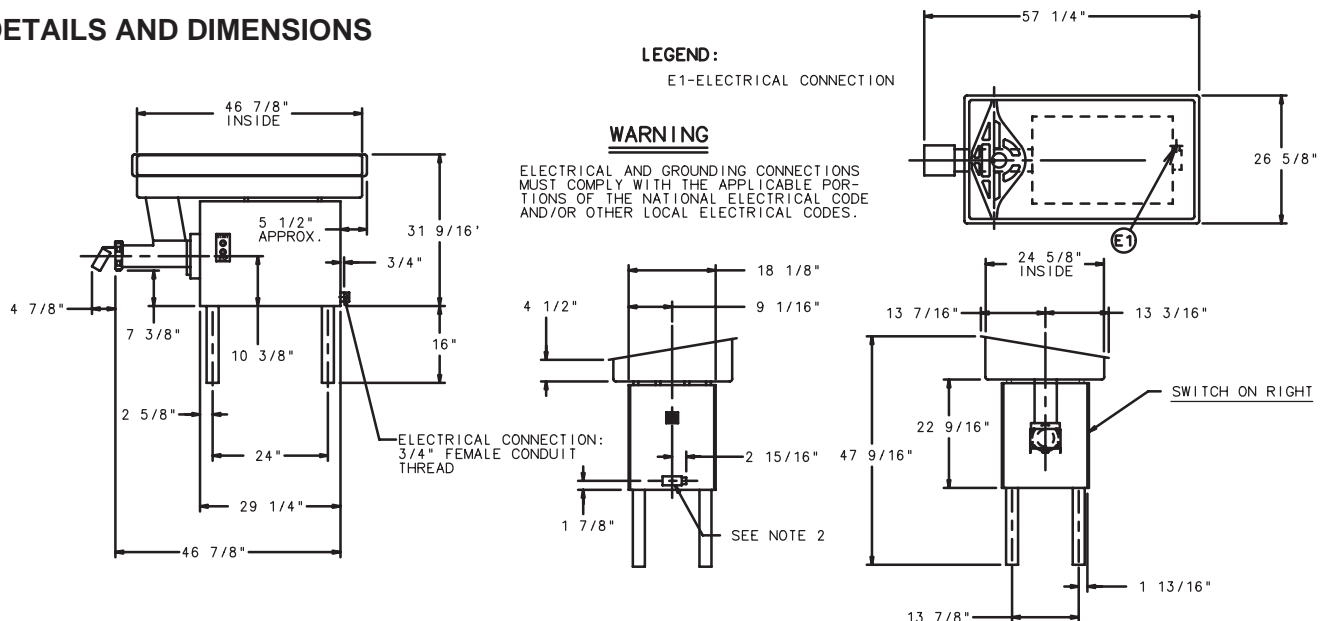

As continued product improvement is a policy of Hobart, specifications are subject to change without notice.