

HOBART701 S Ridge Avenue, Troy, OH 45374
1-888-4HOBART • www.hobartcorp.com**3713/3713N
SLICER****HOBART****STANDARD FEATURES**

- Low Profile, Linear Automatic Drive
- Removable Knife (3713)
- Non-Removable Knife (3713N)
- Removable Ring Guard Cover
- Zero Knife Exposure
- Three Automatic Speed Settings
- Manual Assist Mode
- Enduralube™ Carriage Rail System
- Tilting, Removable Carriage System
- 13" CleanCut™ Knife
- Top Mounted Borazon Stone Sharpener
- Glass Bead Finish on Gauge Plate, Top Knife Cover and Product Tray
- MICROBAN® Antimicrobial Product Protection
- Double-Action Indexing Barrel Cam
- Cleaning Leg
- Rear Mounted Meat Grip
- Ergonomic Style Handle
- ½ H.P. PSC Knife Drive Motor
- Burnished Aluminum Base
- 10 Rib Poly V-Belt Drive System

MODEL

- 3713 – Full Featured Automatic Slicer with Removable Knife and Tool
- 3713N – Full Featured Automatic Slicer with Non-Removable Knife

ACCESSORIES

- Knife Removal Tool
- Full Fence
- End Fence
- Food Chute
- Product Deflector
- 4" Legs

Specifications, Details and Dimensions on Inside and Back.

**3713/3713N SLICER**

3713/3713N SLICER



701 S Ridge Avenue, Troy, OH 45374
1-888-4HOBART • www.hobartcorp.com

SOLUTIONS / BENEFITS

Linear Automatic Drive with Three Speeds

Labor savings, lower maintenance costs

- Drive system uses magnets and electricity to move product back and forth
- Reduces moving parts and lowers profile of automatic models
- Three carriage speeds including 30, 42 and 52 strokes per minute

Removable Knife (3713)

Easier cleaning, labor savings

- Knife easily removes with optional tool
- Area within ring guard is open for faster cleaning
- Knife and tool are warewasher safe for easy cleaning and sanitation

Removable Ring Guard Cover

Reduces labor, easier to clean

- Catches product debris around the knife for easy removal during cleaning
- Reduces time to “floss” during cleaning

Zero Knife Exposure

Looking out for the operator

- Knife edge is covered when sharpener is both mounted, removed making cleaning easier
- Gauge plate remains closed during operation of sharpener to keep knife edge covered

Manual Mode Assist

Ease of use, improved slicing performance

- Reduces operator effort needed to move carriage when slicing manually

Enduralube™ Carriage Rail System

Performance, durability, lower maintenance

- Smooth operation from continuous lubrication of carriage rod
- Replenish only once a year to maintain performance

Exclusive Tilting, Removable Carriage System

Easier to clean, reduces labor

- Tilt design allows for ease of midday cleaning
- Removable for complete cleaning and sanitation

CleanCut™ Knife

Reduces cost of ownership, improves yield

- Thin edge design improves yield
- Super alloy edge stays sharp longer

Top Mounted Borazon Stone Sharpener

Ease of use, easier cleaning, reduces costs

- Single action sharpens and hones in just five seconds

- Removable and warewasher safe for easy cleaning and sanitation
- Lifetime guaranteed Borazon sharpening stones provide maximum performance with reduced maintenance costs

Glass Bead Finish on Gauge Plate and Knife Cover

Ease of use, improves performance

- Reduces drag for a smoother slicing motion

MICROBAN® Antimicrobial Product Protection

Easier cleaning

- Inhibits the growth of odor and stain causing organisms on the plastic touch points

Double-Action Indexing Barrel Cam

Increases reliability, easier to use

- Indexing numbers are consistent across machines and over time
- The first full revolution of the indexing knob provides precise control for shaving, chipping and thin slicing
- The second revolution opens the gauge plate quickly for thicker slicing

Cleaning Leg

Ease of use and cleaning

- Cleaning leg holds machine at an incline to allow for cleaning underneath

Rear Mounted Meat Grip

Slicing performance, ease of use

- Opens up front of product tray for unobstructed loading
- Optimizes geometry and weight for better hold

Ergonomic Style Handle

Operator satisfaction

- Comfortable manual operation

½ H.P. PSC Knife Drive Motor

Durability, cost savings

- More efficient design reduces energy cost

Burnished Aluminum Base

Easier cleaning, labor savings

- Limited cracks/crevices or bolt holes where product can lodge and bacteria may grow
- Easy cleanup

10 Rib Poly V-Belt Drive System

Reduces maintenance, improves efficiency

- Improves energy transfer from motor to knife
- Quieter operation



701 S Ridge Avenue, Troy, OH 45374
1-888-4HOBART • www.hobartcorp.com

3713/3713N SLICER

SPECIFICATIONS

Linear Automatic Drive: Mounts directly on carriage rail to deliver smooth, quiet carriage movement without moving parts.

Removable Knife: Knife hub accepts Knife Removal Tool. The tool covers the knife edge when removed (3713). Non-removable knife can be ordered as 3713N.

Removable Ring Guard Cover: Cover fits on top of ring guard to catch food debris. When removed, reveals a 0.12" space between knife and guard for easier flossing. Is durable Celcon™ plastic and can be washed in ware-washer or three compartment sink.

Zero Knife Exposure: Knife edge is not exposed during slicing or recommended cleaning procedures.

Manual Mode Assist: Linear drive assists as user pushes and pulls carriage while slicing manually.

Enduralube™ Carriage Rail System: Enduralube™ ensures optimal lubrication of carriage rail and bearings while requiring only annual oil replenishment.

Tilting, Product Tray Carriage System: Stainless steel and aluminum product tray tilts easily for midday cleaning and is removable for thorough cleaning and sanitation procedures. The carriage has 12½" manual travel.

CleanCut™ 13" Knife: The knife is approximately 13 inches, constructed of 304L stainless steel and high performance Stellite™ alloy. Knife cover is quickly removed with a quarter turn of the spring loaded locking knob mounted directly on the cover.

Top Mounted Borazon Stone Sharpener: Single action operation utilizing two Borazon stones to sharpen and hone in five seconds. Removable, top mounted and warewash safe. When sharpener is removed for cleaning, knife edge is completely shielded. Borazon stones have lifetime guarantee.

Glass Bead Finish on Gauge Plate and Top Knife Cover: Glass bead finish creates micro-dimples in the surface to reduce friction.

MICROBAN® Antimicrobial Product Protection: The Microban additive is built into the external plastic components to inhibit the growth of stain and odor causing organisms. The additive is designed to last the life of the products in which it is incorporated and works continuously to maintain a lower level of odor and stain causing microorganisms. Microban® does not protect

the user against food-borne bacteria. Always maintain good hygiene practices.

Double-Action Indexing Barrel Cam: Index knob moves the gauge plate via a barrel cam ensuring consistent slice thickness across machines and over time. First revolution of index cam for precision slicing; second revolution for thicker slicing selection.

Cleaning Leg: Cleaning leg helps to hold slicer in tilted position for cleaning beneath the machine.

Ergonomic Style Handle: Specially shaped and positioned for ease of use during manual operation.

½ H.P. PSC Knife Drive Motor: Permanently lubricated ball bearings. Single Permanent Split Capacitor motor (PSC).

Burnished Aluminum Base: One-piece base inhibits growth of bacteria in seams, cracks and crevices. Limits holes or crevices in which food can lodge.

10 Rib Poly V-Belt Drive System: Knife is driven by a Poly V belt with ten ribs for optimal efficiency and power transfer.

Finish: Stainless steel product tray, gauge plate and top knife cover. Burnished aluminum base and product tray support arm.

Meat Grip: Rear mounted grip is high strength thermo-plastic. Swings out of way when not in use.

Product Deflector: Deflects large, thick slices off of motor mount. Recommended when slicing product that is both thicker than ¾" and larger in diameter than 5½".

Electrical Specification: 100-120/60/1. Also available in 200-240/50/60/1 (2.5 amps).

Switch: Moisture protected membrane, operated by sealed push-button switches.

Slice Thickness: Up to 1¼ inches.

Cord & Plug: 6-foot, three-wire power supply cord and flat plug. Plug not furnished on export models.

Capacity: The product tray will take food up to –
Rectangle: approximately 12" x 6" or
Round: approximately 8" diameter.

Warranty: All parts and service coverage for one year including knife. Lifetime guarantee on Borazon stones in the sharpening system.

Weight: Shipping 142 lbs., Net 110 lbs.

Microban® does not protect the user against food-borne illness. Always maintain good hygiene practices.

3713/3713N SLICER



701 S Ridge Avenue, Troy, OH 45374
1-888-4HOBART • www.hobartcorp.com

DETAILS AND DIMENSIONS

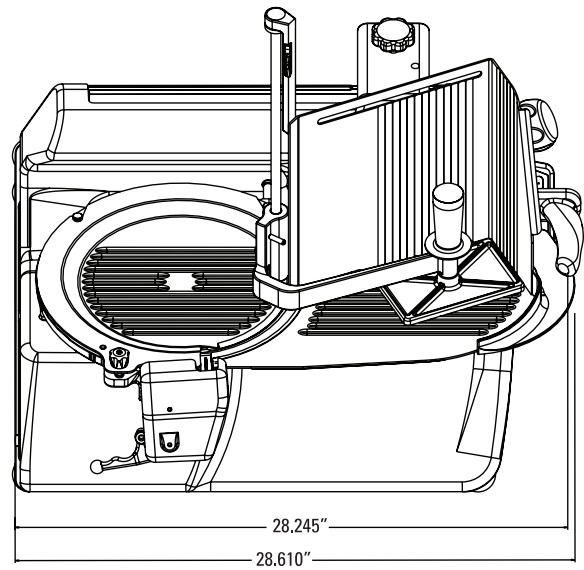
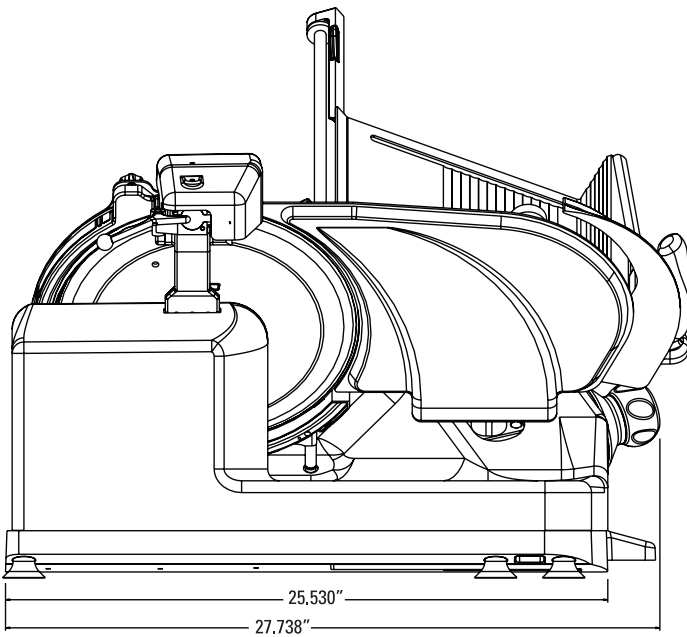
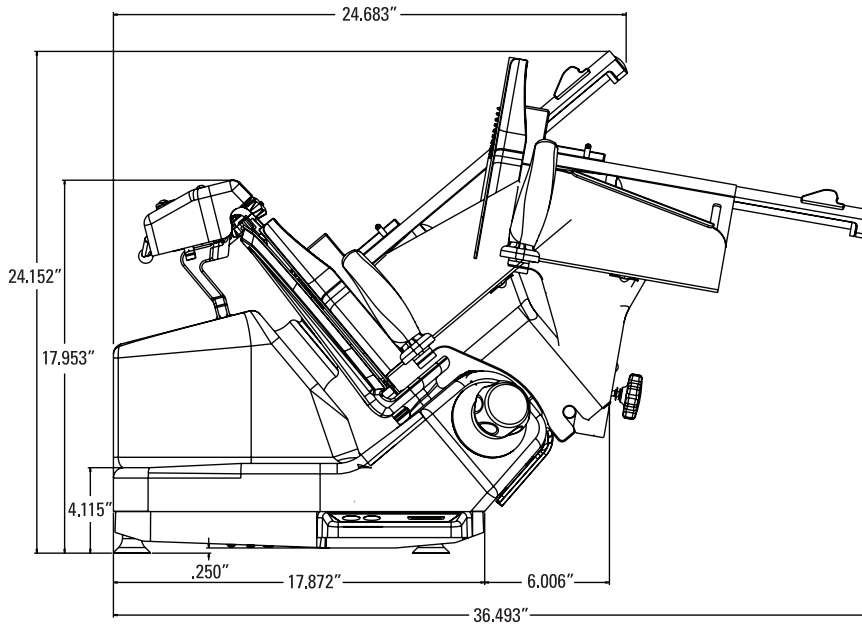

Microban and the Microban symbol are registered trademarks of the Microban Products Company, Huntersville, NC.

As continued product improvement is a policy of Hobart, specifications are subject to change without notice.