

**HOBART**701 S Ridge Avenue, Troy, OH 45374  
1-888-4HOBART • www.hobartcorp.com**84145  
FOOD CUTTER****HOBART****STANDARD FEATURES**

- ½ H.P. Motor
- 14" Stainless Steel Bowl
- One-piece Burnished Aluminum Housing
- 1725 RPM Knife Rotation
- Bowl Cover Safety Interlock
- 22 RPM Bowl Rotation
- Pull/Push On/Off Switch
- Double Cutlery Grade Stainless Steel Knives
- 3" Stainless Steel Legs With Rubber Feet
- 6' Flexible Cord and Plug

**OPTIONS**

- #12 Attachment Hub

**ACCESSORIES**

- Vegetable Slicer
- Meat Chopper Attachment

**MODELS**

- 84145 – Food Cutter with 14" Stainless Steel Bowl, Double Cutlery Grade Stainless Steel Knives with Stainless Steel Knife Comb and 3" Stainless Steel Legs with Rubber Feet.
- 84145C – Maximum Security Correctional Package (115/60/1, with attachment hub only)

Specifications, Details and Dimensions on Reverse Side

**84145 FOOD CUTTER**

# 84145 FOOD CUTTER



701 S Ridge Avenue, Troy, OH 45374  
1-888-4HOBART • www.hobartcorp.com

## SOLUTIONS/BENEFITS

### ½ H.P. Motor

Durability, Reliability

- Heavy-duty to meet the most demanding operations

### Bowl Cover Safety Interlock

Safety

- Machine cannot be turned on until the bowl cover is locked down into position
- Bowl cover cannot be raised with the switch in the "ON" position

### One-piece Burnished Aluminum Housing

Durability, Sanitation

- One-piece base has no cracks or crevices to allow food product to hide

### Removable Bowl Cover, Knives and Bowl Without the Use of Tools

Ease of Cleaning, Ease of Use

- Easily removed to be taken to three compartment sink for thorough cleaning
- No tools needed to remove means less time and labor involved

### Double Cutlery Grade Stainless Steel Knives

Durability, Performance

- Reduce food products to a uniformly small particle size for salads, spreads, bread crumbs and other imaginative recipes
- Holds an edge longer resulting in fewer sharpenings

## SPECIFICATIONS

**MOTOR:** ½ H.P., fan cooled, permanently lubricated ball bearings, and totally enclosed within the machine. Single-phase is capacitor-start, induction-run. Three-phase is induction run.

**ELECTRICAL:** Available in 115/60/1 and 230/60/1.

**SWITCH:** Single-phase is double-pole single throw. Three-phase is three-pole single throw. The bowl cover and switch are interlocked so that the machine cannot be turned on until the bowl cover is locked in place, nor can the bowl cover be raised with the switch in the "ON" position.

**CORD AND PLUG:** 6 foot cord with plug per latest NEMA configuration.

**BOWL:** Rotates at 22 R.P.M. 14<sup>15/16</sup>" inside diameter. Formed from a single sheet of stainless steel and easily removed for cleaning.

**KNIVES:** Rotate at 1725 RPM. The blades (made of special cutlery grade stainless steel) are secured to a hub as a unit, which may be removed from the knife shaft without change of knife clearance adjustment. Stainless steel knife comb included.

**BASE:** One-piece burnished aluminum casting with steel bottom cover (total enclosure).

**STANDARD EQUIPMENT:** Consists of Food Cutter with 14" stainless steel bowl, cutlery grade stainless steel knives with stainless steel knife comb and 3" stainless steel legs with rubber feet.

**ATTACHMENT HUB:** Speed-209 RPM. Accommodates all Hobart No. 12 attachments.

**ACCESSORIES:** Vegetable Slicer and Meat Chopper Attachment.

**WEIGHT:** Net – 100 lbs. Shipping – 140 lbs.

**WARRANTY:** Unit has a full one-year warranty on parts, labor and mileage against manufacturer's defects.

## DETAILS AND DIMENSIONS

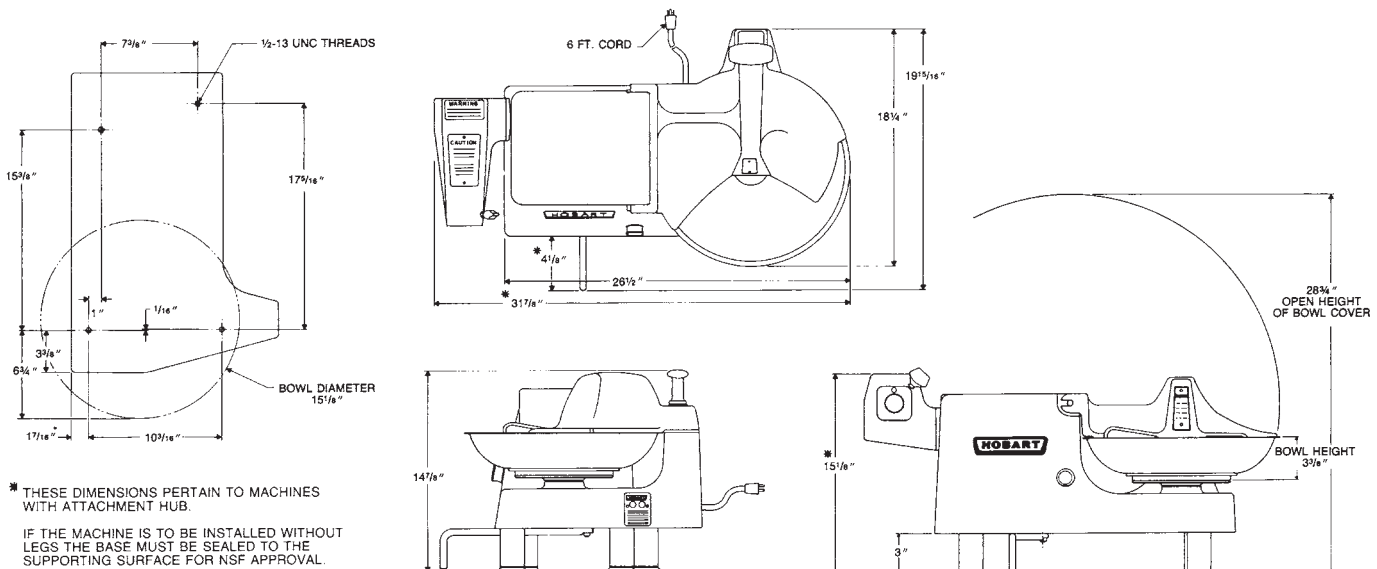

As continued product improvement is a policy of Hobart, specifications are subject to change without notice.

E-117147