

**ALTO-SHAAM®**

# Heated Display Cases

## Multi-Shelf Heated Display



ED2SYS-48/2S



ED2-48/2S



ED2SYS-72/2S



ED2-72/2S



ED2SYS-96/2S



ED2-96/2S

### Models:

**ED2-48/2S**

**ED2SYS-48/2S**

**ED2-72/2S**

**ED2SYS-72/2S**

**ED2-96/2S**

**ED2SYS-96/2S**

- **INSTALLATION**
- **OPERATION**
- **MAINTENANCE**

**HALO HEAT®**

**24•7**  
Your Service Hotline  
1-800-558-8744

W164 N9221 Water Street • P.O. Box 450 • Menomonee Falls, Wisconsin 53052-0450 USA  
PHONE: 262.251.3800 • 800.558.8744 USA/CANADA FAX: 262.251.7067 • 800.329.8744 U.S.A. ONLY  
[www.alto-shaam.com](http://www.alto-shaam.com)

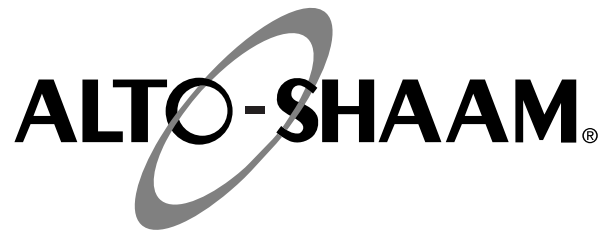

Delivery . . . . . 1  
Unpacking . . . . . 1  
Safety Procedures and Precautions . . . . . 2

**Installation**

Installation Requirements . . . . . 3  
Clearance Requirements . . . . . 3  
Leveling . . . . . 3  
Dimension Drawings . . . . . 4  
Electrical Connection . . . . . 5

**Operating Instructions**

User Safety Information . . . . . 6  
Capacity . . . . . 6  
Operating Procedures . . . . . 7  
General Holding Guidelines . . . . . 8

**Care and Cleaning**

Cleaning and Preventative Maintenance . . . . . 9  
Protecting Stainless Steel Surfaces . . . . . 9  
Cleaning Agents . . . . . 9  
Cleaning Materials . . . . . 9  
Equipment Care . . . . . 10  
Sanitation . . . . . 11

**Service**

Counter Top, Front View . . . . . 12-13  
Shelf Assembly . . . . . 14  
Counter Top, Back View . . . . . 15-16  
System, Front View . . . . . 17  
System, Back View . . . . . 18

**Wire Diagrams**

Always refer to the wire diagram(s) included with the unit for most current version.

**Warranty**

Transportation Damage and Claims . . . . . Back Cover  
Limited Warranty . . . . . Back Cover

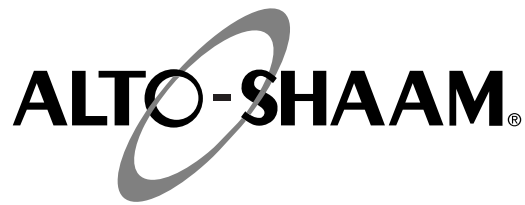

## DELIVERY

This Alto-Shaam appliance has been thoroughly tested and inspected to ensure only the highest quality unit is provided. Upon receipt, check for any possible shipping damage and report it at once to the delivering carrier. *See Transportation Damage and Claims section located in this manual.*

This appliance, complete with unattached items and accessories, may have been delivered in one or more packages. Check to ensure that all standard items and options have been received with each model as ordered.

Save all the information and instructions packed with the appliance. Complete and return the warranty card to the factory as soon as possible to ensure prompt service in the event of a warranty parts and labor claim.

This manual must be read and understood by all people using or installing the equipment model. Contact the Alto-Shaam Tech Team Service Department if you have any questions concerning installation, operation, or maintenance.

**NOTE:** All claims for warranty must include the full model number and serial number of the unit.

## UNPACKING

1. Carefully remove the appliance from the carton or crate.

**NOTE:** Do not discard the carton and other packaging material until you have inspected the unit for hidden damage and tested it for proper operation.

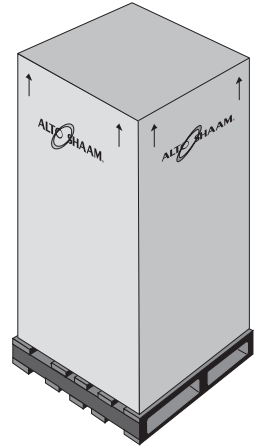

2. Read all instructions in this manual carefully before initiating the installation of this appliance.

**DO NOT DISCARD THIS MANUAL.**

This manual is considered to be part of the appliance and is to be provided to the owner or manager of the business or to the person responsible for training operators. *Additional manuals are available from the Alto-Shaam Tech Team Service Department.*

3. Remove all protective plastic film, packaging materials, and accessories from the appliance before connecting electrical power. Store any accessories in a convenient place for future use.

## SAFETY PROCEDURES AND PRECAUTIONS

Knowledge of proper procedures is essential to the safe operation of electrically and/or gas energized equipment. In accordance with generally accepted product safety labeling guidelines for potential hazards, the following signal words and symbols may be used throughout this manual.

### DANGER



Used to indicate the presence of a hazard that **WILL** cause severe personal injury, death, or substantial property damage if the warning included with this symbol is ignored.

### WARNING



Used to indicate the presence of a hazard that **CAN** cause personal injury, possible death, or major property damage if the warning included with this symbol is ignored.

### CAUTION



Used to indicate the presence of a hazard that can or will cause minor or moderate personal injury or property damage if the warning included with this symbol is ignored.

### CAUTION

Used to indicate the presence of a hazard that can or will cause minor personal injury, property damage, or a potential unsafe practice if the warning included with this symbol is ignored.

**NOTE:** Used to notify personnel of installation, operation, or maintenance information that is important but not hazard related.

1. This appliance is intended to hold foods for the purpose of human consumption. No other use for this appliance is authorized or recommended.
2. This appliance is intended for use in commercial establishments where all operators are familiar with the purpose, limitations, and associated hazards of this appliance. Operating instructions and warnings must be read and understood by all operators and users.
3. Any troubleshooting guides, component views, and parts lists included in this manual are for general reference only and are intended for use by qualified technical personnel.
4. This manual should be considered a permanent part of this appliance. This manual and all supplied instructions, diagrams, schematics, parts lists, notices, and labels must remain with the appliance if the item is sold or moved to another location.

### NOTE



For equipment delivered for use in any location regulated by the following directive:

**DO NOT DISPOSE OF ELECTRICAL OR ELECTRONIC EQUIPMENT WITH OTHER MUNICIPAL WASTE.**

# INSTALLATION

## DANGER



IMPROPER INSTALLATION, ALTERATION, ADJUSTMENT, SERVICE, OR MAINTENANCE COULD RESULT IN SEVERE INJURY, DEATH, OR CAUSE PROPERTY DAMAGE.

READ THE INSTALLATION, OPERATING AND MAINTENANCE INSTRUCTIONS THOROUGHLY BEFORE INSTALLING OR SERVICING THIS EQUIPMENT.

## CAUTION



METAL PARTS OF THIS EQUIPMENT BECOME EXTREMELY HOT WHEN IN OPERATION. TO AVOID BURNS, ALWAYS USE HAND PROTECTION WHEN OPERATING THIS APPLIANCE.

## CAUTION



TO PREVENT PERSONAL INJURY, USE CAUTION WHEN MOVING OR LEVELING THIS APPLIANCE.

## SITE INSTALLATION

In order to maintain established National Sanitation Foundation standards, all stationary floor models must be sealed to the floor with a R.T.V. or silastic meeting N.S.F. requirements or have 6" (152mm) unobstructed clearance beneath the unit.

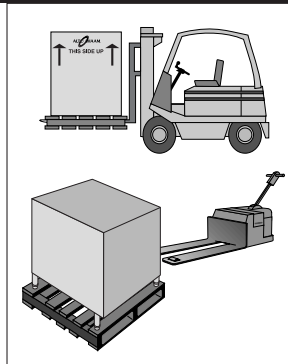

1. The appliance must be installed on a stable and level surface.
2. **DO NOT** install this appliance in any area where it may be affected by any adverse conditions such as steam, grease, dripping water, high temperatures, or any other severely adverse conditions.
3. **DO NOT** install a heated display case near a cold air source such as a freezer, air conditioning vents, or in any area where outside air fluctuation can affect performance.
4. This appliance must be kept free and clear of any obstructions blocking access for maintenance or service.
5. Care must be taken when moving this unit into place because of its glass components.

A number of adjustments are associated with initial installation and start-up. It is important that these adjustments be conducted by a qualified service technician. Installation and start-up adjustments are the responsibility of the dealer or user. These adjustments include but are not limited to thermostat calibration, door adjustment, leveling, electrical hook-up and installation of optional casters or legs.

## LEVELING

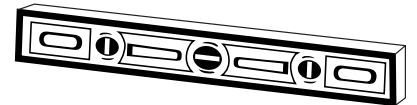

Level the appliance from side-to-side and front-to-back with the use of a spirit level.

We recommend checking the level periodically to make certain the floor has not shifted nor the appliance moved.

**NOTE:** Failure to properly level this appliance can cause improper function.

## MINIMUM CLEARANCE REQUIREMENTS

Counter and table units must be mounted on legs of a sufficient 4" (102mm) height to provide minimum unobstructed space beneath the unit. These legs are supplied with the unit. Warranty will become null and void if these directions are not followed.

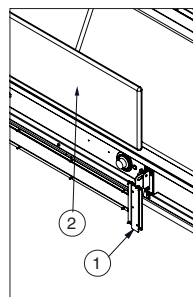

## Cutting board installation:

1. Place both brackets in the closed (down) position.
2. Slide cutting board back flanges down onto brackets.
3. Pivot installed board to a horizontal position and slide bracket down to lock in the open position. (NOT SHOWN)

# INSTALLATION

## SITE INSTALLATION

### ED2(SYS)/2S SERIES

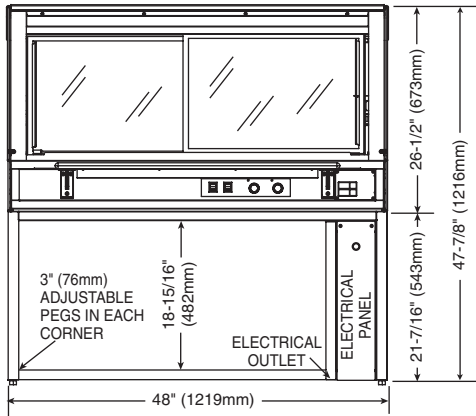

**ED2SYS-48/2S**

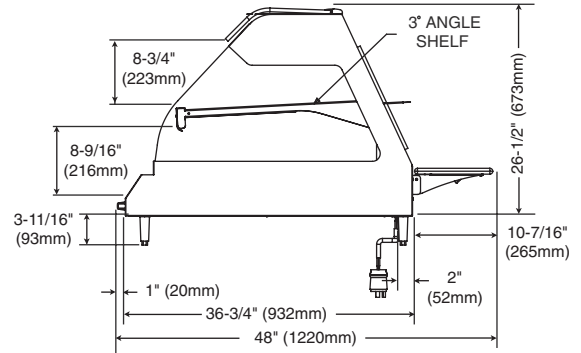

**ED2-2S PROFILE**

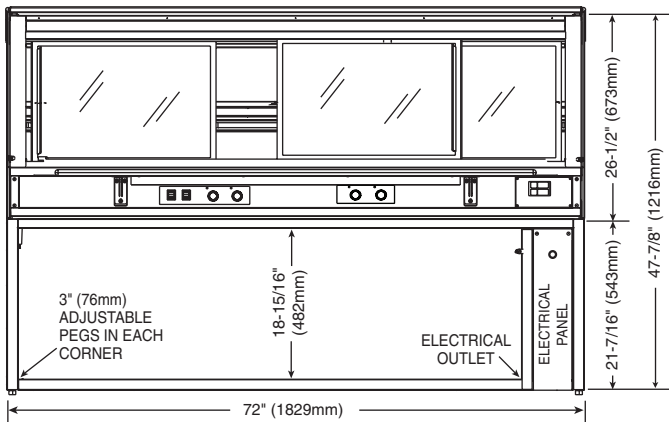

**ED2SYS-72/2S**

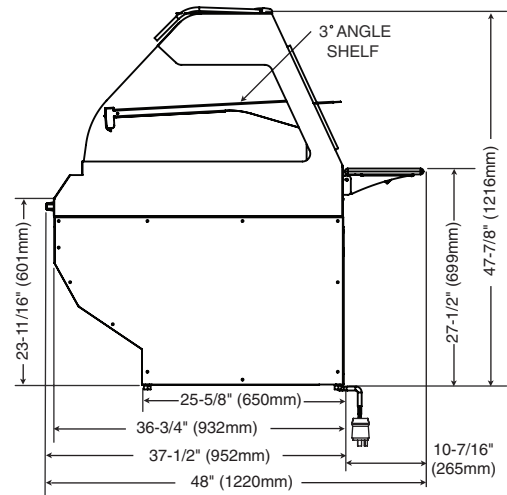

**ED2SYS-2S PROFILE**

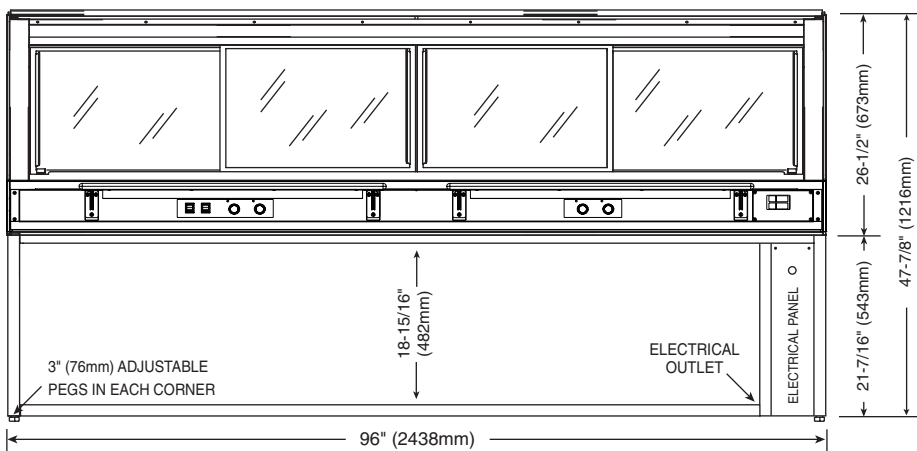

**ED2SYS-96/2S**

# INSTALLATION

## ELECTRICAL CONNECTION

The appliance must be installed by a qualified service technician. The oven must be properly grounded in accordance with the National Electrical Code and applicable local codes.

### DANGER

**To avoid electrical shock, this appliance MUST be adequately grounded in accordance with local electrical codes or, in the absence of local codes, with the current edition of the National Electrical Code ANSI/NFPA No. 70. In Canada, all electrical connections are to be made in accordance with CSA C22.1, Canadian Electrical Code Part 1 or local codes.**

Plug the unit into a properly grounded receptacle **ONLY**, positioning the unit so that the plug is easily accessible in case of an emergency. Arcing will occur when connecting or disconnecting the unit unless all controls are in the "OFF" position.

Proper receptacle or outlet configuration or permanent wiring for this unit must be installed by a licensed electrician in accordance with applicable local electrical codes.

<b>ELECTRICAL</b>					
<b>ED2-48/2S, ED2SYS-48/2S</b>					
VOLTAGE	PHASE	CYCLE/HZ	AMPS	kW	
208-240 (AGCY)	1	50/60	11.7	2.8	NEMA 6-20P 20A, 250V PLUG
at 208	1	50/60	10.0	2.1	
at 240	1	50/60	11.6	2.8	
<b>ED2-72/2S, ED2SYS-72/2S</b>					
VOLTAGE	PHASE	CYCLE/HZ	AMPS	kW	
208-240 (AGCY)	1	50/60	17.9	4.3	NEMA L6-30P 30A, 250V PLUG
at 208	1	50/60	17.1	3.6	
at 240	1	50/60	19.6	4.7	
<b>ED2-96/2S, ED2SYS-96/2S</b>					
VOLTAGE	PHASE	CYCLE/HZ	AMPS	kW	
208-240 (AGCY)	1	50/60	21.8	5.2	NEMA L6-30P 30A, 250V PLUG
at 208	1	50/60	20.2	4.2	
at 240	1	50/60	23.3	5.6	

Wire diagrams are located in the literature package that came with the unit.

### DANGER

**ELECTRICAL CONNECTIONS MUST BE MADE BY A QUALIFIED SERVICE TECHNICIAN IN ACCORDANCE WITH APPLICABLE ELECTRICAL CODES.**

### DANGER

**ENSURE POWER SOURCE MATCHES VOLTAGE STAMPED ON APPLIANCE NAMEPLATE.**

#### REGARDING INTERNATIONAL STANDARD UNITS:

If the unit is not equipped with flexible cord and plug, an all-pole country approved disconnection device which has a contact separation of at least 3mm in all poles must be incorporated in the fixed wiring for disconnection. When using a cord without a plug, the green/yellow conductor shall be connected to the terminal which is marked with the ground symbol. If a plug is used, the socket outlet must be easily accessible. If the power cord needs replacement, use a similar one obtained from the distributor.

**For CE approved units:** To prevent an electrical shock hazard between the appliance and other appliances or metal parts in close vicinity, an equalization-bonding stud is provided. An equalization bonding lead must be connected to this stud and the other appliances / metal parts to provide sufficient protection against potential difference. The terminal is marked with the following symbol.



#### Hard wired models:

Hard wired models must be equipped with a country certified external allpole disconnection switch with sufficient contact separation.

If a power cord is used for the connection of the product an oil resistant cord like H05RN or H07RN or equivalent must be used.

**NOTE:** CE approved appliances must be connected to an electrical circuit that is protected by an external GFCI outlet.

# OPERATING INSTRUCTIONS

## USER SAFETY INFORMATION

This appliance is intended for use in commercial establishments where all operators are familiar with the purpose, limitations, and associated hazards of this appliance. Operating instructions and warnings must be read and understood by all operators and users.

### BEFORE INITIAL USE:

Before operating, clean with a damp cloth and mild soap solution. Glass cleaner can be used on the glass.

### SPECIAL INSTRUCTIONS:

1. Do not allow liquids or food to come in direct contact with the glass shelves.
2. Use hand protection when handling hot items.
3. Be certain only hot foods in appropriate heat tested containers are used.
4. It is recommended that plastic or paper containers be used. Pans or dishes will scratch the glass.
5. Be careful not to overheat as this may cause some containers to melt.
6. Do not stack containers.

### HEATING CHARACTERISTICS

The heated upper glass surface provides even heat transfer to hot food in heat tested containers that are held in direct contact with the glass top.

## DANGER



AT NO TIME SHOULD THE INTERIOR OR EXTERIOR BE STEAM CLEANED, HOSED DOWN, OR FLOODED WITH WATER OR LIQUID SOLUTION OF ANY KIND. DO NOT USE WATER JET TO CLEAN.



**SEVERE DAMAGE OR ELECTRICAL HAZARD COULD RESULT.**

**WARRANTY BECOMES VOID IF APPLIANCE IS FLOODED**



## DANGER



**DISCONNECT UNIT FROM POWER SOURCE BEFORE CLEANING OR SERVICING.**

## CAUTION



**METAL PARTS OF THIS EQUIPMENT BECOME EXTREMELY HOT WHEN IN OPERATION. TO AVOID BURNS, ALWAYS USE HAND PROTECTION WHEN OPERATING THIS APPLIANCE.**

### PRODUCT CAPACITY

**ED2-48/2S; ED2SYS-48/2S**

#### TOP SHELF

Twelve (12) chicken boats with dome cover

#### BOTTOM SHELF

Fifteen (15) chicken boats with dome cover

**ED2-72/2S; ED2SYS-72/2S**

#### TOP SHELF

Eighteen (18) chicken boats with dome cover

#### BOTTOM SHELF

Twenty-one (21) chicken boats with dome cover

**ED2-96/2S; ED2SYS-96/2S**

#### TOP SHELF

Twenty-four (24) chicken boats with dome cover

#### BOTTOM SHELF

Thirty (30) chicken boats with dome cover

**To avoid personal injury and damage to the unit, treat glass with care.**

**Remember — glass can shatter.**



# OPERATING INSTRUCTIONS

## OPERATING PROCEDURES

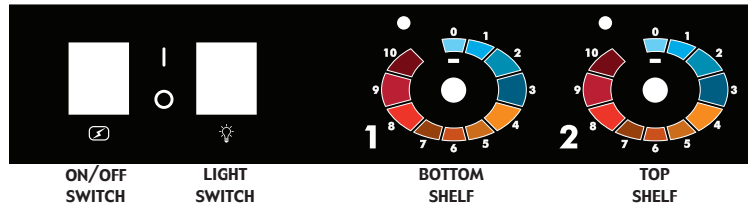

- 1. Check that the unit is connected to the appropriate power source.**
- 2. Turn thermostat(s) to a predetermined number and preheat for 30 minutes.**

Each shelf has its own thermostat control numbering from 0 to 10. When the thermostat is turned clockwise to the determined number, the indicator light will illuminate and will remain lit as long as the shelf is calling for heat.

The indicator light will go OUT when the temperature on the glass top reaches the set number determined by the operator. It will then cycle "on/off" at this holding point.

The shelves will hold a steady even heat as assigned. The user must determine what set point can be used regarding each food item held on its corresponding shelf. It is recommended that a similar food product be placed on each shelf.

The proper temperature range for the food being held will depend on the food type, the packaging, and the quantity of product. When holding food for prolonged periods, it is advisable to periodically check the internal temperature of each item to assure maintenance of the proper temperature range.

- 3. Load prepackaged hot foods into the display case.**

Before loading food into the unit, use a pocket-type meat thermometer to make certain all products have reached an internal temperature of 160°F (71°C) or higher. If any food product is not at proper serving temperature, use a Halo Heat cooking and holding oven or Combitherm Oven to bring the product within the correct temperature range.

- 4. Occasionally rotate foods as needed.**

Wipe spills immediately to assure maximum eye appeal and minimized-of-the-day cleanup.

- 5. Keep display case doors closed after serving.**

# OPERATING INSTRUCTIONS

## GENERAL HOLDING GUIDELINES

Chefs, cooks and other specialized food service personnel employ varied methods of cooking. Proper holding temperatures for a specific food product must be based on the moisture content of the product, product density, volume, and proper serving temperatures. Safe holding temperatures must also be correlated with palatability in determining the length of holding time for a specific product.

Halo Heat maintains the maximum amount of product moisture content without the addition of water, water vapor, or steam. Maintaining maximum natural product moisture preserves the natural flavor of the product and provides a more genuine taste. In addition to product moisture retention, the gentle properties of Halo Heat maintain a consistent temperature throughout the cabinet without the necessity of a heat distribution fan, thereby preventing further moisture loss due to evaporation or dehydration.

When product is removed from a high temperature cooking environment for immediate transfer into equipment with the lower temperature required for hot food holding, condensation can form on the outside of the product and on the inside of plastic containers used in self-service applications. Allowing the product to release the initial steam and heat produced by high temperature cooking can alleviate this condition. To preserve the safety and quality of freshly cooked foods however, a maximum of 1 to 2 minutes must be the only time period allowed for the initial heat to be released from the product.

The unit is equipped with a thermostat indicating a range of between 1 and 10. Use a metal-stemmed indicating thermometer to measure the internal temperature of the product(s) being held. Adjust the thermostat setting to achieve the best overall setting based on internal product temperature.

HOLDING TEMPERATURE RANGE		
MEAT	FAHRENHEIT	CELSIUS
BEEF ROAST — Rare	130°F	54°C
BEEF ROAST — Med/Well Done	155°F	68°C
BEEF BRISKET	160° — 175°F	71° — 79°C
CORN BEEF	160° — 175°F	71° — 79°C
PASTRAMI	160° — 175°F	71° — 79°C
PRIME RIB — Rare	130°F	54°C
STEAKS — Broiled/Fried	140° — 160°F	60° — 71°C
RIBS — Beef or Pork	160°F	71°C
VEAL	160° — 175°F	71° — 79°C
HAM	160° — 175°F	71° — 79°C
PORK	160° — 175°F	71° — 79°C
LAMB	160° — 175°F	71° — 79°C
POULTRY		
CHICKEN — Fried/Baked	160° — 175°F	71° — 79°C
DUCK	160° — 175°F	71° — 79°C
TURKEY	160° — 175°F	71° — 79°C
GENERAL	160° — 175°F	71° — 79°C
FISH/SEAFOOD		
FISH — Baked/Fried	160° — 175°F	71° — 79°C
LOBSTER	160° — 175°F	71° — 79°C
SHRIMP — Fried	160° — 175°F	71° — 79°C
BAKED GOODS		
BREADS/ROLLS	120° — 140°F	49° — 60°C
MISCELLANEOUS		
CASSEROLES	160° — 175°F	71° — 79°C
DOUGH — Proofing	80° — 100°F	27° — 38°C
EGGS — Fried	150° — 160°F	66° — 71°C
FROZEN ENTREES	160° — 175°F	71° — 79°C
HORS D'OEUVRES	160° — 180°F	71° — 82°C
PASTA	160° — 180°F	71° — 82°C
PIZZA	160° — 180°F	71° — 82°C
POTATOES	180°F	82°C
PLATED MEALS	140° — 165°F	60° — 74°C
SAUCES	140° — 200°F	60° — 93°C
SOUP	140° — 200°F	60° — 93°C
VEGETABLES	160° — 175°F	71° — 79°C
<b>THE HOLDING TEMPERATURES LISTED ARE SUGGESTED GUIDELINES ONLY. ALL FOOD HOLDING SHOULD BE BASED ON INTERNAL PRODUCT TEMPERATURES. ALWAYS FOLLOW LOCAL HEALTH (HYGIENE) REGULATIONS FOR ALL INTERNAL TEMPERATURE REQUIREMENTS.</b>		

# CARE AND CLEANING

## CLEANING AND PREVENTIVE MAINTENANCE

### PROTECTING STAINLESS STEEL SURFACES



It is important to guard against corrosion in the care of stainless steel surfaces. Harsh, corrosive, or inappropriate chemicals can completely destroy the protective surface layer of stainless steel. Abrasive pads, steel wool, or metal implements will abrade surfaces causing damage to this protective coating and will eventually result in areas of corrosion. Even water, particularly hard water that contains high to moderate concentrations of chloride, will cause oxidation and pitting that result in rust and corrosion. In addition, many acidic foods spilled and left to remain on metal surfaces are contributing factors that will corrode surfaces.





Proper cleaning agents, materials, and methods are vital to maintaining the appearance and life of this appliance. Spilled foods should be removed and the area wiped as soon as possible but at the very least, a minimum of once a day. Always thoroughly rinse surfaces after using a cleaning agent and wipe standing water as quickly as possible after rinsing.

### CLEANING AGENTS

Use non-abrasive cleaning products designed for use on stainless steel surfaces. Cleaning agents must be chloride-free compounds and must not contain quaternary salts. Never use hydrochloric acid (muriatic acid) on stainless steel surfaces. Always use the proper cleaning agent at the manufacturer's recommended strength. Contact your local cleaning supplier for product recommendations.

### CLEANING MATERIALS

The cleaning function can usually be accomplished with the proper cleaning agent and a soft, clean cloth. When more aggressive methods must be employed, use a non-abrasive scouring pad on difficult areas and make certain to scrub with the visible grain of surface metal to avoid surface scratches. Never use wire brushes, metal scouring pads, or scrapers to remove food residue.

 <b>CAUTION</b>	
	<b>TO PROTECT STAINLESS STEEL SURFACES, COMPLETELY AVOID THE USE OF ABRASIVE CLEANING COMPOUNDS, CHLORIDE BASED CLEANERS, OR CLEANERS CONTAINING QUATERNARY SALTS. NEVER USE HYDROCHLORIC ACID (MURIATIC ACID) ON STAINLESS STEEL. NEVER USE WIRE BRUSHES, METAL SCOURING PADS OR SCRAPERS.</b>
	
	

# CARE AND CLEANING

## EQUIPMENT CARE

Under normal circumstances, this appliance should provide you with long and trouble free service. There is no preventative maintenance required, however, the following Equipment Care Guide will maximize the potential life and trouble free operation of this appliance. The cleanliness and appearance of this equipment will contribute considerably to operating efficiency and savory, appetizing food. Good equipment that is kept clean works better and lasts longer.



## CLEAN THE UNIT THOROUGHLY AFTER EACH USE

1. Turn lights and adjustable thermostat(s) to the "OFF" position. Disconnect unit from power source, and let cool.
2. Remove, cover or wrap, and store food product under refrigeration.
3. *Do not clean the glass when hot.* The glass should be cleaned regularly with fresh warm water, a mild detergent, and a clean, non-abrasive cloth. Glass cleaner can be used.
4. Clean interior with a damp cloth or sponge and any good commercial detergent at the recommended strength.
5. The aluminum plate shelves have a clear coat anodized surface that must be cleaned with a multi-purpose cleaner to avoid distortion and deterioration of the surface. First test the cleaner on a small portion of the plate in an inconspicuous corner of the shelf before proceeding.
6. Spray heavily soiled areas with a water soluble degreaser and let stand for 10 minutes, then remove soil with a plastic scouring pad.

**NOTE:** Avoid the use of abrasive cleaning compounds, chloride based cleaners, or cleaners containing quaternary salts. Never use hydrochloric acid (muriatic acid) on stainless steel.



7. Clean control panel, vents, handles, and gaskets thoroughly since these areas harbor food debris.
8. Rinse surfaces by wiping with sponge and clean warm water.

9. Remove excess water with sponge and wipe dry with a clean cloth or air dry.
10. Interior can be wiped with a sanitizing solution after cleaning and rinsing. This solution must be approved for use on food contact surfaces.
11. To help maintain the protective film coating on any polished stainless steel, clean the exterior of the cabinet with a cleaner recommended for stainless steel surfaces. Spray the cleaning agent on a clean cloth and wipe with the grain of the stainless steel.

Always follow appropriate state or local health (hygiene) regulations regarding all applicable cleaning and sanitation requirements for foodservice equipment.

## DANGER



AT NO TIME SHOULD THE INTERIOR OR EXTERIOR BE STEAM CLEANED, HOSED DOWN, OR FLOODED WITH WATER OR LIQUID SOLUTION OF ANY KIND. DO NOT USE WATER JET TO CLEAN.



**SEVERE DAMAGE OR ELECTRICAL HAZARD COULD RESULT.**

**WARRANTY BECOMES VOID IF APPLIANCE IS FLOODED**



## DANGER



**DISCONNECT UNIT FROM POWER SOURCE BEFORE CLEANING OR SERVICING.**

## CAUTION



The performance of this unit has been optimized using the factory provided bulbs. These bulbs should be replaced with an exact replacement or with a factory recommended replacement. These bulbs have been treated to resist breakage and must be replaced with similarly treated bulbs in order to maintain compliance with NSF standards. **DO NOT** over-tighten bulbs in their receptacles as this can cause damage to the bulb filament.

Food flavor and aroma are usually so closely related that it is difficult, if not impossible, to separate them. There is also an important, inseparable relationship between cleanliness and food flavor. Cleanliness, top operating efficiency, and appearance of equipment contribute considerably to savory, appetizing foods. Good equipment that is kept clean, works better and lasts longer.

Most food imparts its own particular aroma and many foods also absorb existing odors. Unfortunately, during this absorption there is no distinction between GOOD and BAD odors. The majority of objectionable flavors and odors troubling food service operations are caused by bacteria growth. Sourness, rancidity, mustiness, stale or other OFF flavors are usually the result of germ activity.

The easiest way to insure full, natural food flavor is through comprehensive cleanliness. This means good control of both visible soil (dirt) and invisible soil (germs). A thorough approach to sanitation will provide essential cleanliness. It will assure an attractive appearance of equipment, along with maximum efficiency and utility. More importantly, a good sanitation program provides one of the key elements in the prevention of food-borne illnesses.

A controlled holding environment for prepared foods is just one of the important factors involved in the prevention of food-borne illnesses. Temperature monitoring and control during receiving, storage, preparation, and the service of foods are of equal importance.

The most accurate method of measuring safe temperatures of both hot and cold foods is by internal product temperature. A quality thermometer is an effective tool for this purpose, and should be routinely used on all products that require holding at a specific temperature.

A comprehensive sanitation program should focus on the training of staff in basic sanitation procedures. This includes personal hygiene, proper handling of raw foods, cooking to a safe internal product temperature, and the routine monitoring of internal temperatures from receiving through service.

Most food-borne illnesses can be prevented through proper temperature control and a comprehensive program of sanitation. Both these factors are important to build quality service as the foundation of customer satisfaction. Safe food handling practices to prevent food-borne illness is of critical importance to the health and safety of your customers.

HACCP, an acronym for Hazard Analysis (at) Critical Control Points, is a quality control program of operating procedures to assure food integrity, quality, and safety. Taking steps necessary to augment food safety practices is both cost effective and relatively simple. While HACCP guidelines go far beyond the scope of this manual, additional information is available by contacting:

**CENTER FOR FOOD SAFETY AND APPLIED  
NUTRITION FOOD AND DRUG ADMINISTRATION  
1-888-SAFEFOOD**

<b>INTERNAL FOOD PRODUCT TEMPERATURES</b>		
<b>HOT FOODS</b>		
<b>DANGER ZONE</b>	<b>40° TO 140°F</b>	<b>(4° TO 60°C)</b>
<b>CRITICAL ZONE</b>	<b>70° TO 120°F</b>	<b>(21° TO 49°C)</b>
<b>SAFE ZONE</b>	<b>140° TO 165°F</b>	<b>(60° TO 74°C)</b>
<b>COLD FOODS</b>		
<b>DANGER ZONE</b>	<b>ABOVE 40°F</b>	<b>(ABOVE 4°C)</b>
<b>SAFE ZONE</b>	<b>36° TO 40°F</b>	<b>(2° TO 4°C)</b>
<b>FROZEN FOODS</b>		
<b>DANGER ZONE</b>	<b>ABOVE 32°F</b>	<b>(ABOVE 0°C)</b>
<b>CRITICAL ZONE</b>	<b>0° TO 32°F</b>	<b>(-18° TO 0°C)</b>
<b>SAFE ZONE</b>	<b>0°F or below</b>	<b>(-18°C or below)</b>

# SERVICE

## COUNTER TOP (ED2-96/2S SHOWN)

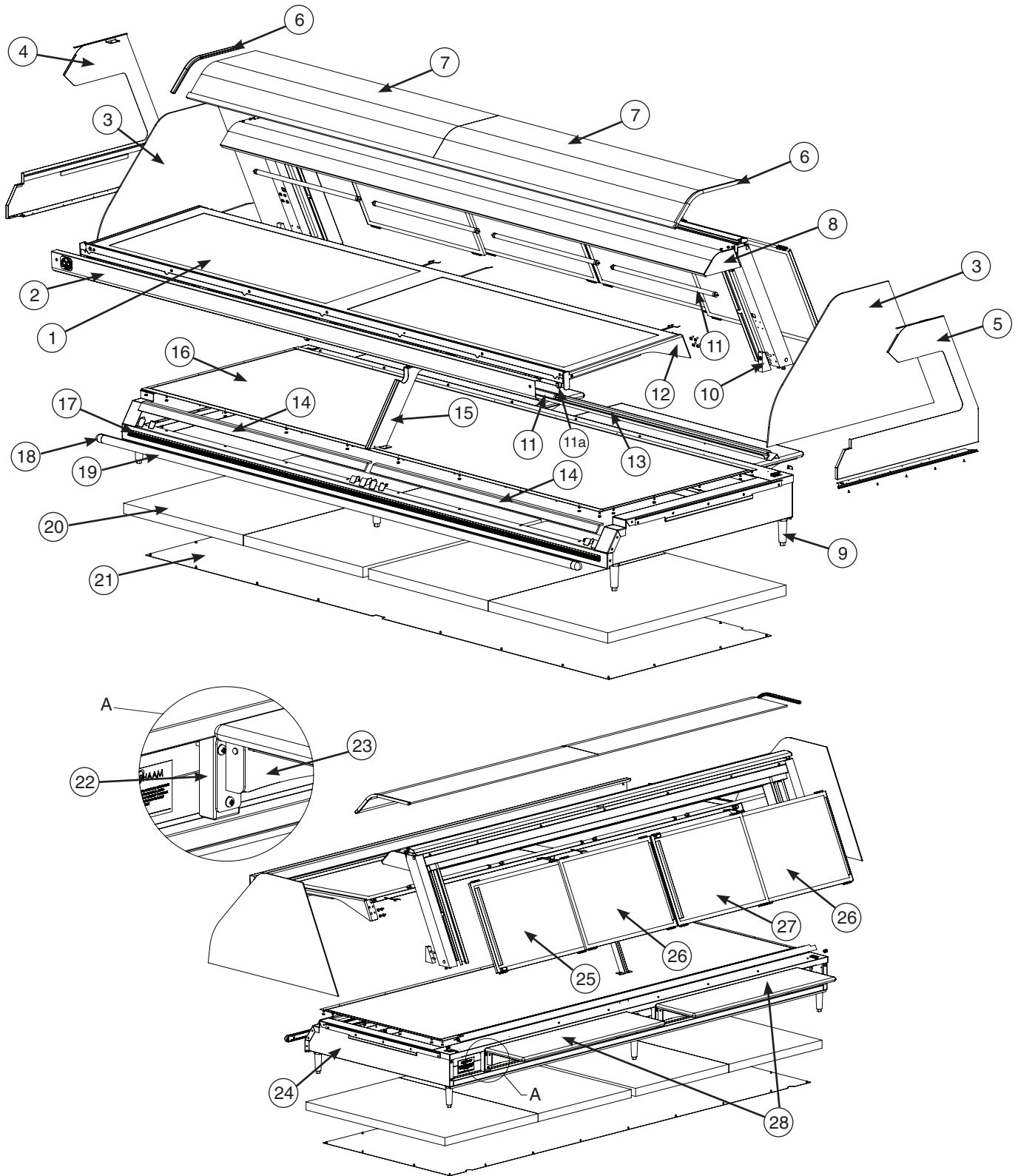

Part numbers and drawings are subject to change without notice.

## COUNTER TOP (ED2-96/2S SHOWN)

MODEL >		ED2(SYS)-48/2S*		ED2(SYS)-72/2S*		ED2(SYS)-96/2S	
ITEM	DESCRIPTION	PART NO.	QTY	PART NO.	QTY	PART NO.	QTY
1	SHELF ASSEMBLY (SEE PAGE 14)	5004203	1	5004097	1	5004238	1
2	SHELF FRONT COVER	1005155	1	1005053	1	1005194	1
3	GLASS, END	GL-25762	2	GL-25762	2	GL-25762	2
4	GLASS COVER, LH (BLK)	5001726	1	5001726	1	5001726	1
	GLASS COVER, LH (S/S)	5005470	2	5005470	2	5005470	2
5	GLASS COVER, RH (BLK)	5001725	1	5001725	1	5001725	1
	GLASS COVER, RH (S/S)	5005469	1	5005469	1	5005469	1
6	GASKET	GS-22547	2	GS-22547	2	GS-22547	2
7	GLASS, CURVED	GL-26028	1	GL-26773	1	GL-26028	2
8	CANOPY ASSEMBLY	5001752	1	5003763	1	5004232	1
9	LEG, 4" (102mm)	LG-2044	4	LG-2044	4	LG-2044	6
10	UPRIGHT WEDGE	BK-26025	2	BK-26025	2	BK-26025	2
11	LAMPS, FLORESCENTS, SOFT WHITE, T5, 13W	LP-33822	4	LP-33822	6	LP-33822	8
11a	RECEPTACLE, FLORESCENT, LIGHT	RP-34160	4	RP-34160	6	RP-34160	8
12	SHELF SUPPORT BRACKET, RH	1005054	1	1005054	1	1005054	1
	SHELF SUPPORT BRACKET, LH	1005055	1	1005055	1	1005055*	1
13	BOTTOM DOOR TRACK	TK-26751	1	TK-26859	1	TK-27861	1
14	GUARD, LEXAN	GD-27170	1	GD-27171	2	GD-27172	2
15	SHELF SUPPORT WELD	—	—	5004592	1	5004592	1
16	ALUMINUM HEAT PLATE ASSEMBLY	5001730	1	5003762	1	5004215	1
17	BUMPER TRACK	1011790	1	1011792	1	1011796	1
18	BUMPER, RAIL, END CAP	BM-29354	2	BM-29354	2	BM-29354	2
19	BUMPER, 4ft (1219mm)	1011791	1	—	—	—	—
	BUMPER, 6ft (1829mm)	—	—	1011793	1	—	—
	BUMPER, 8ft (2438mm)	—	—	—	—	1011797	1
20	INSULATION, 6ft <sup>2</sup> (557,418mm <sup>2</sup> )	IN-22364	2	IN-22364	4	IN-22364	4
21	PANEL, COVER, BOTTOM	1002499	1	1004183	1	1005183	1
22	BRACKET, CUTTING BOARD	11283	2	11283	2	11283	4
23	CUTTING BOARD BRACKET	BT-2342	2	BT-2342	2	BT-2342	4
24	WELL BASE ASSEMBLY (BLK)	5001715	1	5003761	1	5004214	1
	WELL BASE ASSEMBLY (S/S)	5005551	1	5005781	1	5005980	1
25	DOOR, GLASS, LH	DR-25422	1	DR-25422	1	DR-25422	1
26	DOOR, GLASS, MIDDLE	DR-25423	1	DR-25423	1	DR-25423	2
27	DOOR, GLASS, RH	—	—	DR-25424	1	DR-25424	1
28	CUTTING BOARD ASSEMBLY, 4ft (1219mm)	4016	1	—	—	4016	2
	CUTTING BOARD ASSEMBLY, 6ft (1829mm)	—	—	4017	1	—	—

Part numbers and drawings are subject to change without notice.

# SERVICE

## SHELF ASSEMBLY (ED2(SYS)-96/2S - 5004238 - SHOWN)

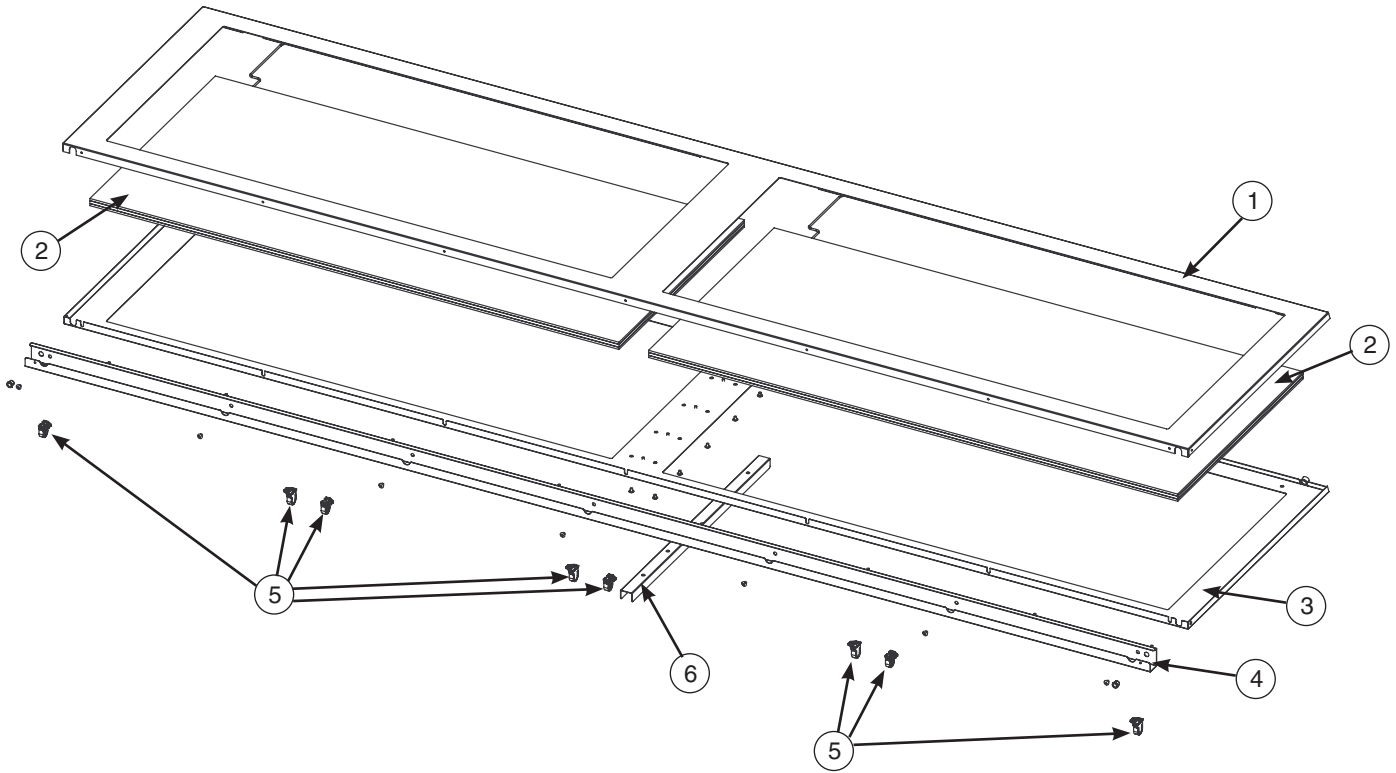

		MODEL >		ED2(SYS)-48/2S		ED2(SYS)-72/2S		ED2(SYS)-96/2S	
ITEM	DESCRIPTION	PART NO.	QTY	PART NO.	QTY	PART NO.	QTY	PART NO.	QTY
—	SHELF ASSEMBLY (COMPLETE)	5004203	1	5004097	1	5004238	1		
1	TOP SHELF PANEL SPOT	5004204	1	5004096	1	5004239	1		
2	HEATED GLASS SHELF, 208-240V	GL-25860	1	GL-26512	2	GL-25860	2		
3	SHELF BOTTOM PANEL	1005149	1	1005051	1	1005196	1		
4	SHELF LIGHT ATTACHMENT	1005150	1	1005052	1	1005197	1		
5	RECEPTACLE, FLORESCENT	RP-34160	4	RP-34160	6	RP-34160	8		
6	SHELF ATTACHMENT CHANNEL	—	—	1005744	1	1005744	1		

Part numbers and drawings are subject to change without notice.



## ELECTRICAL VIEW (ED2(SYS)-96/2S SHOWN)

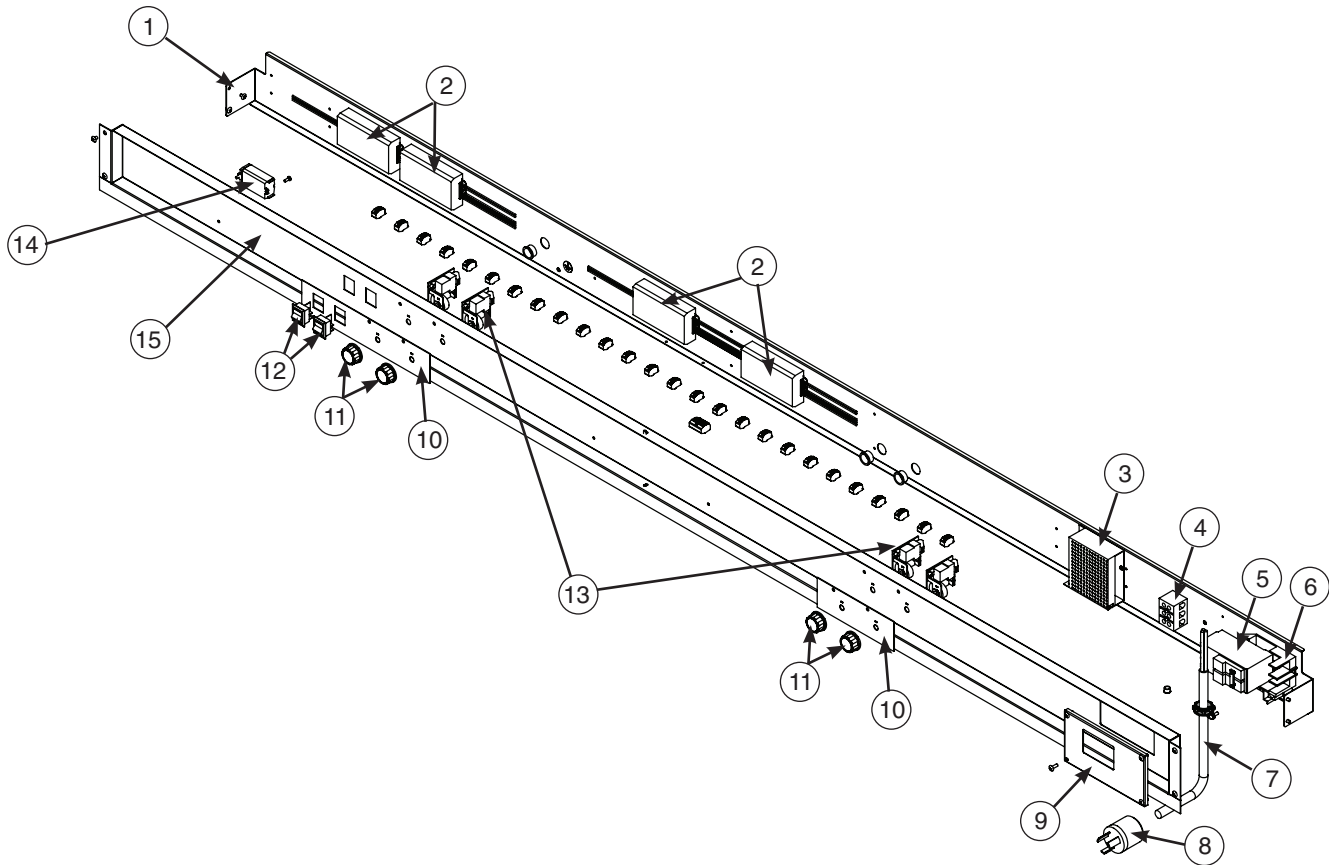

		MODEL >		ED2(SYS)-48/2S		ED2(SYS)-72/2S		ED2(SYS)-96/2S	
ITEM	DESCRIPTION	PART NO.	QTY	PART NO.	QTY	PART NO.	QTY	PART NO.	QTY
1	ELECTRONIC COMPONENT ASSEMBLY	5003229	1	5003778	1	5004242	1		
2	BALLAST, DUAL LIGHT	LP-34024	2	LP-34024	3	LP-34024	4		
3	BOARD, POWER SUPPLY, 12V DV, SWITCH	BA-33554	1	BA-33554	1	BA-33554	1		
4	T-BLOCK	BK-3019	1	BK-3019	1	BK-3019	1		
5	GFCI, 50AMP, 120/240V	CI-34105	1	CI-34105	1	CI-34105	1		
6	GFCI BASE, 50AMP, 120/240V	CI-34104	1	CI-34104	1	CI-34104	1		
7	CORD, 9ft (2743mm)	CD-3607	1	CD-3304	1	CD-3304	1		
8	PLUG, NEMA 6-20P, 20A, 250V	PG-33876	1	—	—	—	—		
	PLUG, NEMA L6-30P, 30A, 250V	—	—	PG-34207	1	PG-34207	1		
9	GFCI COVER PANEL	1005125	1	1005068	1	1005068	1		
10	PANEL OVERLAY	PE-26096	1	PE-26096	2	PE-26096	2		
11	KNOB, PLASTIC, BLACK	KN-26290	2	KN-26290	4	KN-26290	4		
12	SWITCH, ROCKER, HIGH-INRUSH	SW-3887	2	SW-3887	2	SW-3887	2		
13	CONTROL, 8 AMP, DIGITAL	BA-34294	2	—	—	—	—		
	CONTROL, 15 AMP, DIGITAL	—	—	BA-34295	4	BA-34295	4		
14	MODULAR BLOCK, 5 PIECE	—	—	BK-25567	1	BK-25567	1		
15	COVER PANEL SPOT WELD	5001739	1	5003780	1	5004233	1		

Part numbers and drawings are subject to change without notice.

# SERVICE

## BASE (ED2SYS-96/2S SHOWN)

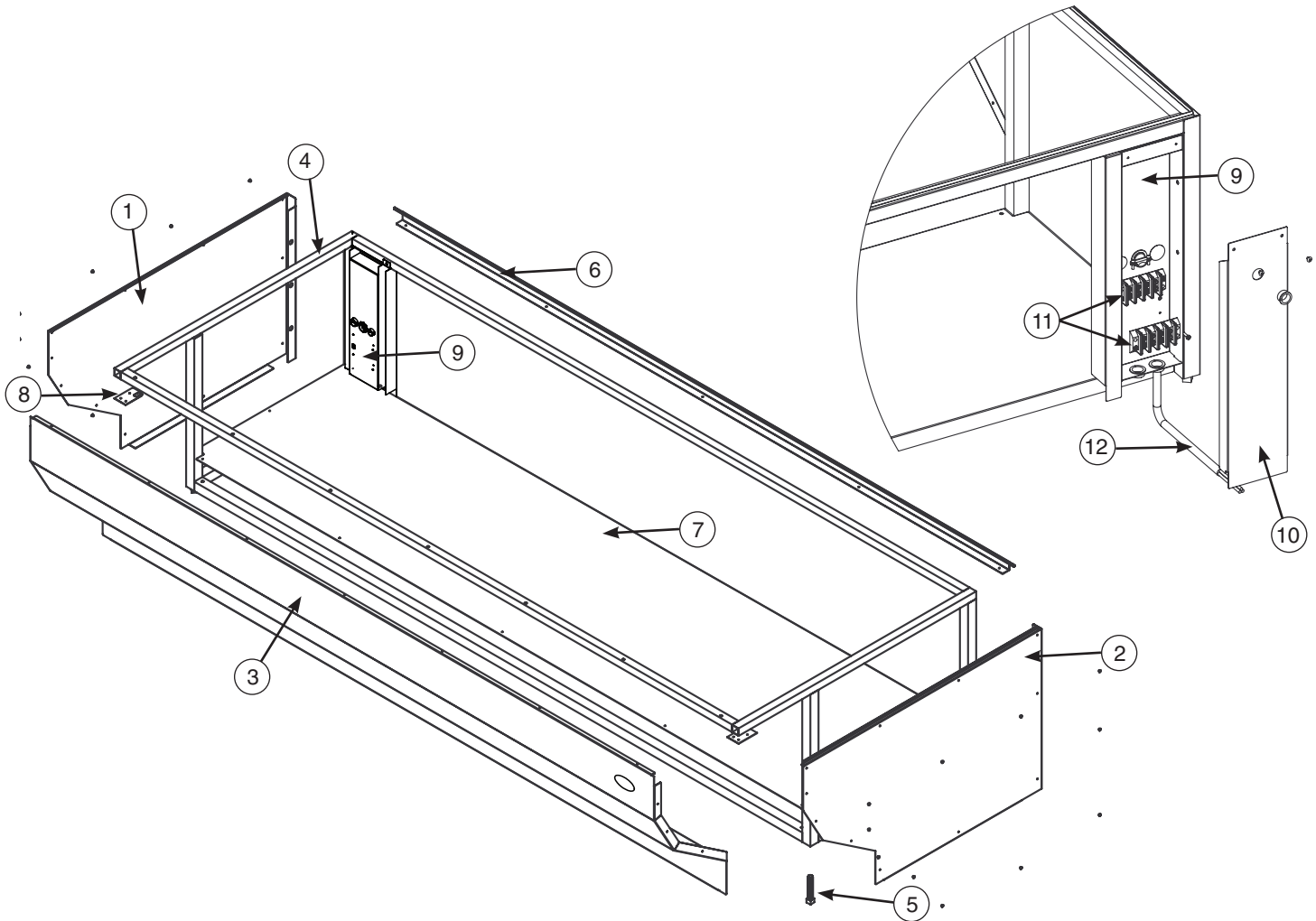

		MODEL >		ED2(SYS)-48/2S		ED2(SYS)-72/2S		ED2(SYS)-96/2S	
ITEM	DESCRIPTION	PART NO.	QTY	PART NO.	QTY	PART NO.	QTY		
1	BASE END PANEL, LH (BLK)	1002481	1	1002481	1	1002481	1		
	BASE END PANEL, LH (S/S)	1006776	1	1006776	1	1006776	1		
2	BASE END PANEL, RH (BLK)	1002480	1	1002480	1	1002480	1		
	BASE END PANEL, RH (S/S)	1006775	1	1006775	1	1006775	1		
3	BASE FRONT PANEL (BLK)	1002478	1	1004822	1	1005157	1		
	BASE FRONT PANEL (S/S)	1006774	1	1007021	1	1005158	1		
4	FRAME	FR-26626	1	FR-26775	1	FR-26865	1		
5	SCREW, SQUARE HEAD, 5/8 X 11	SC-2242	4	SC-2242	4	SC-2242	4		
6	TRIM, BACK	1006781	1	1004823	1	1005159	1		
7	BASE BOTTOM PANEL	1002479	1	1004821	1	1005158	1		
8	BASE FEET HOLDER PLATES	1002482	2	1002482	2	1002482	2		
9	ELECTRONIC HOUSING PANEL SPOT	5003530	1	5003530	1	5003530	1		
10	BACK ACCESS PANEL COVER	1002485	1	1002485	1	1002485	1		
11	TERMINAL BLOCK	BK-3023	2	BK-3023	2	BK-3023	2		
12	CORD, 9ft (2743mm)	CD-3607	1	CD-3304	1	CD-3304	1		

Part numbers and drawings are subject to change without notice.

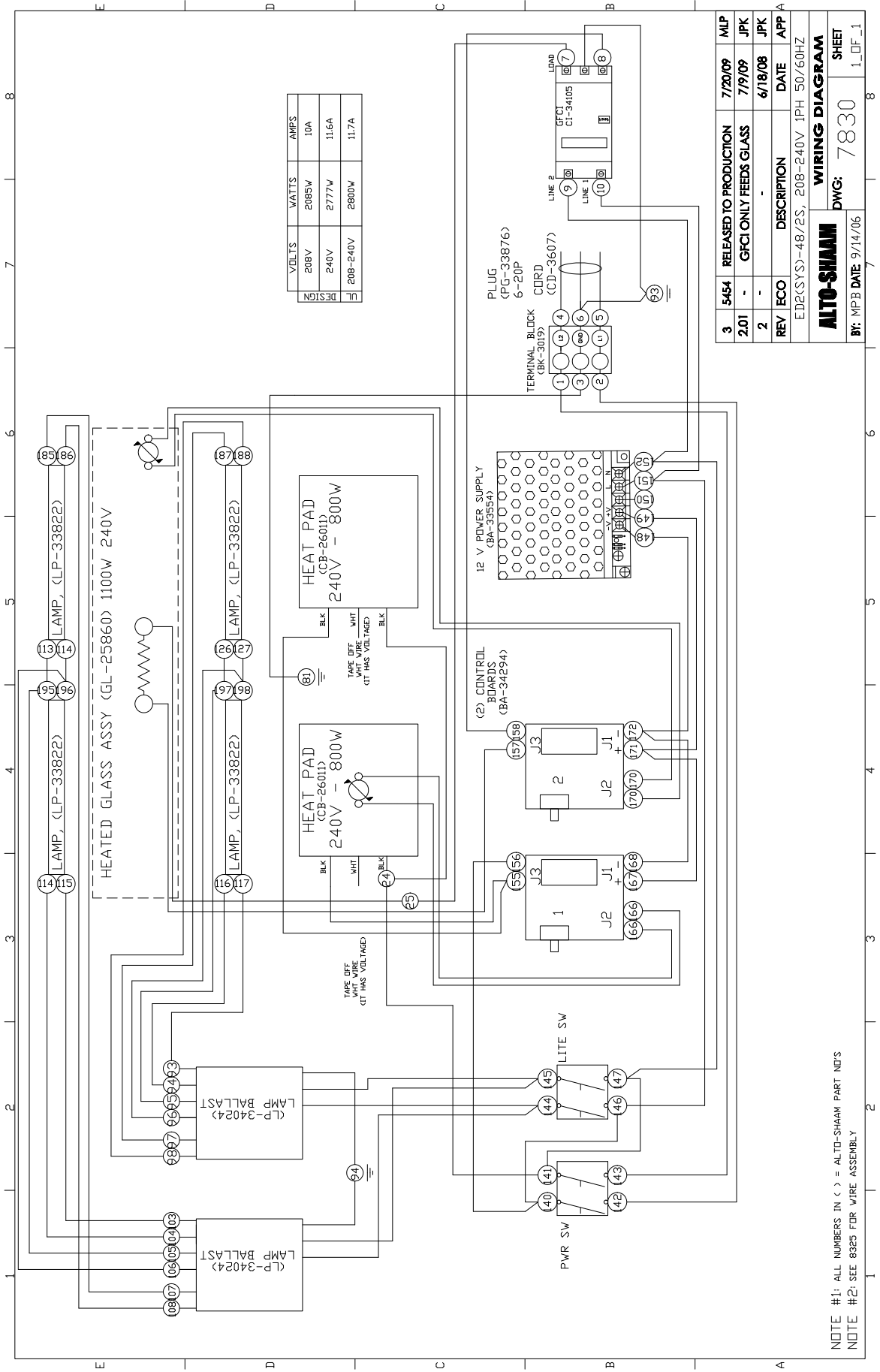

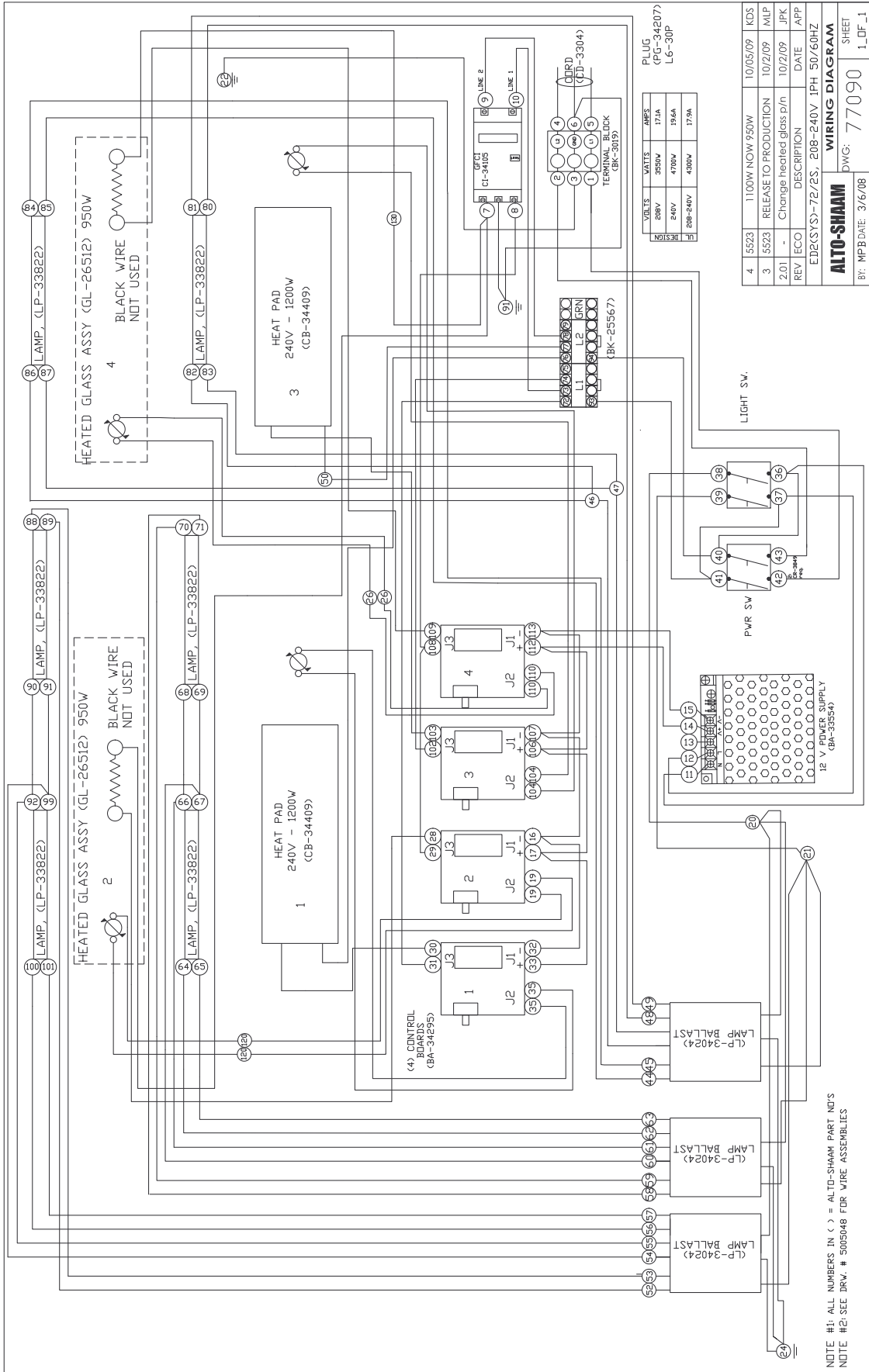

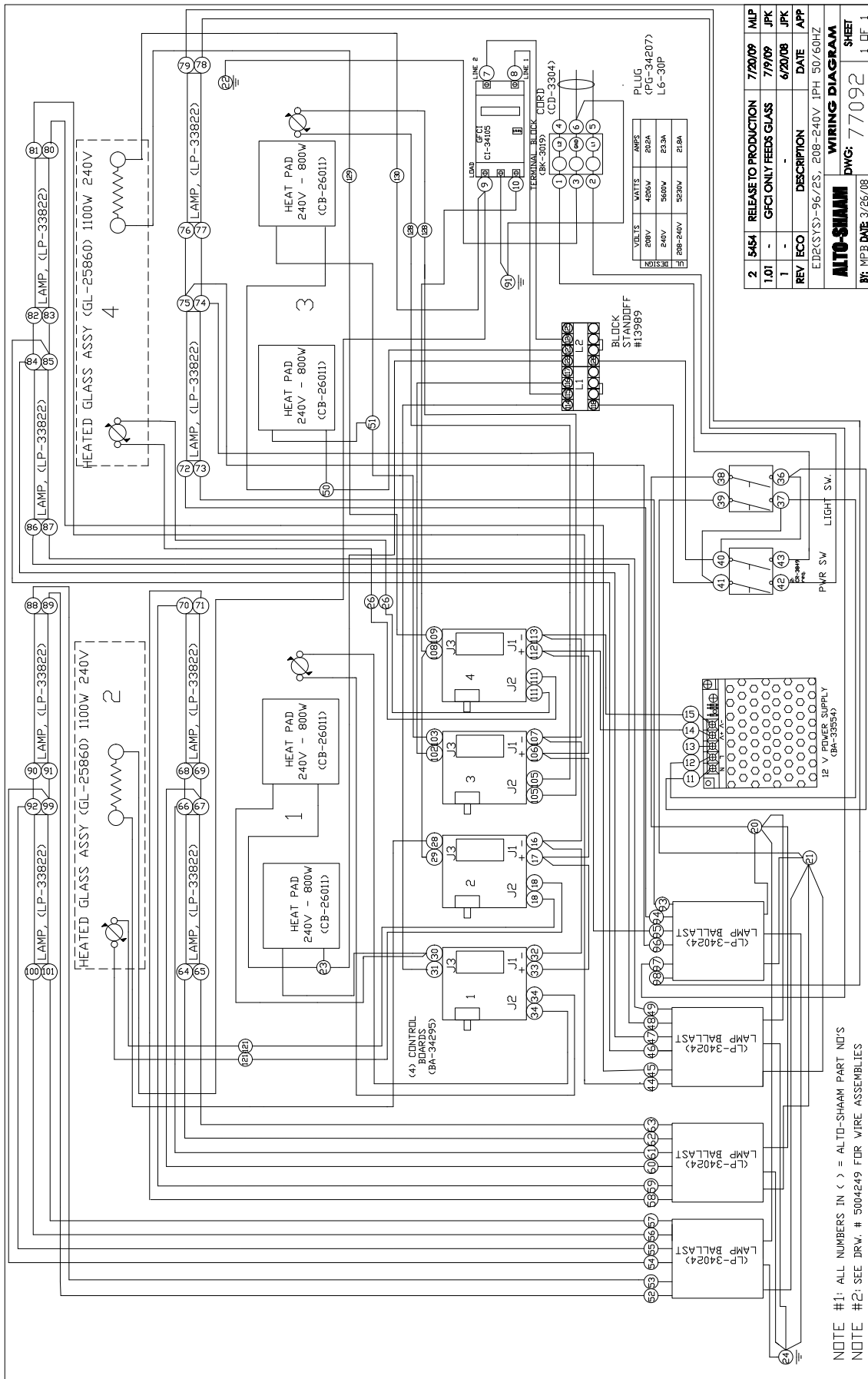

REV	ECO	DESCRIPTION	DATE	APP
2	1544	RELEASE TO PRODUCTION	7/20/09	MJP
1.01	-	GFCI ONLY FEEDS GLASS	7/9/09	JPK
1	-	-	6/20/08	JPK

ED2(SYS)-96/2S	208-240V	1PH	50/60HZ
PLUG	(P-G-34207)		
L6-30P			

WIRE TYPE	WIRE SIZE	WIRE COLOR	WIRE PART NUMBER
WIRE 1	20	RED	BA-34295
WIRE 2	20	BLACK	BA-34295
WIRE 3	20	WHITE	BA-34295
WIRE 4	20	BLUE	BA-34295
WIRE 5	20	GREEN	BA-34295
WIRE 6	20	BROWN	BA-34295
WIRE 7	20	PURPLE	BA-34295
WIRE 8	20	PINK	BA-34295
WIRE 9	20	YELLOW	BA-34295
WIRE 10	20	ORANGE	BA-34295
WIRE 11	20	GREY	BA-34295
WIRE 12	20	TEAL	BA-34295
WIRE 13	20	SLATE	BA-34295
WIRE 14	20	MAUVE	BA-34295
WIRE 15	20	SPARKLING	BA-34295
WIRE 16	20	PERLA	BA-34295
WIRE 17	20	PERLA	BA-34295
WIRE 18	20	PERLA	BA-34295
WIRE 19	20	PERLA	BA-34295
WIRE 20	20	PERLA	BA-34295
WIRE 21	20	PERLA	BA-34295
WIRE 22	20	PERLA	BA-34295
WIRE 23	20	PERLA	BA-34295
WIRE 24	20	PERLA	BA-34295
WIRE 25	20	PERLA	BA-34295
WIRE 26	20	PERLA	BA-34295
WIRE 27	20	PERLA	BA-34295
WIRE 28	20	PERLA	BA-34295
WIRE 29	20	PERLA	BA-34295
WIRE 30	20	PERLA	BA-34295
WIRE 31	20	PERLA	BA-34295
WIRE 32	20	PERLA	BA-34295
WIRE 33	20	PERLA	BA-34295
WIRE 34	20	PERLA	BA-34295
WIRE 35	20	PERLA	BA-34295
WIRE 36	20	PERLA	BA-34295
WIRE 37	20	PERLA	BA-34295
WIRE 38	20	PERLA	BA-34295
WIRE 39	20	PERLA	BA-34295
WIRE 40	20	PERLA	BA-34295
WIRE 41	20	PERLA	BA-34295
WIRE 42	20	PERLA	BA-34295
WIRE 43	20	PERLA	BA-34295
WIRE 44	20	PERLA	BA-34295
WIRE 45	20	PERLA	BA-34295
WIRE 46	20	PERLA	BA-34295
WIRE 47	20	PERLA	BA-34295
WIRE 48	20	PERLA	BA-34295
WIRE 49	20	PERLA	BA-34295
WIRE 50	20	PERLA	BA-34295
WIRE 51	20	PERLA	BA-34295
WIRE 52	20	PERLA	BA-34295
WIRE 53	20	PERLA	BA-34295
WIRE 54	20	PERLA	BA-34295
WIRE 55	20	PERLA	BA-34295
WIRE 56	20	PERLA	BA-34295
WIRE 57	20	PERLA	BA-34295
WIRE 58	20	PERLA	BA-34295
WIRE 59	20	PERLA	BA-34295
WIRE 60	20	PERLA	BA-34295
WIRE 61	20	PERLA	BA-34295
WIRE 62	20	PERLA	BA-34295
WIRE 63	20	PERLA	BA-34295
WIRE 64	20	PERLA	BA-34295
WIRE 65	20	PERLA	BA-34295
WIRE 66	20	PERLA	BA-34295
WIRE 67	20	PERLA	BA-34295
WIRE 68	20	PERLA	BA-34295
WIRE 69	20	PERLA	BA-34295
WIRE 70	20	PERLA	BA-34295
WIRE 71	20	PERLA	BA-34295
WIRE 72	20	PERLA	BA-34295
WIRE 73	20	PERLA	BA-34295
WIRE 74	20	PERLA	BA-34295
WIRE 75	20	PERLA	BA-34295
WIRE 76	20	PERLA	BA-34295
WIRE 77	20	PERLA	BA-34295
WIRE 78	20	PERLA	BA-34295
WIRE 79	20	PERLA	BA-34295
WIRE 80	20	PERLA	BA-34295
WIRE 81	20	PERLA	BA-34295
WIRE 82	20	PERLA	BA-34295
WIRE 83	20	PERLA	BA-34295
WIRE 84	20	PERLA	BA-34295
WIRE 85	20	PERLA	BA-34295
WIRE 86	20	PERLA	BA-34295
WIRE 87	20	PERLA	BA-34295
WIRE 88	20	PERLA	BA-34295
WIRE 89	20	PERLA	BA-34295
WIRE 90	20	PERLA	BA-34295
WIRE 91	20	PERLA	BA-34295
WIRE 92	20	PERLA	BA-34295
WIRE 93	20	PERLA	BA-34295
WIRE 94	20	PERLA	BA-34295
WIRE 95	20	PERLA	BA-34295
WIRE 96	20	PERLA	BA-34295
WIRE 97	20	PERLA	BA-34295
WIRE 98	20	PERLA	BA-34295
WIRE 99	20	PERLA	BA-34295
WIRE 100	20	PERLA	BA-34295

NOTE #1: ALL NUMBERS IN ( ) = ALTO-SHAAM PART NO'S  
 NOTE #2: SEE DRW. # 5004249 FOR WIRE ASSEMBLIES

# TRANSPORTATION DAMAGE and CLAIMS



All Alto-Shaam equipment is sold F.O.B. shipping point, and when accepted by the carrier, such shipments become the property of the consignee.

Should damage occur in shipment, it is a matter between the carrier and the consignee. In such cases, the carrier is assumed to be responsible for the safe delivery of the merchandise, unless negligence can be established on the part of the shipper.

1. Make an immediate inspection while the equipment is still in the truck or immediately after it is moved to the receiving area. Do not wait until after the material is moved to a storage area.
2. Do not sign a delivery receipt or a freight bill until you have made a proper count and inspection of all merchandise received.
3. Note all damage to packages directly on the carrier's delivery receipt.
4. Make certain the driver signs this receipt. If he refuses to sign, make a notation of this refusal on the receipt.
5. If the driver refuses to allow inspection, write the following on the delivery receipt:  
*Driver refuses to allow inspection of containers for visible damage.*
6. Telephone the carrier's office immediately upon finding damage, and request an inspection. Mail a written confirmation of the time, date, and the person called.
7. Save any packages and packing material for further inspection by the carrier.
8. Promptly file a written claim with the carrier and attach copies of all supporting paperwork.

We will continue our policy of assisting our customers in collecting claims which have been properly filed and actively pursued. We cannot, however, file any damage claims for you, assume the responsibility of any claims, or accept deductions in payment for such claims.

## LIMITED WARRANTY

Alto-Shaam, Inc. warrants to the original purchaser only that any original part that is found to be defective in material or workmanship will, at Alto-Shaam's option, subject to provisions hereinafter stated, be replaced with a new or rebuilt part.

### The parts warranty period is as follows:

For the refrigeration compressor on Alto-Shaam Quickchillers™, five (5) years from the date of installation.

For the heating element on Halo Heat® cook/hold ovens, as long as the original purchaser owns the oven.

For all other parts, one (1) year from the date of installation or fifteen (15) months from the shipping date, whichever occurs first.

The labor warranty period is one (1) year from the date of installation or fifteen (15) months from the shipping date, whichever occurs first.

Alto-Shaam will bear normal labor charges performed during standard business hours, excluding overtime, holiday rates or any additional fees.

To be valid, a warranty claim must be asserted during the applicable warranty period. This warranty is not transferable.

### THIS WARRANTY DOES NOT APPLY TO:

1. Calibration.
2. Replacement of light bulbs, door gaskets, and/or the replacement of glass due to damage of any kind.
3. Equipment damage caused by accident, shipping, improper installation or alteration.
4. Equipment used under conditions of abuse, misuse, carelessness or abnormal conditions, including but not limited to, equipment subjected to harsh or inappropriate chemicals, including but not limited to, compounds containing chloride or quaternary salts, poor water quality, or equipment with missing or altered serial numbers.
5. Damage incurred as a direct result of poor water quality, inadequate maintenance of steam generators and/or surfaces affected by water quality. Water quality and required maintenance of steam generating equipment is the responsibility of the owner/operator.
6. Damage caused by use of any cleaning agent other than Alto-Shaam's Combitherm® Cleaner, including but not limited to damage due to chlorine or other harmful chemicals. **Use of Alto-Shaam's Combitherm® Cleaner on Combitherm® ovens is highly recommended.**
7. Any losses or damage resulting from malfunction, including loss of product or consequential or incidental damages of any kind.
8. Equipment modified in any manner from original model, substitution of parts other than factory authorized parts, removal of any parts including legs, or addition of any parts.

This warranty is exclusive and is in lieu of all other warranties, express or implied, including the implied warranties of merchantability and fitness for a particular purpose. In no event shall Alto-Shaam be liable for loss of use, loss of revenue or profit, or loss of product, or for any indirect, special, incidental, or consequential damages. No person except an officer of Alto-Shaam, Inc. is authorized to modify this warranty or to incur on behalf of Alto-Shaam any other obligation or liability in connection with Alto-Shaam equipment.

Effective 09/10



RECORD THE MODEL AND SERIAL NUMBER OF THE APPLIANCE FOR EASY REFERENCE.

ALWAYS REFER TO BOTH MODEL AND SERIAL NUMBER IN ANY CONTACT WITH ALTO-SHAAM REGARDING THIS APPLIANCE.

Model: \_\_\_\_\_ Date Installed: \_\_\_\_\_  
Voltage: \_\_\_\_\_ Purchased From: \_\_\_\_\_  
Serial Number: \_\_\_\_\_

W164 N9221 Water Street • P.O. Box 450 • Menomonee Falls, Wisconsin 53052-0450 • U.S.A.

PHONE: 262.251.3800 • 800.558-8744 USA/CANADA FAX: 262.251.7067 • 800.329.8744 U.S.A. ONLY

www.alto-shaam.com

PRINTED IN U.S.A.