



# CATALOG OF REPLACEMENT PARTS



## MODELS HCM300 & HCM450 CUTTER/MIXERS

(INCLUDES MOTOR PARTS)

HCM300	ML-32312
HCM450	ML-32313
HCM450C	ML-134071

**Table of Contents**

<b>Page</b>	<b>Description</b>
3	Miscellaneous
4	Motor and Frame Unit
7	Knife Unit
9	Bowl Lid Unit (ML-32312)
11	Bowl Lid Unit (ML-32313 & ML-134071)
12	Control Box Unit
15	Brake and Bowl Unit
17	Handle Lock Unit
19	Motor Parts

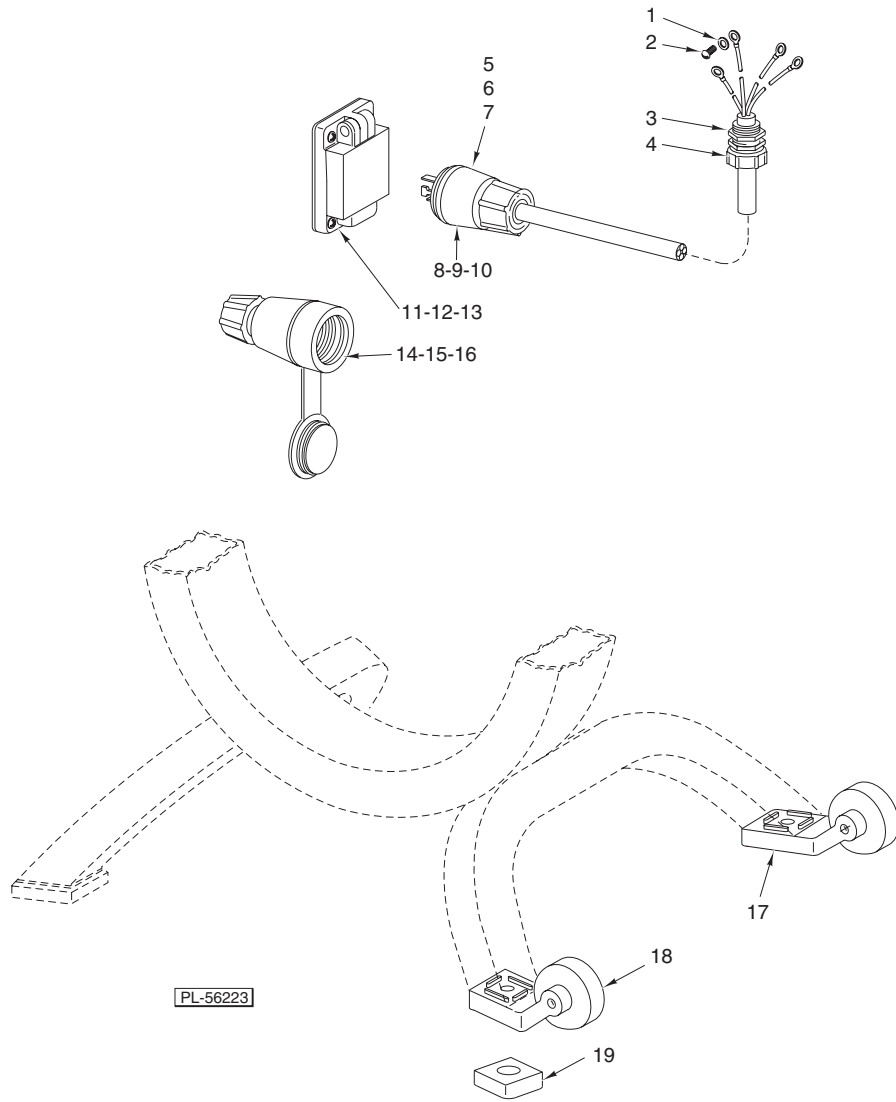

**MISCELLANEOUS**

ILLUS.	PART NO.	NAME OF PART	AMT.
	PL-56223		
1	WL-007-07	Lockwasher #8 External Shakeproof .....	1
2	SC-009-56	Mach. Screw 8-32 x 3/8 Slotted Rd. Hd. ....	1
3	FE-007-12	Lock Nut 3/4 Cnd .....	1
4	FE-014-14	Strain Relief .....	1
5	00-124586	Plug & Cover (200 V.) .....	1
6	00-117611-00009	Plug - 3 Phase (460 V.) .....	1
7	00-117611-00008	Plug - 3 Phase (230 V.) .....	1
8	00-117612-00008	Cord & Plug Assy. (230 V.) (Incls. Item 7) .....	1
9	00-117612-00009	Cord & Plug Assy. (460 V.) (Incls. Item 6) .....	1
10	00-122292-00001	Cord & Plug Assy. (200 V.) (Incls. Item 5) .....	1
11	00-117631-00001	Receptacle (230 V.) .....	1
12	00-117631-00002	Receptacle (460 V.) .....	1
13	00-123816-00001	Receptacle & Cover Assy. (200 V.) .....	1
14	00-117625-00001	Connector (230 V.) .....	1
15	00-117625-00002	Connector (460 V.) .....	1
16	00-123805-00001	Connector & Cover Assy. (200 V.) (Not Shown) .....	1
17	00-123658-00002	Caster Assy. (Right) .....	1
18	00-123658-00001	Caster Assy. (Left) .....	1
19	00-123813	Pad - Caster .....	2
	00-123659	Caster Set (Incls. Items 17, 18, & 19) .....	1

HMC300 & HMC450 CUTTER/MIXERS REPLACEMENT PARTS

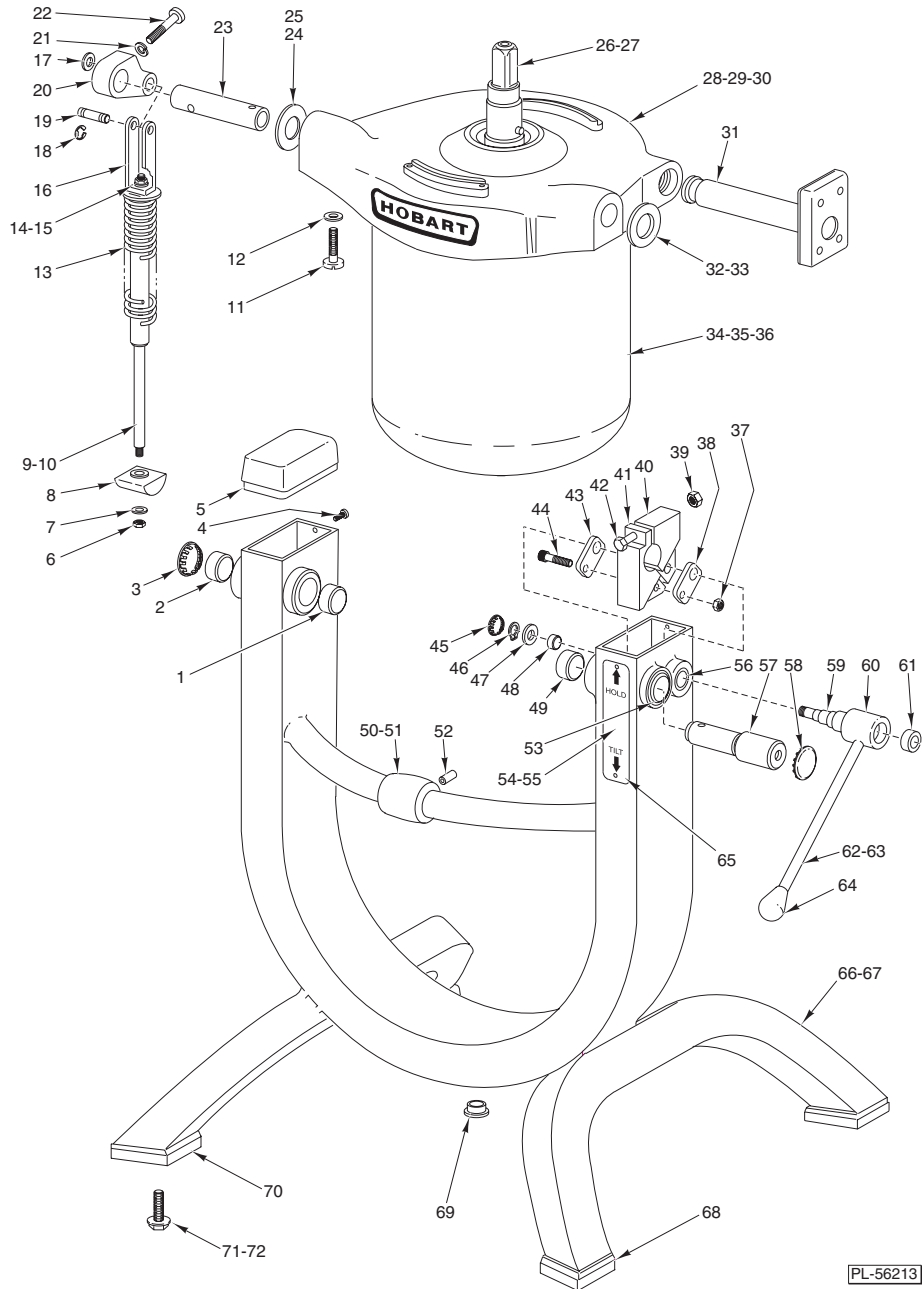

MOTOR AND FRAME UNIT

ILLUS.	PART NO.	NAME OF PART	AMT.
PL-56213			
1	00-108394-00041	Sleeve Bearing (1.25 In. O.D.) .....	1
2	00-108394-00041	Sleeve Bearing (1.25 In. O.D.) .....	1
3	PB-004-04	Plug - Button (1 1/4) .....	1
4	00-123109	Screw - Serrated Head 6-32 x 3/8 .....	4
5	00-122167	Cap - Tube .....	2
6	NS-031-20	Stop Nut 1/4-20 Elastic .....	1
7	WS-003-49	Washer .....	1
8	00-122185	Pivot Pad & Bearing Assy. ....	1
9	00-122178	Counter Balance Assy. (Incls. Items 6, 7, 8, 10, 13, 14, 15, & 16) .....	1
10	00-122183	Rod - Spring Guide .....	1
11	SC-092-62	Cap Screw 3/8-16 x 1 1/2 Soc. Fil. Hd. ....	2
12	WL-004-06	Lockwasher 3/8 Medium .....	2

## MOTOR AND FRAME UNIT (Cont.)

ILLUS.	PART NO.	NAME OF PART	AMT.
PL-56213			
13	00-122184-00001	Spring – Compression .....	1
14	NS-031-20	Stop Nut 1/4-20 Elastic .....	1
15	WS-003-49	Washer .....	1
16	00-122179	Yoke & Spring Guide Assy. ....	1
17	WS-024-01	Washer .....	1
18	RR-004-25	Retaining Ring .....	2
19	00-122189	Shaft – Yoke .....	1
20	00-122187	Crank & Bearing Assy. ....	1
21	WL-004-06	Lockwasher 3/8 Medium .....	1
22	SC-110-08	Cap Screw 3/8-16 x 1 3/4 Hex Soc. Hd. ....	1
23	00-122177	Shaft – Left Pivot .....	1
24	00-124740-00001	Spacer – Frame .....	1
25	00-124740-00002	Spacer – Frame .....	AR
26	00-122496-00003	Motor Assy. (200/400 V.) (Incls. Items 28, 29, & 30) .....	1
27	00-122496-00004	Motor Assy. (230/460 V.) (Incls. Items 28, 29, & 30) .....	1
28	00-122370	Bearing Bracket & Logo Assy. ....	1
29	00-117858-00002	Loop Decal .....	2
30	00-121676-00001	Rivet .....	4
31	00-122199	Tube & Plate Assy. ....	1
32	00-124740-00001	Spacer – Frame .....	1
33	00-124740-00002	Spacer – Frame .....	AR
34	00-122175-00001	Motor Cover Assy. ....	1
35	SC-021-91	Mach. Screw 8-32 x 5/16 Slotted Rd. Hd. (SST) .....	3
36	SC-121-92	Mach. Screw 8-32 x 3/8 Hex Button Hd. (SST) (ML-134071) .....	3
37	NS-013-14	Nut 5/16 Hex Fin. ....	1
38	00-122299	Front Link & Bushing Assy. ....	1
39	NS-032-18	Stop Nut 3/8-16 Flexloc .....	1
40	00-123560	Clamp Assy. (Right) .....	1
41	00-122297	Clamp Assy. (Left) .....	1
42	SC-036-66	Cap Screw 3/8-16 x 3 Hex Hd. ....	1
43	00-122298	Back Link & Bushing Assy. ....	1
44	00-122269	Screw – Socket Shoulder .....	1
45	PB-004-02	Plug Button (1 5/16) .....	1
46	RR-004-05	Retaining Ring .....	1
47	WS-029-19	Washer .....	1
48	00-108394-00037	Sleeve Bearing (0.628 In. O.D.) .....	1
49	00-108394-00041	Sleeve Bearing (1.25 In. O.D.) .....	1
50	00-122166	Bumper – Stop (HCM300) (Not Shown) .....	1
51	00-122161	Bumper – Stop (HCM450) .....	1
52	RP-006-01	Rollpin 3/8 Dia. x 3/4 Lg. ....	1
53	00-108394-00043	Sleeve Bearing (1.502 In. O.D.) .....	1
54	00-123610	Label – Hold/Tilt .....	1
55	00-124938	Label 50 Hz. ....	1
56	00-108394-00045	Sleeve Bearing (0.878 In. O.D.) .....	1
57	00-122176	Shaft – Right Pivot .....	1
58	PB-004-05	Plug Button (1 1/2) .....	1
59	00-122195	Shaft – Lock .....	1
60	00-122196	Collar – Shaft .....	1
61	00-123812	Magnet – Ring .....	1
62	00-122197	Handle – Lock .....	1
63	00-477100	Tilt Handle Weldment (ML-134071) (Not Shown) .....	1
64	00-123173	Knob .....	1
65	00-121676-00001	Screw .....	2
66	00-122151-00001	Frame Assy. (Incls. Items 1, 2, 48, 49, 52, 53, 54, 56, 65, & 69) .....	1
67	00-122151-00002	Frame Assy. 50 Hz. (Incls. Items 1, 2, 48, 49, 52, 53, 55, 56, 65, & 69) .....	1
68	00-122164	Foot (#1) .....	2
69	00-123772	Plug – Vent .....	1
70	00-122165	Foot (#2) .....	2
71	WS-021-09	Washer .....	4
72	SC-117-97	Cap Screw 1/2-13 x 1 Hex Hd. ....	4
	00-124361	Feet Set (Incls. Items 69, 71, 72, & 73) .....	1
	00-122198	Tilt Lock Handle Assy. (Incls. Items 60 thru 63 & 65) .....	1

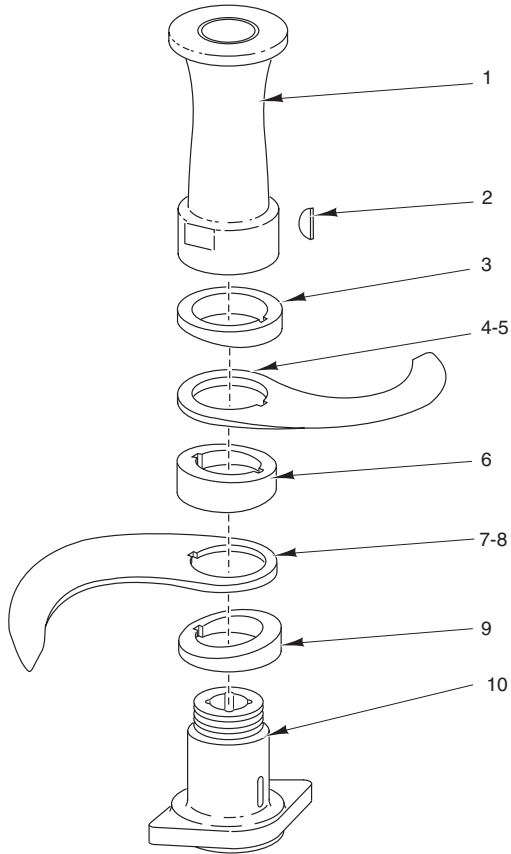

**CUT/MIX**

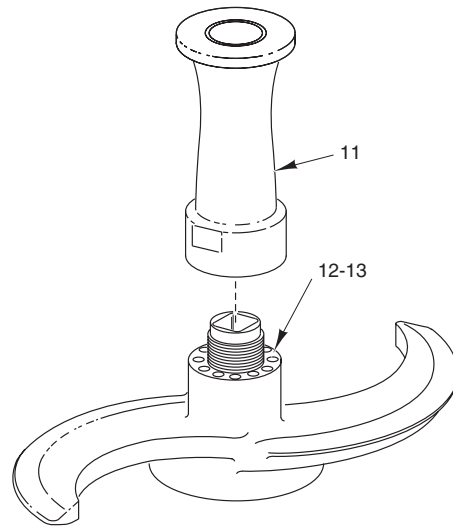

**KNEAD/MIX**

PL-56215

**KNIFE UNIT**

**KNIFE UNIT**

ILLUS.	PART NO.	NAME OF PART	AMT.
PL-56215			
1	00-291957	Sleeve – Blade Locking .....	1
2	KW-004-01	Key #1008 Woodruff .....	2
3	00-122290	Block – Single Angle .....	1
4	00-274661	Knife (HCM300) .....	1
5	00-274662	Knife (HCM450) .....	1
6	00-122291	Block – Double Angle .....	1
7	00-274661	Knife (HCM300) .....	1
8	00-274662	Knife (HCM450) .....	1
9	00-122290	Block – Single Angle .....	1
10	00-124265	Hub – Square Drive .....	1
11	00-291957	Sleeve – Blade Locking .....	1
12	00-124647-00001	Blade/Hub – Knead/Mix (HCM450) .....	1
13	00-124647-00002	Blade/Hub – Knead/Mix (HCM300 & 450) .....	1
	00-292035-00002	Cut/Mix Shaft Assy. (HCM300) (Incls. Items 1, 2, 3, 4, 6, 7, 9, & 10) .....	1
	00-292035-00001	Cut/Mix Shaft Assy. (HCM450) (Incls. Items 1, 2, 3, 5, 6, 8, 9, & 10) .....	1
	00-292028	Knead/Mix Blade & Sleeve Assy. (Standard) (HCM300 & 450) (Incls. Items 11 & 13) .....	1
	00-292029	Knead/Mix Blade & Sleeve Assy. (HCM450) (Incls. Items 11 & 12) .....	1

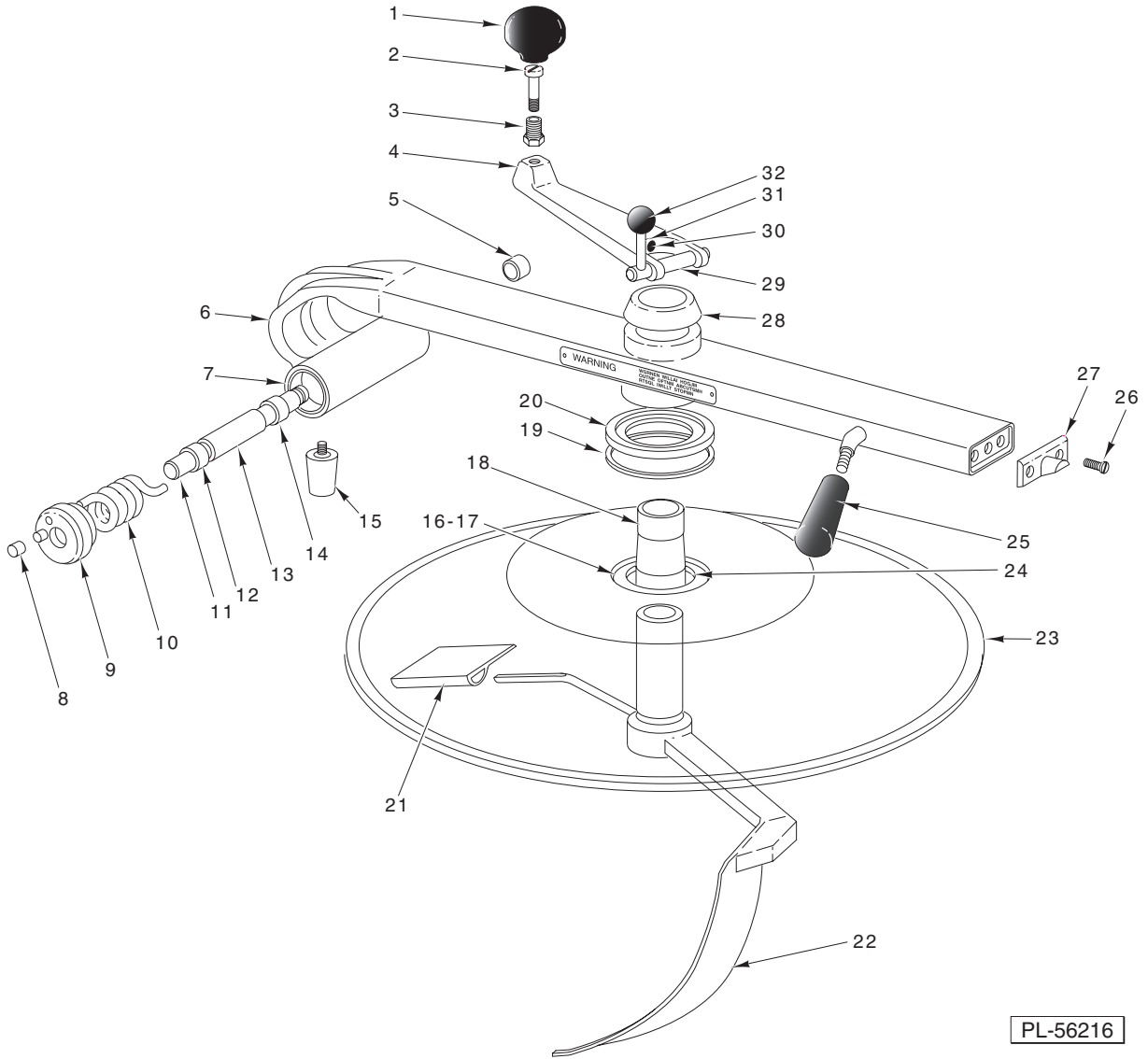

**BOWL LID UNIT (ML-32312)**



## BOWL LID UNIT (ML-32312)

ILLUS.	PART NO.	NAME OF PART	AMT.
PL-56216			
1	00-123174	Knob .....	1
2	00-124356	Stud – Handle .....	1
3	00-124469	Insert – Handle .....	1
4	00-123574	Handle Assy. (Incls. Items 1, 2, 3, & 29 thru 32) .....	1
5	00-110544-00007	Bushing (0.718 In. O.D.) .....	1
6	00-290702-00002	Lid Handle Assy. (Incls. Items 5 & 7) .....	1
7	00-110544-00008	Bushing (1.656 In. O.D.) .....	1
8	00-290921	Bushing – Lid Spring .....	1
9	00-123666	Spring Cap Assy. ....	1
10	00-122267	Spring – Torsion .....	1
11	00-122265	Shaft – Spring Pivot .....	1
12	00-108394-00044	Sleeve Bearing (0.878 In. O.D.) .....	1
13	00-122310	Sleeve .....	1
14	00-108394-00044	Sleeve Bearing (0.878 In. O.D.) .....	1
15	00-122264	Bumper – Lid .....	1
16	00-290695	Ring – Lid Support (Lower) .....	1
17	00-291370	Gasket – Support Ring .....	1
18	00-124841	Bearing – Baffle .....	1
19	00-291370	Gasket – Support Ring .....	1
20	00-290696	Ring – Lid Support (Upper) .....	1
21	00-122209-00002	Scraper .....	1
22	00-123757	Baffle Bar & Blade Assy. ....	1
*23	00-290684	Lid .....	1
24	SC-022-68	Mach. Screw 10-32 x 5/8 Slotted Flat Hd. (SST) .....	3
25	00-123172	Handle .....	1
26	SC-119-58	Mach. Screw 1/4-20 x 1/2 Slotted Pan Hd. (SST) .....	2
27	00-290604	Plate – Lock .....	1
28	00-122587	Bushing – Cap .....	1
29	00-122315	Pin – Baffle Lock .....	1
30	SC-118-52	Set Screw 1/4-20 x 1/2 Slotted Hdls., Cup Pt. Long-Loc .....	1
31	00-122586	Handle – Baffle Lock .....	1
32	00-077401	Knob .....	1

\*No Longer Available – Order Lid Kit P/N 271914.

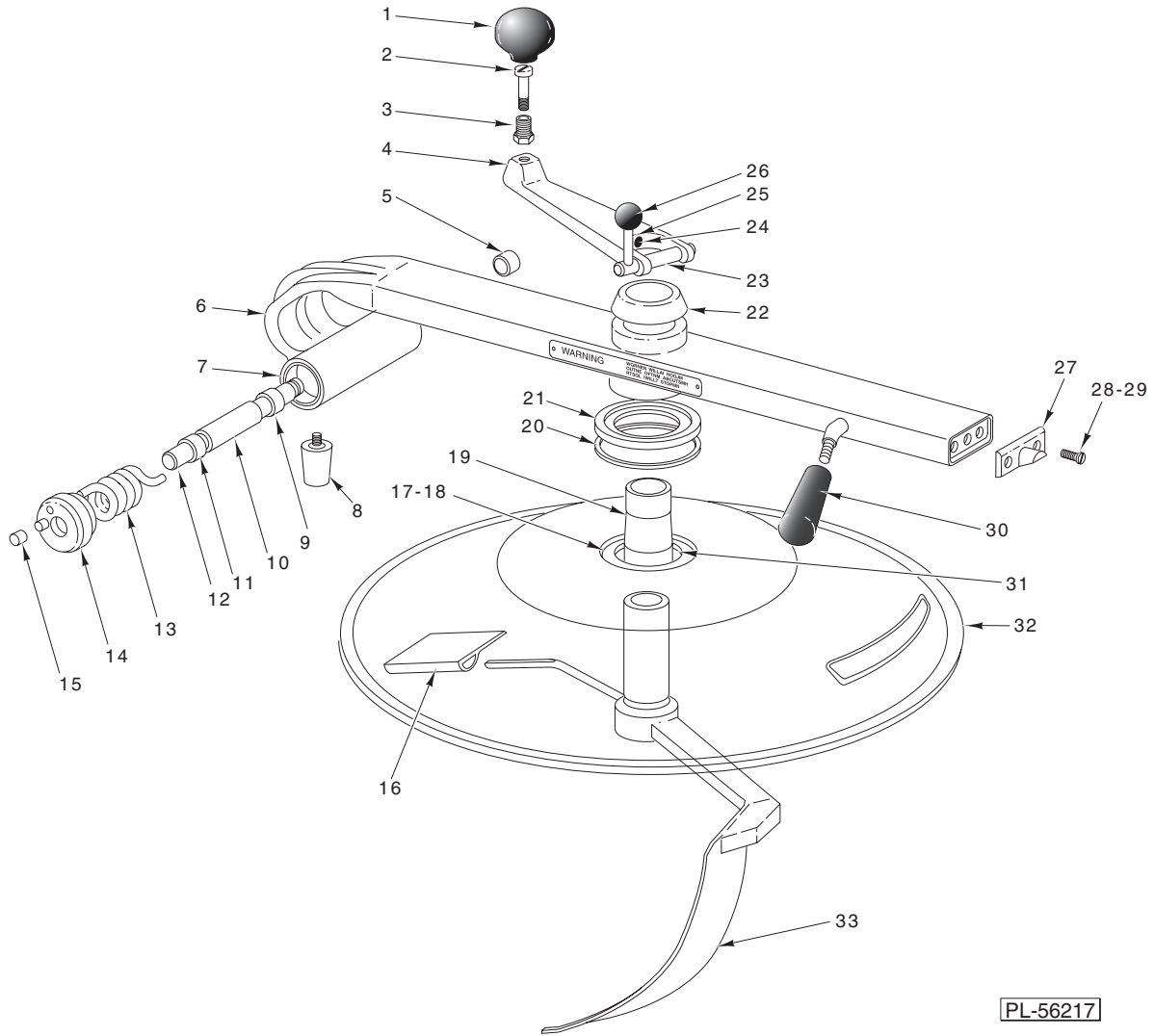

**BOWL LID UNIT  
(ML-32313 & ML-134071)**

**BOWL LID UNIT  
(ML-32313 & ML-134071)**

ILLUS. PL-56217	PART NO.	NAME OF PART	AMT.
1	00-123174	Knob .....	1
2	00-124356	Stud – Handle .....	1
3	00-124469	Insert – Handle .....	1
4	00-123574	Baffle Handle Assy. (Incls. Items 1, 2, 3, & 23 thru 26) .....	1
5	00-110544-00007	Bushing (0.718 In. O.D.) .....	1
6	00-290702-00001	Lid Handle Assy. (Incls. Items 5 & 7) .....	1
7	00-110544-00008	Bushing (1.656 In. O.D.) .....	1
8	00-122264	Bumper – Lid .....	1
9	00-108394-00044	Sleeve Bearing (0.878 In. O.D.) .....	1
10	00-122310	Sleeve .....	1
11	00-108394-00044	Sleeve Bearing (0.878 In. O.D.) .....	1
12	00-122265	Shaft – Spring Pivot .....	1
13	00-122267	Spring – Torsion .....	1
14	00-123666	Spring – Cap Assy. ....	1
15	00-290921	Bushing – Lid Spring .....	1
16	00-122209-00001	Scraper .....	1
17	00-290695	Ring – Lid Support (Lower) .....	1
18	00-291370	Gasket – Support Ring .....	1
19	00-124841	Bearing – Baffle .....	1
20	00-291370	Gasket – Support Ring .....	1
21	00-290696	Ring – Lid Support (Upper) .....	1
22	00-122587	Bushing – Cap .....	1
23	00-122315	Pin – Baffle Lock .....	1
24	SC-118-52	Set Screw $\frac{1}{4}$ -20 x $\frac{1}{2}$ Hdls., Cup Pt. Long-Loc .....	1
25	00-122586	Handle – Baffle Lock .....	1
26	00-077401	Knob .....	1
27	00-290604	Plate – Lock .....	1
28	SC-119-58	Mach. Screw $\frac{1}{4}$ -20 x $\frac{1}{2}$ Pan Hd. ....	2
29	SC-122-52	Mach. Screw $\frac{1}{4}$ -20 x $\frac{3}{8}$ Hex Button Hd. (ML-134071) .....	2
30	00-123172	Handle .....	1
31	SC-022-68	Mach. Screw 10-32 x $\frac{5}{8}$ Flat Hd. ....	3
*32	00-290685	Lid .....	1
33	00-292808	Baffle Bar & Blade Assy. ....	1
	00-438131-00100	Label – Warning (Rotating Knives) .....	1

\*No Longer Available – Order Lid Kit P/N 292797.

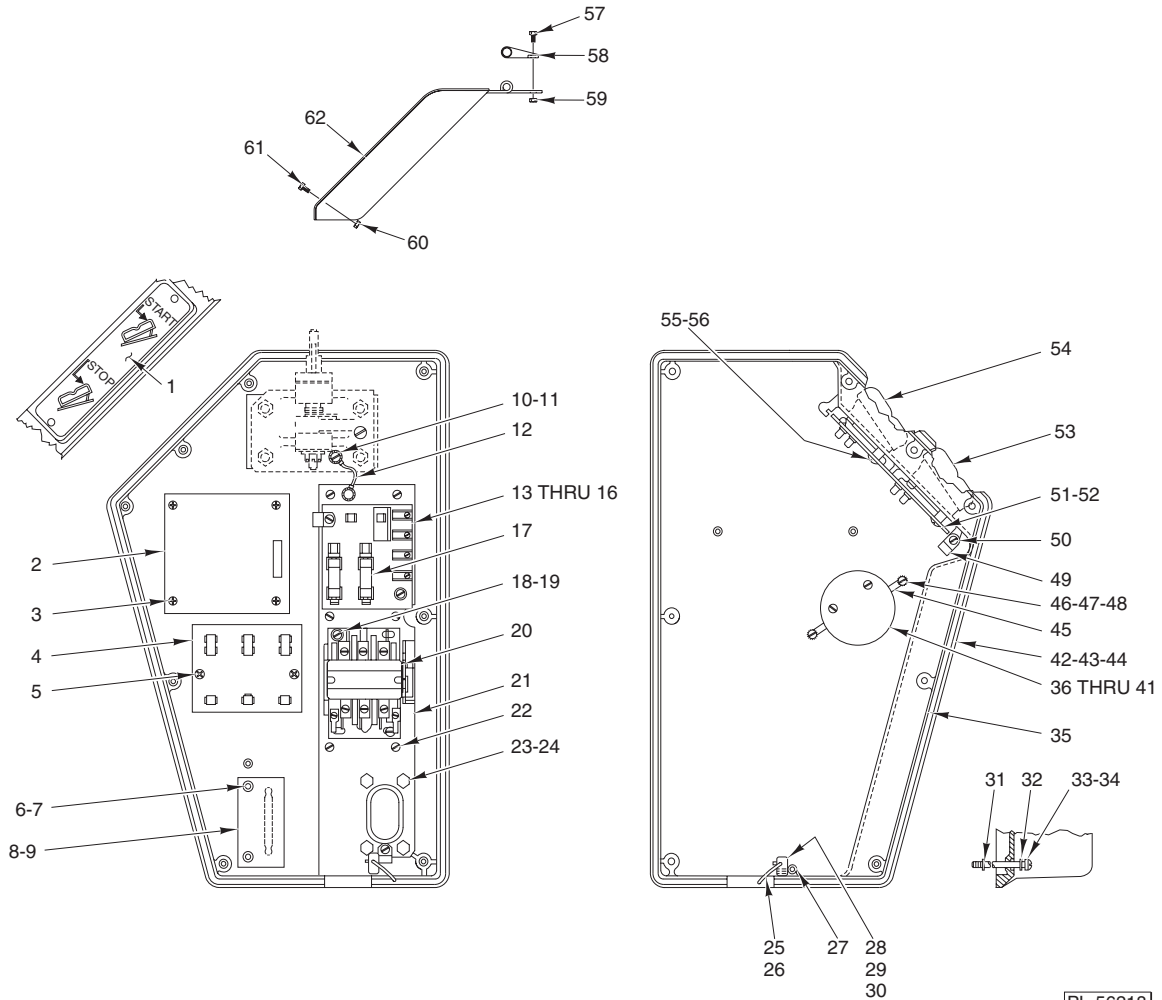

**CONTROL BOX UNIT**

ILLUS.	PART NO.	NAME OF PART	AMT.
PL-56218			
1	00-290645	Control Box & Label Assy. ....	1
2	00-278328	Motor Protection Board Assy. ....	1
3	SD-013-07	Self-Tapping Screw 6-20 x 5/16 Phil. Pan Hd., Type BT ....	4
4	00-121014	Board – Terminal ....	1
5	SD-033-05	Self-Tapping Screw 10-16 x 1/2 Slotted Rd. Hd., Type BT ....	2
6	SD-013-07	Self-Tapping Screw 6-20 x 5/16 Phil. Pan Hd., Type BT ....	2
7	WS-028-01	Washer ....	2
8	00-122218	Reed Mounting Board Assy. (Incls. Item 9) ....	1

## CONTROL BOX UNIT

ILLUS.	PART NO.	NAME OF PART	AMT.
PL-56218			
9	00-111964	Switch – Reed .....	1
10	SC-008-09	Mach. Screw 10-24 x <sup>3</sup> / <sub>8</sub> Slotted Rd. Hd. ....	1
11	WL-007-12	Lockwasher #10 External Shakeproof .....	1
12	00-123648-00006	Lead Wire Assy. (Ground) .....	1
13	00-117034-00007	Power Input Board Assy. (Incls. Item 17) .....	1
14	SC-008-09	Mach. Screw 10-24 x <sup>3</sup> / <sub>8</sub> Slotted Rd. Hd. ....	3
15	WL-007-12	Lockwasher #10 External Shakeproof .....	1
16	FE-022-63	Fuse (3 Amp., 32 V.) .....	1
17	FE-024-16	Fuse – Fiber Tube (0.8 Amp., BBS-8) .....	2
18	SC-008-09	Mach. Screw 10-24 x <sup>3</sup> / <sub>8</sub> Slotted Rd., Hd. ....	2
19	WL-007-12	Lockwasher #10 External Shakeproof .....	1
20	00-121926-00002	Contactorm .....	1
21	00-124042	Control Mounting Bracket Assy. ....	1
22	SD-033-04	Self-Tapping Screw 10-16 x <sup>3</sup> / <sub>8</sub> Phil. Rd. Hd., Type BT .....	6
23	SC-037-85	Cap Screw <sup>9</sup> / <sub>16</sub> -18 x 1 Hex Hd. ....	4
24	WL-003-47	Lockwasher <sup>5</sup> / <sub>16</sub> Medium .....	4
25	00-118234-00005	Cable (5.625 In. Lg.) .....	1
26	00-118233	Ferrule (Double) .....	2
27	00-078752-00003	Clamp .....	1
28	00-122268	Bracket – Cable .....	1
29	SC-009-69	Mach. Screw 6-32 x <sup>1</sup> / <sub>2</sub> Slotted Rd. Hd. ....	1
30	NS-009-07	Mach. Nut 6-32 Hex .....	1
31	WS-029-20	Washer .....	8
32	00-067500-00038	O-Ring .....	8
33	00-290354	Insulated Screw Assy. (1 <sup>3</sup> / <sub>4</sub> In. Lg.) .....	5
34	00-290353	Insulated Screw Assy. (4 <sup>1</sup> / <sub>2</sub> In. Lg.) .....	3
35	00-292612	Gasket – Control Box Lid .....	1
36	00-124692	Timer W/Bell (6 Min. Timer) .....	1
37	00-294650-004-9	Timer (5 Min. Elec. Timer) .....	1
38	00-292350	Plate – Indicator .....	1
39	SC-025-18	Mach. Screw 5-40 x <sup>1</sup> / <sub>2</sub> Slotted Bndg. Hd. (SST) .....	2
40	00-292349-00001	Timer Knob (5 Min. Timer) .....	1
41	00-124683	Timer Knob (6 Min. Timer) .....	1
42	00-123910	Control Box Lid & Logo Assy. (Non-Timed Machine) (Incls. Item 35) .....	1
43	00-290046	Control Box Lid & Logo Assy. (6 Min. Timer) .....	1
44	00-292490	Control Box Lid & Logo Assy. (5 Min. Elec. Timer) (Incls. Item 35) .....	1
45	00-124826	Guard – Timer Knob .....	1
46	SC-019-33	Mach. Screw 8-32 x <sup>1</sup> / <sub>2</sub> Slotted Bndg. Hd. ....	2
47	WL-007-07	Lockwasher #8 External Shakeproof .....	2
48	00-067500-00038	O-Ring .....	2
49	00-078752-00006	Clamp .....	1
50	SD-033-03	Self-Tapping Screw 6-20 x <sup>1</sup> / <sub>2</sub> Slotted Rd. Hd., Type BT .....	1
51	00-278318	Reed Mounting Board Assy. (Incls. Item 54) .....	1
52	00-111964	Switch – Reed .....	2
53	00-120872-00004	Switch Assy. (Stop) .....	1
54	00-120872-00002	Switch Assy. (Start) .....	1
55	SD-009-40	Self-Tapping Screw 6-32 x <sup>3</sup> / <sub>4</sub> Phil. Pan Hd., Type F .....	4
56	00-290096	Spacer – Standoff .....	4
57	SC-121-97	Mach. Screw 10-24 x <sup>3</sup> / <sub>4</sub> Hex Button Hd. (SST) (ML-134071) .....	2
58	00-438247	Hasp – Weldment (ML-134071) .....	1
59	NS-038-13	Lock Nut 10-24 (ML-134071) .....	2
60	NS-038-13	Lock Nut 10-24 (ML-134071) .....	2
61	SC-121-97	Mach. Screw 10-24 x <sup>3</sup> / <sub>4</sub> Hex Button Hd. (SST) (ML-134071) .....	2
62	00-438242	Cover – Weldment (ML-134071) .....	1

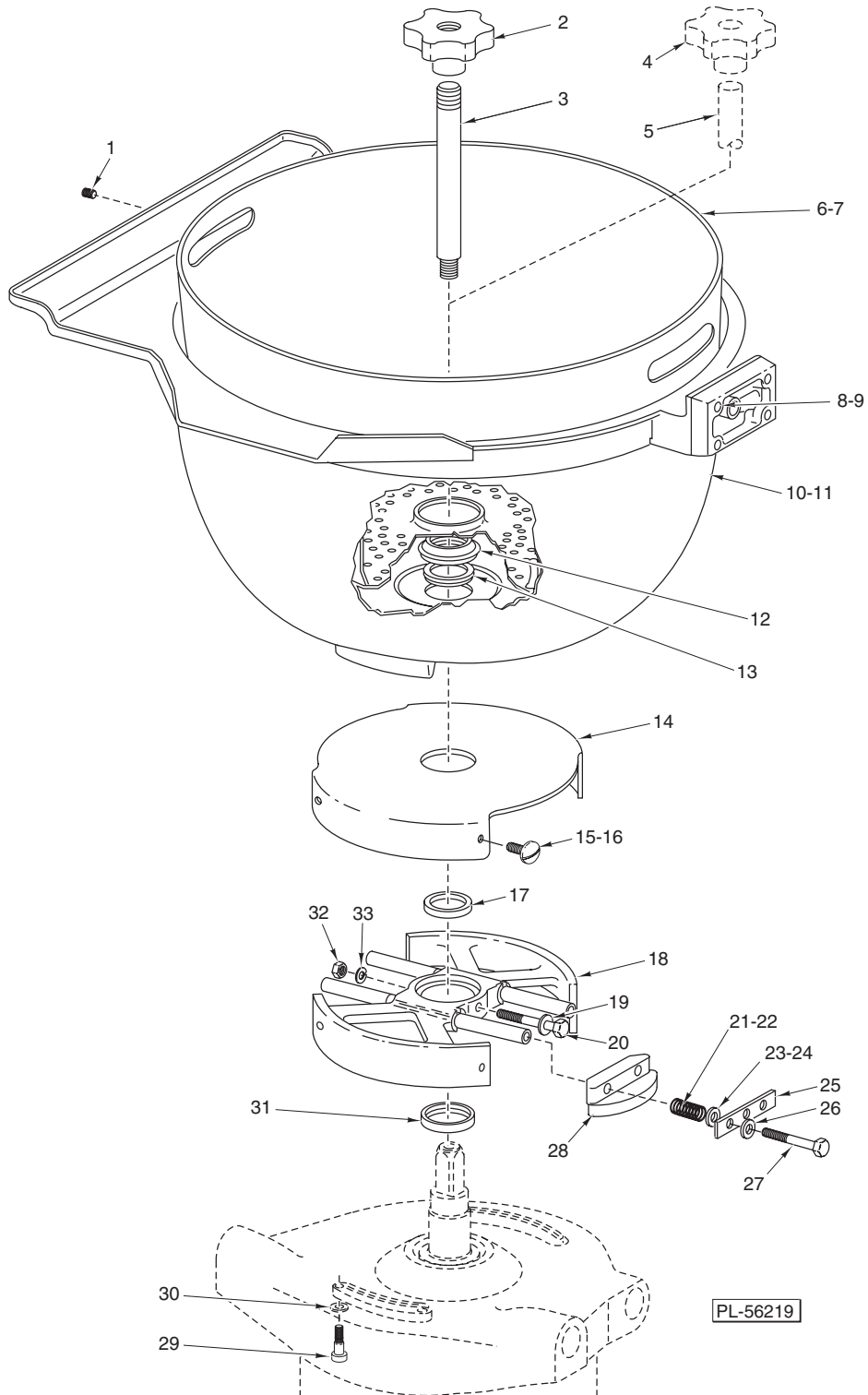

**BRAKE AND BOWL UNIT**

## BRAKE AND BOWL UNIT

ILLUS. PL-56219	PART NO.	NAME OF PART	AMT.
1	SC-055-01	Set Screw 10-24 x 1/4 Hex Soc. Hdls., Cup Pt. (SST) .....	1
2	00-291956	Knob – Retainer (Threaded) .....	1
3	00-274680	Shaft – Extension (Threaded) .....	1
4	00-122296	Knob – Retainer (Eccentric) .....	1
5	00-122293	Shaft – Extension (for Eccentric Knob) .....	1
6	00-122271	Strainer Basket Kit (HCM300) .....	1
7	00-292811	Strainer Basket Kit (HCM450) .....	1
8	00-122281	Pin – Lid Guide .....	1
9	NS-018-01	Jam Nut 1/4-20 Hex .....	1
10	00-122237	Bowl Assy. (HCM300) .....	1
11	00-122245	Bowl Assy. (HCM450) .....	1
12	00-122313	Retainer – Seal .....	1
13	00-123920	Seal – V-Ring .....	1
14	00-291113	Cover – Brake .....	1
15	SC-109-62	Mach. Screw 10-24 x 3/8 Slotted Pan Hd. (SST) .....	4
16	SC-121-94	Mach. Screw 10-24 x 3/8 Hex Button Hd. (SST) (ML-134071) .....	4
17	00-123920	Seal – V-Ring .....	1
18	00-435526	Brake Carrier Assy. ....	1
19	WL-008-22	Lockwasher 5/16 Internal Shakeproof .....	1
20	SC-109-75	Cap Screw 5/16-18 x 2 3/8 Hex Hd. ....	1
21	00-123095	Spring – Compression (60 Hz. Motor Only) .....	4
22	00-124953	Spring – Compression (50 Hz. Motor Only) .....	4
23	WS-018-30	Washer – Shim (25/64 I.D. x 1/16 Thk.) .....	AR
24	WS-029-35	Washer – Shim (25/64 I.D. x 1/32 Thk.) .....	AR
25	00-122170	Plate – Brace .....	2
26	WS-002-32	Washer (13/64 I.D.) .....	4
27	SC-110-31	Mach. Screw 10-24 x 3/4 Hex Hd. ....	4
28	00-436472	Brake Shoe & Lining Assy. ....	2
29	SC-089-35	Cap Screw 3/8-16 x 1 1/4 Soc. Fil. Hd. ....	4
30	WL-004-06	Lockwasher 3/8 Medium .....	4
31	00-122523	Seal – Shaft .....	1
32	NS-013-14	Nut 5/16-18 Hex .....	1
33	WL-003-47	Lockwasher 5/16 Medium .....	1

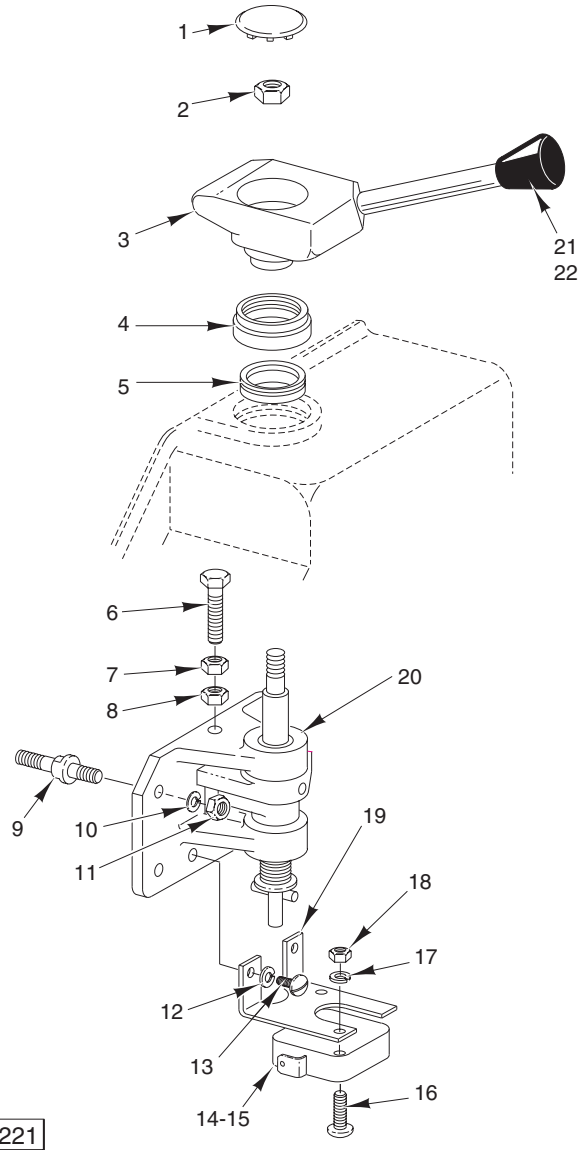

**HANDLE LOCK UNIT**



**HANDLE LOCK UNIT**

ILLUS.	PART NO.	NAME OF PART	AMT.
PL-56221			
1	00-290118	Plug – Hole .....	1
2	NS-036-19	Stop Nut <sup>5</sup> / <sub>16</sub> -18 Elastic .....	1
3	00-290595	Lock Handle Assy. ....	1
4	00-123221	Insert – Cover .....	1
5	00-123074-00005	Seal – V-Ring .....	1
6	SC-097-20	Cap Screw <sup>1</sup> / <sub>4</sub> -20 x 1 <sup>1</sup> / <sub>8</sub> Hex Hd. ....	1
7	NS-013-02	Nut <sup>1</sup> / <sub>4</sub> -20 Hex Fin. ....	1
8	NS-013-02	Nut <sup>1</sup> / <sub>4</sub> -20 Hex Fin. ....	1
9	00-290913	Stud .....	4
10	WL-003-47	Lockwasher <sup>5</sup> / <sub>16</sub> Medium .....	4
11	NS-013-14	Nut <sup>5</sup> / <sub>16</sub> -18 Hex Fin. ....	4
12	WL-004-40	Lockwasher #10 Medium .....	2
13	SC-008-09	Mach. Screw 10-24 x <sup>3</sup> / <sub>8</sub> Slotted Rd. Hd. ....	2
14	00-087711-154-1	Switch – Interlock .....	1
15	00-290059	Insulator .....	1
16	SC-081-05	Mach. Screw 4-40 x <sup>3</sup> / <sub>4</sub> Slotted Rd. Hd. ....	2
17	WL-003-03	Lockwasher #4 Medium .....	2
18	NS-009-45	Mach. Nut 4-40 Hex .....	2
19	00-124968	Bracket – Switch .....	1
*20	00-290606	Lock Shaft Assy. ....	1
21	00-123173	Knob .....	1
22	00-477102	Lock Handle Weldment (ML-134071) .....	1

\*This Assembly is Spring Loaded. Do Not Disassemble.

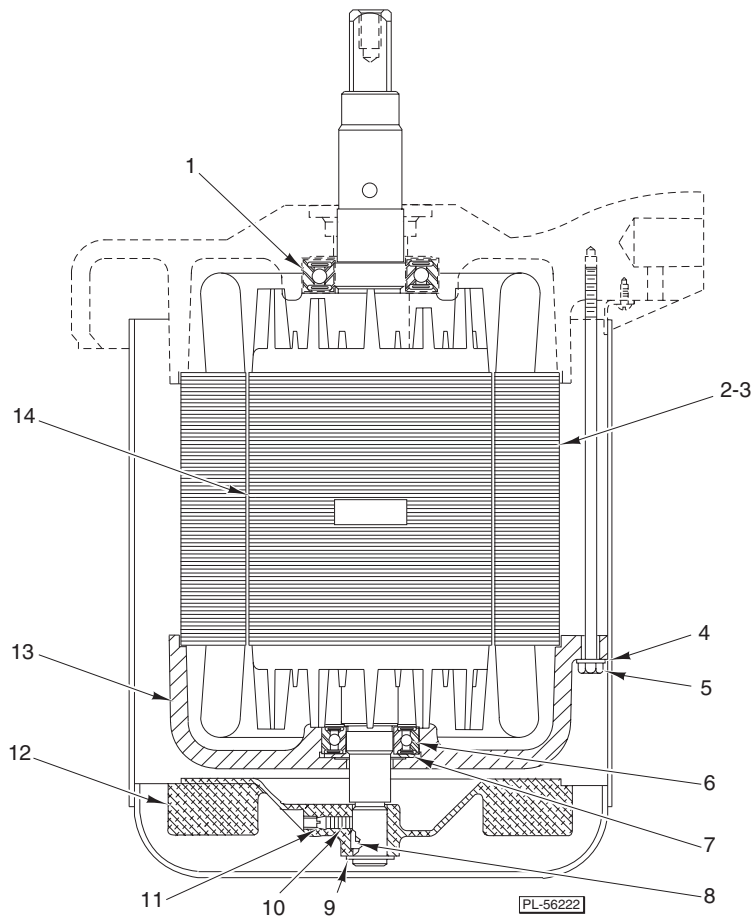

**MOTOR PARTS**

**MOTOR PARTS**

ILLUS.	PART NO.	NAME OF PART	AMT.
PL-56222			
1	BB-021-03	Ball Bearing #MRC207SZZ .....	1
2	00-065478-137-1	Stator Assy. (200 V., 60 Hz.) (5 Hp.) .....	1
3	00-065478-137-2	Stator Assy. (230/460 V., 60 Hz.) (5 Hp.) .....	1
4	WL-003-47	Lockwasher <sup>5</sup> / <sub>16</sub> Medium .....	3
5	00-122531-00001	Bolt – Special (5 Hp.) .....	3
6	BB-021-02	Ball Bearing – Fafnir #P205KDD .....	1
7	SL-005-01	Loading Spring – N.D. #52 Wavy .....	2
8	00-012430-00052	Key .....	1
9	RR-011-03	Retaining Ring .....	1
10	SC-075-11	Set Screw <sup>1</sup> / <sub>4</sub> -20 x <sup>5</sup> / <sub>8</sub> Soc. Hdls., Kn. Cup Pt. ....	1
11	SC-117-59	Set Screw <sup>1</sup> / <sub>4</sub> -20 x <sup>1</sup> / <sub>8</sub> Soc. Hdls., Flat Pt. ....	1
12	00-275183	Fan .....	1
13	00-122392	Bracket – Bearing .....	1
14	00-015747-00298	Rotor Assy. (5 Hp.) .....	1

