

BOX TO INCLUDE:
1EA 1.5" BASKET DRAIN

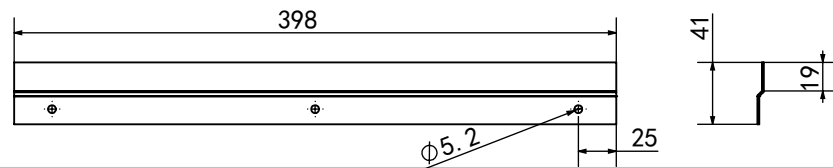
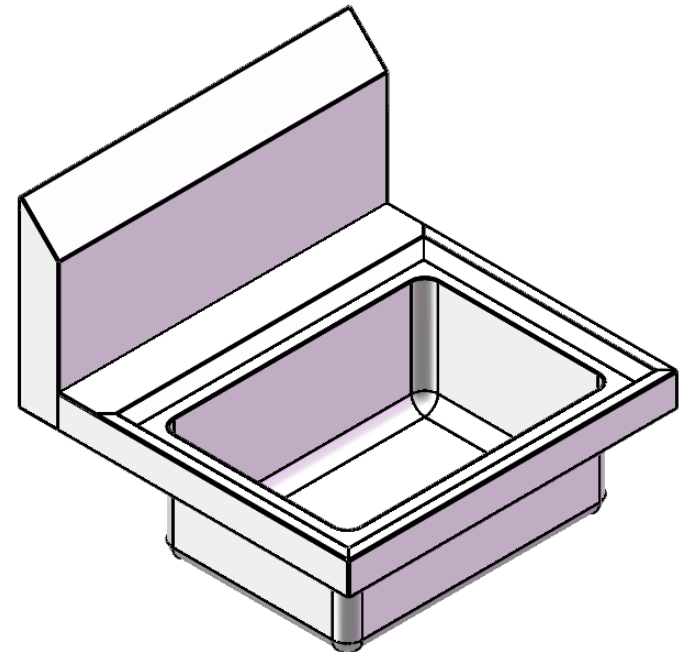

Item # : DH24
TWC # : 6058059
NSF # : SWHS-16
OA DIMS. 17"L X 17"W X 14"H(+/-X)
WEIGHT: *LBS(*KG)
MATERIAL: 20GA[1.0] 304
NSF CERTIFIED