

HOBART701 S Ridge Avenue, Troy, OH 45374
1-888-4HOBART • www.hobartcorp.com**H SERIES VACUUM
PACKAGING EQUIPMENT****HOBART****STANDARD FEATURES**

- Vacuum chamber size: 7.25" high x 16.75" x 19.56" long
- Up to three cycles per minute
- Quick-change, 16-in. seal bar
- Compact tabletop model saves valuable countertop space
- Simple operation and easy-to-use controls
- Ideal for small to medium size processors, restaurants and supermarkets
- Patented lid hinge system increases opening angle for easier product loading
- The heavy duty, 1.25 horsepower BUSCH 021 vacuum pump powers the Hobart HT120 for years of dependable service

MODEL

- HT120A – Analog Controls
- HT120GD – Digital Controls

Specifications, Details and Dimensions on Reverse Side.



HT120A



HT120GD

H SERIES VACUUM PACKAGING EQUIPMENT

H SERIES VACUUM PACKAGING EQUIPMENT



701 S Ridge Avenue, Troy, OH 45374
1-888-4HOBART • www.hobartcorp.com

SPECIFICATIONS

Length (A)	19.25"
Width (B)	25"
Maximum Height (C)	32.25"
Working Height (D)	14.875"
Seal Bar Length (E)	16"
Chamber Length (E)	19.56"
Chamber Width (F)	16.75"
Chamber Height (G)	7.25"
Between Seal Bar and Back of Chamber (H)	17.25"
Vacuum Pump	25m ³ /h (15cfm), 0.95 kW (1.25hp)
Net Weight	121 lbs.
Electrical Connection (Single Phase)	120V, 60Hz, 13 amps 220V, 50Hz, 6.5 amps
Capacity	20-30 seconds per cycle

DETAILS AND DIMENSIONS

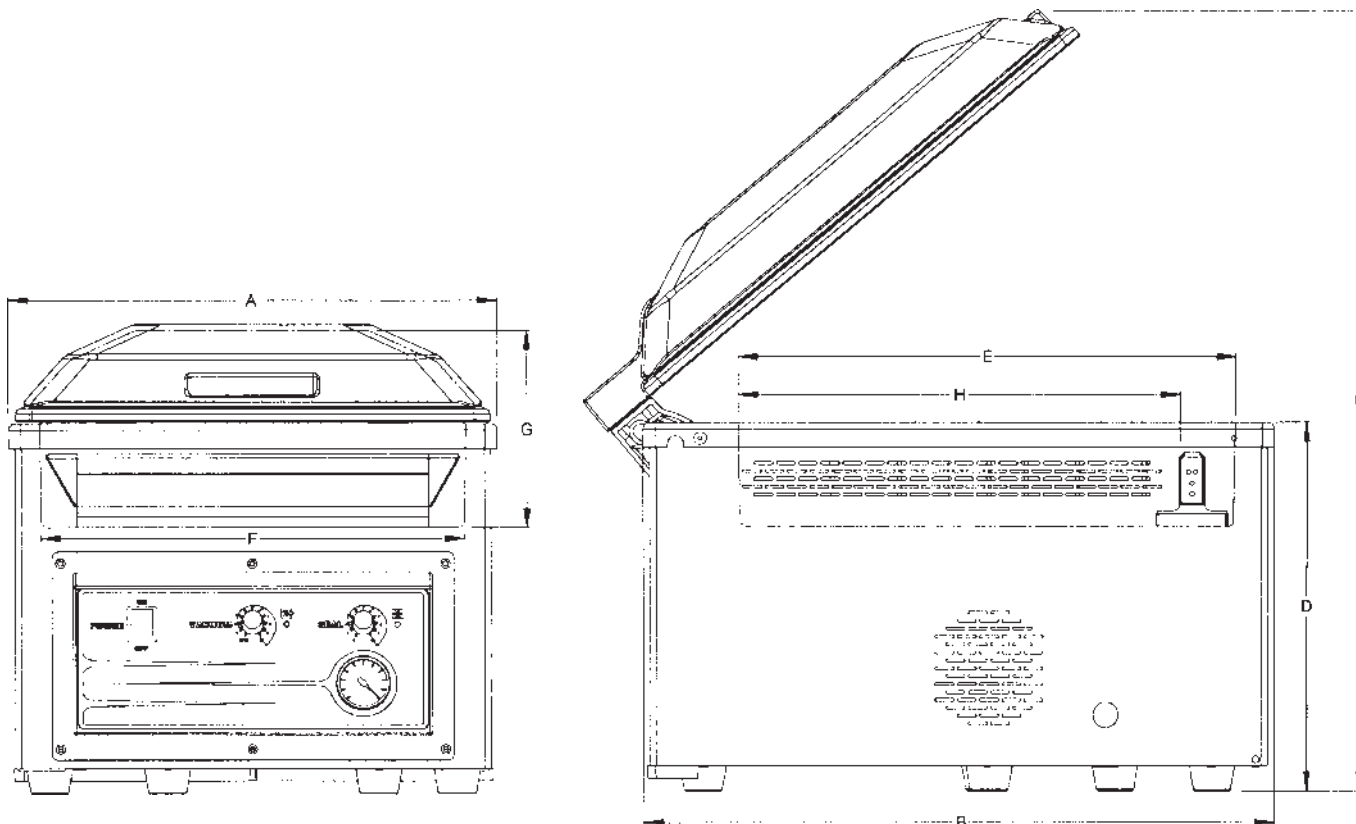

As continued product improvement is a policy of Hobart, specifications are subject to change without notice.