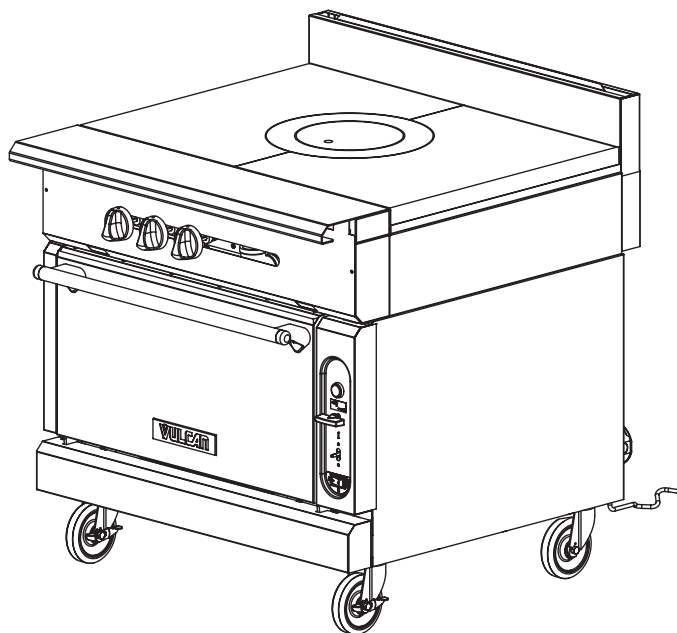

**VULCAN V SERIES HEAVY DUTY RANGES****VULCAN****HEAVY DUTY GAS RANGE**  
**RADIAL FIN FRENCH TOP / 36" WIDE GAS RANGE**

Model V1FT36S shown on a standard oven base

**SPECIFICATIONS**

36" wide heavy duty gas range, Vulcan model No. V1FT36 (modular), V1FT36B (cabinet base), V1FT36S (standard oven base) or V1FT36C (convection oven base). Modular construction for ease of installation. Stainless steel front, plate ledge, front top ledge with pull-out condiment rails, sides, base, exterior bottom, stub back and 6" adjustable legs on all "B", "S", & "C" models. Stainless steel extra deep crumb tray. Three cast ring burners totaling 45,000 BTU/hr. Individual pilots and controls for each burner. Heavy polished cast iron French plate. Standard oven: 50,000 BTU/hr. with porcelain oven bottom, sides, and interior door panel. Convection Oven: 32,000 BTU/hr. with porcelain oven bottom, sides, and interior door panel (115v-1 phase blower motor, 4 amps, 6' cord & plug). Ovens measure 27"w x 27"d x 13"h. Standard oven thermostats adjust from 150°-550°F. Convection oven adjusts from 175°-550°F and the optional finishing oven for standard ovens adjusts from 300°-650°F. Standard oven supplied with one rack, convection oven with two. Both ovens allow for three rack positions. Oven door is heavy duty with counter weight door hinges. 1-1/4" diameter front manifold and 1 1/4" rear gas connection, capped. Total input 45,000 BTU/hr.

**Exterior Dimensions:**

36 3/4"d x 36"w x 36"h on 6" adjustable legs



- V1FT36** Radial Fin French Top / Modular
- V1FT36B** Radial Fin French Top / Cabinet Base
- V1FT36S** Radial Fin French Top / Standard Oven
- V1FT36C** Radial Fin French Top / Convection Oven

**STANDARD FEATURES**

- Stainless steel front, front top ledge, burner box, sides, base, exterior bottom and stub back
- 1-1/4" diameter front gas manifold with 1-1/4" rear gas connection (*capped*)
- 45,000 BTU/hr. burners (*3 ring burner*)
- 50,000 BTU/hr. standard oven burner
- 32,000 BTU/hr. convection oven burner
- Porcelain oven cavity
- Individual pilots and controls for each burner
- Polished cast iron French Top
- 4" stainless steel stub riser
- 6" adjustable stainless steel legs for "S", "C", & "B" models (*no legs for modular model*)
- Stainless steel cabinet base doors
- One year limited parts and labor warranty

**OPTIONAL FEATURES (Factory Installed)**

- 1-1/4" rear gas connection
- Cap and cover front manifold
- Stainless steel oven cavity
- 650°F oven thermostat and steel hearth. ("*S*" models)
- Fan cooling package ("*C*" models)
- 4" adjustable flanged feet for modular models
- 6" adjustable flanged feet for "S", "C", & "B" models
- Less legs for dolly mounting of "S", "C", & "B" models
- Set of 4 casters, 6" high (*two locking*)
- 3" high toe base for curb mounting
- 3/4", 1", or 1 1/4" gas pressure regulator (*specify gas type – pack loose*)
- Common condiment type, telescoping plate rails

**ACCESSORIES (Packaged & Sold Separately)**

- Extra removable shelves for use with Universal rack guides (*cabinet base*)
- Banking strip
- Common condiment type, telescoping plate rails (*starting at 24" length*)
- 10", 22", or 34" high back risers (*no shelf*)
- 22" single deck solid or flo-thru high shelf risers
- 34" double deck solid or flo-thru high shelf risers
- Dolly frames
- Flexible gas hose with quick disconnect & restraining device

**VULCAN****Vulcan & Wolf Range**

a division of ITW Food Equipment Group LLC

P.O. Box 696 ■ Louisville, KY 40201 ■ Toll-free: 1-800-814-2028 ■ Local: 502-778-2791 ■ Quote &amp; Order Fax: 1-800-444-0602

# VULCAN V SERIES HEAVY DUTY RANGES



## HEAVY DUTY GAS RANGE RADIAL FIN FRENCH TOP / 36" WIDE GAS RANGE

### INSTALLATION INSTRUCTIONS

1. A properly sized gas pressure regulator suitable for battery or single unit application must be furnished and installed. Natural gas 6.0" W.C., propane gas 10 W.C.
2. An adequate ventilation system is required for commercial cooking equipment. Information may be obtained by writing to the National Fire Protection Association, 1 Batterymarch Park, Quincy, MA 02269, www.NFPA.org. When writing, refer to NFPA No. 96.
3. These units are manufactured for installation in accordance with ANSZ223.1A (latest edition), National Fuel Gas Code. Copies may be obtained from The American Gas Association, 400 N Capitol St. NW, Washington, DC 20001, www.AGA.org.

4. Clearances	Rear	Sides
Combustible	10"	10"
Non-combustible	0"	0"

5. For proper combustion, install equipment on adjustable legs or casters. On curb or platform, allow 3-1/2" front overhand. Toe base with leveling bolts are required for curb installation. Specify when ordering.
6. Cannot be battered with GH series equipment.
7. This appliance is manufactured for commercial installation only and is not intended for home use.

**NOTE: In line with its policy to continually improve its product, Vulcan reserves the right to change materials and specifications without notice.**

Specify type of gas when ordering. Specify altitude when above 2,000 feet.

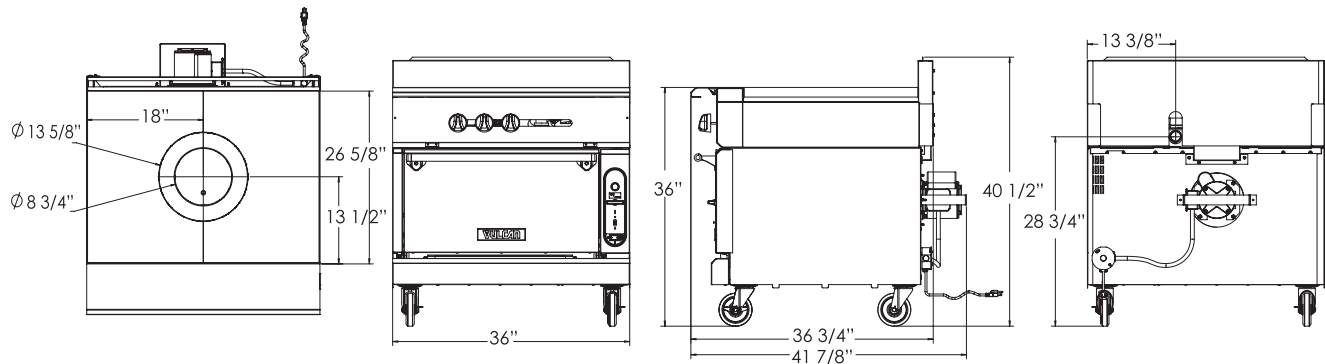

TOP CONFIGURATION	MODEL NUMBER	DESCRIPTION	TOTAL INPUT BTU / HR	SHIPPING WEIGHT LBS / KG
	V1FT36	Radial Fin French Top / Modular	45,000	404 / 183
	V1FT36B	Radial Fin French Top / Cabinet Base	45,000	504 / 229
	V1FT36S	Radial Fin French Top / Standard Oven Base	95,000	685 / 311
	V1FT36C	Radial Fin French Top / Convection Oven Base	77,000	763 / 346



**Vulcan & Wolf Range**  
a division of ITW Food Equipment Group LLC

P.O. Box 696 ■ Louisville, KY 40201 ■ Toll-free: 1-800-814-2028 ■ Local: 502-778-2791 ■ Quote & Order Fax: 1-800-444-0602