

INSTRUCTIONS

CLe-SERIES DISHWASHERS

MODEL	R-L OPERATION	L-R OPERATION
CL44e	ML-138101	ML-138102
CLPS66e	ML-138103	ML-138104
CLCS66e	ML-138109	ML-138110
CL54e	ML-138105	ML-138106
CLPS76e	ML-138107	ML-138108
CLCS76e	ML-138111	ML-138112
CL64e	ML-138174	ML-138175
CLPS86e	ML-138176	ML-138177
CLCS86e	ML-138178	ML-138179

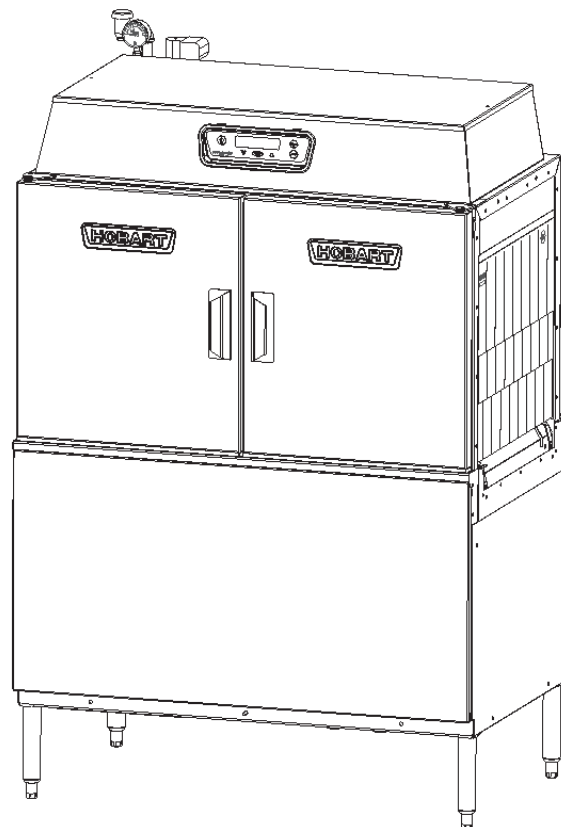

HOBART

701 S. RIDGE AVENUE
TROY, OHIO 45374-0001

937 332-3000

www.hobartcorp.com

F44126 Rev. A (November 2008)

IMPORTANT FOR YOUR SAFETY

THIS MANUAL HAS BEEN PREPARED FOR PERSONNEL QUALIFIED TO INSTALL GAS EQUIPMENT, WHO SHOULD PERFORM THE INITIAL FIELD START-UP AND ADJUSTMENTS OF THE EQUIPMENT COVERED BY THIS MANUAL.

POST IN A PROMINENT LOCATION THE INSTRUCTIONS TO BE FOLLOWED IN THE EVENT THE SMELL OF GAS IS DETECTED. THIS INFORMATION CAN BE OBTAINED FROM THE LOCAL GAS SUPPLIER.

IMPORTANT

IN THE EVENT A GAS ODOR IS DETECTED, SHUT DOWN UNITS AT MAIN SHUTOFF VALVE AND CONTACT THE LOCAL GAS COMPANY OR GAS SUPPLIER FOR SERVICE.

FOR YOUR SAFETY

DO NOT STORE OR USE GASOLINE OR OTHER FLAMMABLE VAPORS OR LIQUIDS IN THE VICINITY OF THIS OR ANY OTHER APPLIANCE.

FOR YOUR SAFETY READ BEFORE OPERATING

DO NOT USE THIS APPLIANCE IF ANY PART HAS BEEN UNDER WATER. IMMEDIATELY CALL A QUALIFIED SERVICE TECHNICIAN TO INSPECT THE APPLIANCE AND TO REPLACE ANY PART OF THE CONTROL SYSTEM AND ANY GAS CONTROL WHICH HAS BEEN UNDER WATER.

IN THE EVENT OF A POWER FAILURE, DO NOT ATTEMPT TO OPERATE THIS DEVICE.

TABLE OF CONTENTS

GENERAL	4
Chemical Sanitizing	4
INSTALLATION	5
Unpacking	5
Installation Codes	5
Adjust Machine Height and Level Machine	5
Dish Table Assembly	5
Water Requirements	6
Plumbing Connections	6
Drain Connection	6
Fill & Final Rinse Connection	7
Chemical Feeder Installations	7
Steam Connection (When Equipped for Steam Heat)	8
Gas Connection (When Equipped for Gas Heat)	8
Venting Requirements	9
Type II Canopy Hood	9
Pant-Leg Vent Connections	10
Exhaust Flow Requirements	11
Electrical Connections – Dishwasher	12
Optional Equipment Control Connections	13
OPERATION	14
Preparation	14
Curtain Installation	15
Keypad and Display	17
Filling the Dishwasher	17
Starting the Gas Heat Dishwasher	17
Minimum Temperatures	18
High-Temperature Operation	18
Low-Temperature Operation	18
Alternative Temperature Display Names	18
Low FR Temp Alert	18
Tank Temperature Alert	18
Dishwashing	19
Optional Table Limit Switch	20
Auto-Timer	20
Energy Saver Mode	20
Dirty Water Mode	20
CLEANING	20
Deliming Recommendations	22
DOs and DON'Ts for Your New Hobart Warewasher	23
PROGRAMMING	24
Programming Security Levels	24
Programming Instructions	25
Menu Display Prompts	25
Entering the Parameters Menu	26
Navigating the Parameters Menu	26
Parameters Menu	27
Communications Setup Menu	28
MAINTENANCE	28
Vent	28
Lubrication	28
Service	28
TROUBLESHOOTING	29

Installation, Operation and Care Of CL_e-SERIES DISHWASHERS

SAVE THESE INSTRUCTIONS

GENERAL

CL_e is a rack-type warewashers that moves the racks from one end of the machine to the other, exposing the ware to progressive wash and rinse zones. (Pumps and final rinse are activated by the inserted rack to energize the specific wash or rinse action needed.) The CL_e-series machines are offered in optional lengths, sections, features, and provide different speeds to meet productivity and performance requirements. (All CL_e-Series Dishwashers have electronic controls with digital temperature displays.)

Tanks, chambers, frames, legs and adjustable feet are made of welded stainless steel construction. Hinged inspection doors provide access to the interior wash and rinse zones. CLPS models provide a 22-inch power scrapper section and hinged access door. The power scrapper removes the heavy soil before the rack enters the wash zone.

Machines can be ordered as left-to-right or right-to-left operation. Either electric, gas, or steam tank heat was specified at time of order. Machines come standard ready to operate with high-temperature sanitizing mode.

Hobart offers three right-angle possibilities to put your machine in a corner installation:

- The Side Loader moves the rack at a right angle into the machine from the scrapping area.
- The Direct Drive Unloader moves the rack at a right angle coming out of the machine to tabling where the clean ware can be unracked.
- The Corner Scrapper (CLCS models) puts a Power Scrapper in the corner location at the load end of your machine, combining right angle entry with a scrapper section.

CHEMICAL SANITIZING

Machines can be converted to operate with low-temperature sanitizing mode (with the use of chemical sanitizers). Refer to Sanitizing Mode programming instructions on page 27.

Hot water sanitizing mode is designated by "High Temp." on the display when the machine is turned on. Low-temperature or chemical sanitizing mode is designated by "Low Temp." on the display when the machine is turned on.

CL_e models that operate with chemical sanitization, use incoming water and final rinse water at 120°F minimum. Tank heaters raise that temperature to 130°F for wash (and power rinse, if equipped).

INSTALLATION

UNPACKING

Immediately after unpacking the dishwasher, check for possible shipping damage. If the machine is found to be damaged, save the packaging material and contact the carrier within 15 days of delivery.

Prior to installation, verify that the electrical service agrees with the specifications on the machine data plate, which is located on the left-hand side of the control box.

After unpacking the dishwasher, remove the items shipped loose (overflow tube or standpipe, splash shields, curtains and literature envelope with instructions and chamber hole plug kit) from inside the dishwasher.

INSTALLATION CODES

Installation must be in accordance with state and local codes, or in the absence of local codes, with the National Fuel Gas Code, ANSI Z223.1 (latest edition), if applicable, and the National Electrical Code ANSI / NFPA 70 (latest edition). In Canada, the installation standards are: CAN/CSA B149.1 and CSA C22.1 (latest editions).

ADJUST MACHINE HEIGHT AND LEVEL MACHINE

Set the dishwasher in its proper location. Adjust the height and level the machine by turning the adjustable feet in or out as necessary.

DISH TABLE ASSEMBLY

Dish tables should be fitted into the dishwasher (Figs. 1, 2 & 3). Use silicone sealant between table and lip of tank to prevent leakage. Rack track height should be from $\frac{1}{4}$ " to $\frac{5}{16}$ " (Fig. 2) above the tank lip. Dish tables should be sloped so that any water carried from the dishwasher will drain back into the machine, but not from the scrapping area.

NOTE: The dishwasher must be in its final position, adjusted for proper height and properly leveled before table assembly and plumbing connections are made.

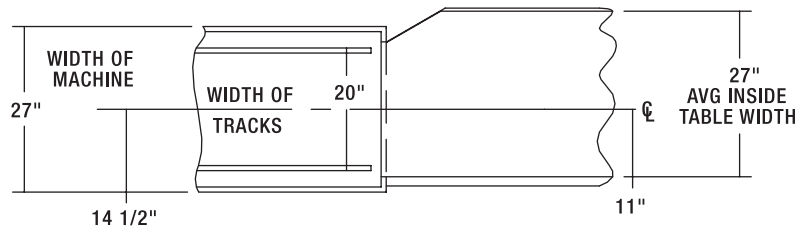

SUGGESTED TRACK AND TABLE LAYOUT

Fig. 1

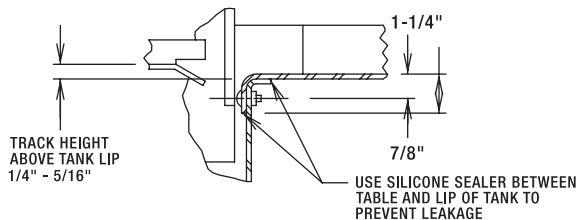

SECTIONAL VIEW SHOWING TABLE CONNECTIONS

Fig. 2

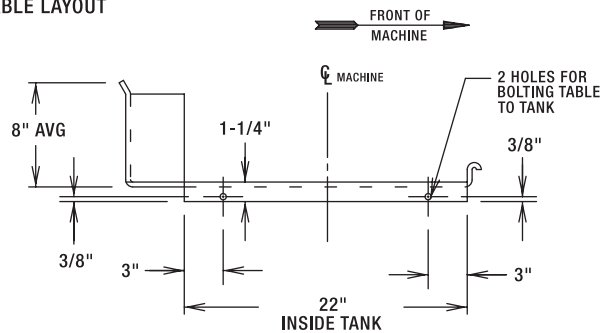

VIEW SHOWING HOLE LOCATIONS IN TURNED DOWN PORTION OF TABLE

Fig. 3

WATER REQUIREMENTS

Proper water quality can improve ware washing performance by reducing spotting, enhancing effectiveness of labor and extending equipment life. Water conditions vary from one location to another. The recommended proper water treatment for effective and efficient use of this equipment will also vary depending on the local water conditions. Ask your municipal water supplier for details about local water specifics prior to installation.

Recommended water hardness is 3 grains of hardness per gallon or less. Chlorides must not exceed 50 parts per million. Water hardness above 3 grains per gallon should be treated by a water conditioner (water softener or in-line treatment). Water treatment has been shown to reduce costs associated with machine cleaning, reduce deliming of the dishwasher and reduce detergent usage in the dishwasher.

Sediment, silica, chlorides or other dissolved solids may require particulate filtration or other water treatment.

If an inspection of the dishwasher or booster heater reveals lime buildup after the equipment has been in service, in-line water treatment is recommended. Contact your local Hobart Service office for specific recommendations.

PLUMBING CONNECTIONS

⚠ WARNING Plumbing connections must comply with applicable sanitary, safety and plumbing codes.

The plumber who connects this machine is responsible for making certain that both water and steam lines are THOROUGHLY FLUSHED OUT BEFORE connecting to any manual valve or solenoid valve.

This “flush-out” is necessary to remove all foreign matter, such as chips (resulting from cutting or threading of pipes), pipe joint compound from the lines or, if soldered fittings are used, bits of solder or cuttings from the tubing. Debris, if not removed, may lodge in the valves and render them inoperative. Manual valves or solenoid valves found defective by foreign matter and any expenses resulting from this debris are NOT the responsibility of the manufacturer.

DRAIN CONNECTION

The common drain for the tank(s) requires only one connection to the floor drain. The drain can be connected at either end. A pipe plug is provided for the opposite end. Connect the drain (Fig. 4) through a trap to the sewer using 2" NPT pipe. If a grease trap is required by code, it should have a minimum flow capacity of 31 gallons per minute.



Fig. 4

FILL & FINAL RINSE CONNECTION

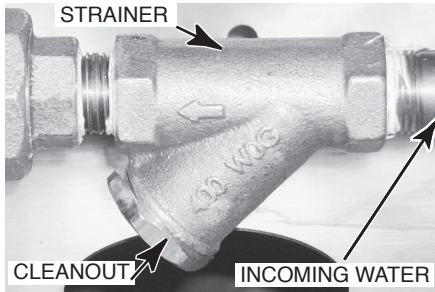

Fig. 5

Use 1/2" minimum I.D. pipe size for the incoming water supply line to the machine (Fig. 5). A flowing pressure of 15 to 25 psig must be maintained at the machine. For long runs, use larger pipe and insulation to ensure adequate pressure and temperature. If flow pressure exceeds 25 psig, a pressure-reducing valve (by others) must be installed in the water supply line.

For temperature requirements, refer to the Required Incoming Water Temperature table on this page.

REQUIRED INCOMING WATER TEMPERATURE

HOT WATER SANITIZATION			CHEMICAL SANITIZATION
No Booster	15 KW Booster 6 Wires Connect to Booster	30 KW Booster 12 Wires Connect to Booster	
180°F Minimum	140°F Minimum	110°F Minimum	120°F Minimum

NOTICE The water pressure regulator must have a relief bypass. Failure to use the proper type of pressure regulator may result in damage to the machine.

A pressure gauge is provided for verification of proper water pressure.

CHEMICAL FEEDER INSTALLATIONS

This machine must be operated with an automatic detergent feeder and, if applicable, an automatic chemical sanitizer feeder, including a visual means to verify that detergents and sanitizers are delivered or a visual or audible alarm to signal if detergents and sanitizers are not available for delivery to the respective washing and sanitizing systems. Chemical feeders are supplied by others. For electrical connection, refer to Optional Equipment Control Connections, page 13.



Fig. 6

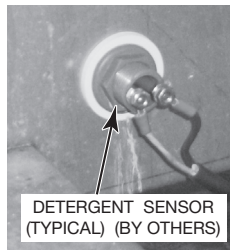

Fig. 7

Detergent Feeder

Your chemical supplier will install a detergent feeder port similar to the one shown in Fig. 6, that provides for discharge of detergent into the wash tank.

An electric monitoring device, similar to the one shown in Fig. 7, will be installed on the side of the wash tank to signal the feeder to maintain the proper concentration of detergent.

Rinse Agent Feeder

Rinse agent is typically fed into the final rinse water at one of the ports on the incoming water line below the pressure gauge (Fig. 8).

Chemical Sanitizer Feeder

Chemical sanitizer (on machines using low-temperature sanitizing) is fed into the final rinse water line at the other port on the incoming water line below the pressure gauge (Fig. 8).

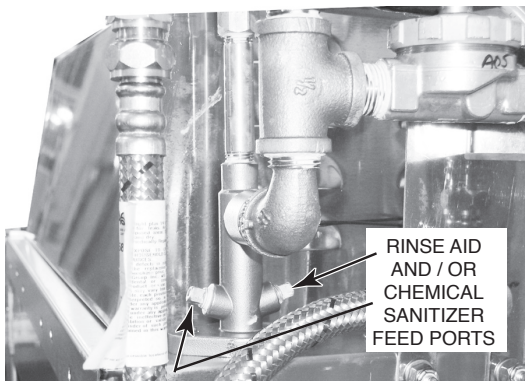

Fig. 8

STEAM CONNECTION (When Machine is Equipped with Steam Tank Heat)

NOTICE Steam supply pressure must agree with the steam trap (supplied) which is rated for 10 to 50 psig differential pressure. If flowing pressure exceeds 50 psig, a pressure regulator (by others) must be installed in the supply line. Steam flow is controlled by solenoid valves.

For single-tank steam coil installations, two connections are required, one for supply and one for return. For two-tank steam coil installations, one common supply connection and two return connections are required.

GAS CONNECTION (When Machine is Equipped with Gas Tank Heat)

Check the gas data plate attached to the dishwasher on the side of the control box or refer to the tag attached to the gas burner tubing for the type of gas to be used. All machines are shipped configured for natural gas. If conversion to LP gas (propane) is required, a conversion kit with instructions is supplied and must be installed before the machine is operated.

The burner is not adjustable. If flowing gas pressure is above 7" W.C. (natural gas) or 11" W.C. (propane gas), an additional regulator valve (by others) must be installed in the supply line. Static incoming line pressure should not exceed 14.0" W.C. for either propane or natural gas.

⚠ WARNING The gas supply line to the dishwasher must be provided with a shut-off valve per code. The appliance and its gas connections must be leak tested before placing the appliance in operation. Use soapy water for leak tests. DO NOT use an open flame.

The installation must conform with local codes, or in the absence of local codes, with the National Fuel Gas Code, ANSI Z223.1 (latest edition), available from the American Gas Association, Inc., 1515 Wilson Blvd., Arlington, VA 22209. In Canada, comply with CAN/CSA B149.1 and CSA C22.1 (latest editions).

NOTE: For gas line pipe connections, use Loctite 565, Hobart part number 546292, or a flexible sealant suitable for use with Natural and Propane Gases.

- The appliance and its individual shutoff valve must be disconnected from the gas supply piping system during any pressure testing of that system at test pressures in excess of 1/2 psig (3.45 kPa).
- The appliance must be isolated from the gas supply piping system by closing its individual manual shutoff valve during any pressure testing of the gas supply piping system at test pressures equal to or less than 1/2 psig (3.45 kPa).

GAS SPECIFICATIONS

Models	Type of Gas	BTU/Hr	Connection Line Size	Flowing Gas Pressure - Not Static Inches W.C. (Water Column)		
				Incoming Line Pressure		Manifold Pressure
				Minimum	Maximum	
CL44e, CLPS66e, CLCS66e CL54e, CLPS76e, CLCS76e	Natural Propane	78,000 78,000	1/2" NPT 1/2" NPT	3.5" W.C. 9.0" W.C.	7.0" W.C. 11.0" W.C.	3.2" W.C. 8.2" W.C.
CL64e, CLPS86e, CLCS86e	Natural Propane	156,000 156,000	3/4" NPT 3/4" NPT	3.5" W.C. 9.0" W.C.	7.0" W.C. 11.0" W.C.	3.2" W.C. 8.2" W.C.

Dissipate test pressure from the gas supply line before reconnecting the appliance and its manual shutoff valve to the gas supply line.

NOTICE Failure to follow this procedure may damage the gas valve.

▲ WARNING Gas heat machines must be provided with a means to exhaust the flue gases to the exterior of the building.

Refer to Venting Requirements on pages 9 – 11.

The dishwasher must be installed so that the flow of combustion and ventilation air will not be obstructed. Ensure that no electrical cables or plumbing are routed over the gas flue area. Adequate clearances for air openings into the combustion chamber must be provided. Make sure there is an adequate supply of make-up air in the room to allow for combustion of the gas at the burner(s).

Keep the appliance area free and clear from all combustible substances. Do not obstruct the flow of combustion and ventilation air. The dishwasher must have a minimum clearance from combustible construction of 3" at the rear and 0" at the sides. A clearance of 23" must be provided at the front and 20" at each end of the dishwasher for servicing and proper operation.

The burner is ignited automatically by solid-state electronic circuitry. There is no pilot light. Gas flow is regulated by the temperature control circuit.

VENTING REQUIREMENTS

Type II Canopy Hood

Most commercial dishwashers must be provided with external venting per local codes. The exception is electric or steam heat machines operating in the chemical or low temperature sanitizing mode where the existing room ventilation will compensate for the vapors produced. The local authority has final jurisdiction over this matter.

Venting can be provided by either a canopy hood over the whole machine (Fig. 9) or by the pant-leg duct connection (Fig. 10).

A Hobart CLe-Series dishwasher equipped for gas tank heat is not provided with a flue collar and is not intended to have the flue directly connected to a ventilation system. However, the products of combustion must be vented to the outside air. Exhaust air must not be vented into a wall, a ceiling, or a concealed space of a building. A vent hood over the entire dishwasher (Fig. 9) can be employed to vent both the moist air from the dishwashing chamber and the flue gases from the gas heater. The volume of flue exhaust required for venting moist air and flue gases using a single vent hood over the entire dishwasher must be calculated using the Exhaust Flow Requirements on page 11.

A Type II canopy hood is recommended. A factory-built commercial exhaust hood may be listed as conforming to Underwriters Laboratory's Standard 710 titled, *Exhaust Hoods for Commercial Cooking Equipment*. Hoods must be installed according to the manufacturer's instructions. Makeup air must be provided so that the exhaust flow rate results in a positive building pressure in the room where the unit is located (more outside air than exhaust air). Factory-built hoods not tested to UL Standard 710 and custom built hoods must comply with the following specifications: They must be built from stainless steel, 0.037" [No. 20 Gage] minimum thickness, or copper sheet weighing at least 24 ounces per square foot; the hood must be secured in place by noncombustible supports and the hood must meet the Exhaust Flow Requirements on page 11.

TYPE II CANOPY HOOD

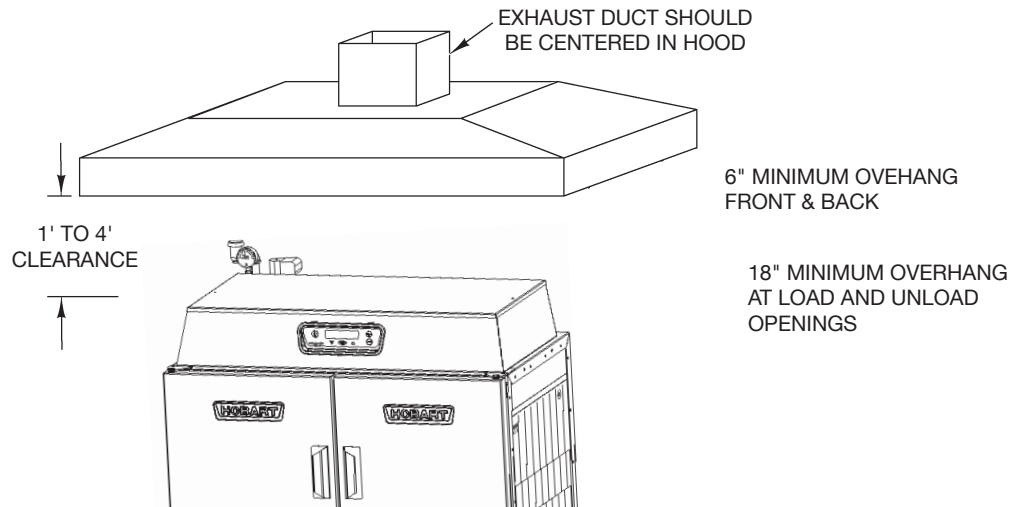

Fig. 9

Pant-Leg Vent Connections

⚠ WARNING Gas heat machines must be provided with a means to exhaust the flue gases to the exterior of the building.

Pant-Leg duct connectors (Fig. 10) alone DO NOT provide ventilation for the gas flue at the rear of the machine. A mini-vent hood (Fig. 11) must be used or a canopy type hood may be used (Fig. 9).

Moist air escapes from each end of the conveyor type dishwasher. The recommended exhaust requirement is 200 CFM at the entrance end of the dishwasher and 400 CFM at the discharge end. Optional vent hoods or extended hoods may be provided at each end of the machine. Sufficient make-up air must be provided so the exhaust flow results in a positive building pressure in the room in which the unit is located (more outside air than exhaust air). Hoods are provided with 4" x 16" vent connectors with vent dampers which allow adjustment during installation. Typical construction is for 'Pant-Leg' hood connections to the 4" x 16" vent connectors (Fig. 10). Vent stacks must be watertight and fit inside the vent connector openings.

If using the 'Pant-Leg' duct, a mini-vent hood (Fig. 11) must be used to vent the flue gases on machines using gas heat. The mini-vent hood must be positioned a minimum of 18" above the flue exit at the rear of the dishwasher and connected to existing duct work. The volume of flue exhaust in the mini-vent hood should not exceed 200 CFM.

In either case, if a powered means of exhaust is used, an electrical interlock must be provided to allow the flow of gas to the dishwasher burner only when the exhaust system is in operation.

For more information, refer to the National Fuel Gas Code, ANSI Z223.1, NFPA54. In all cases, local codes will prevail.

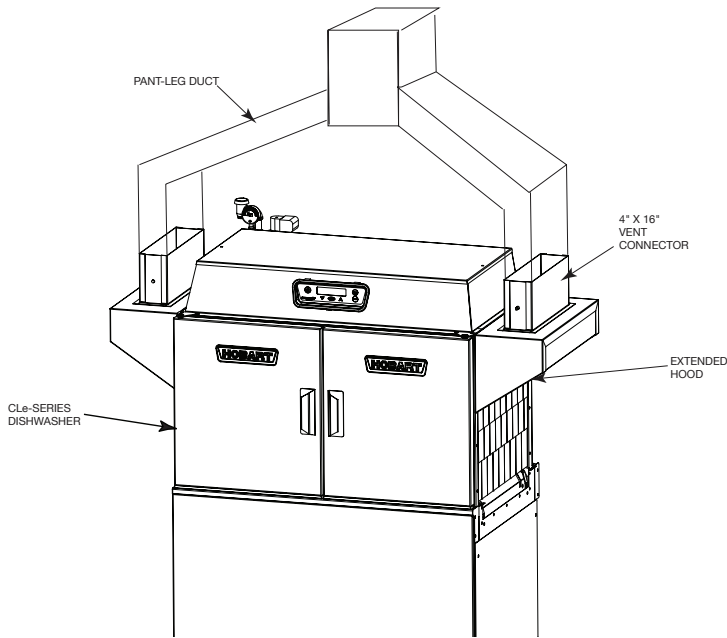

Fig. 10

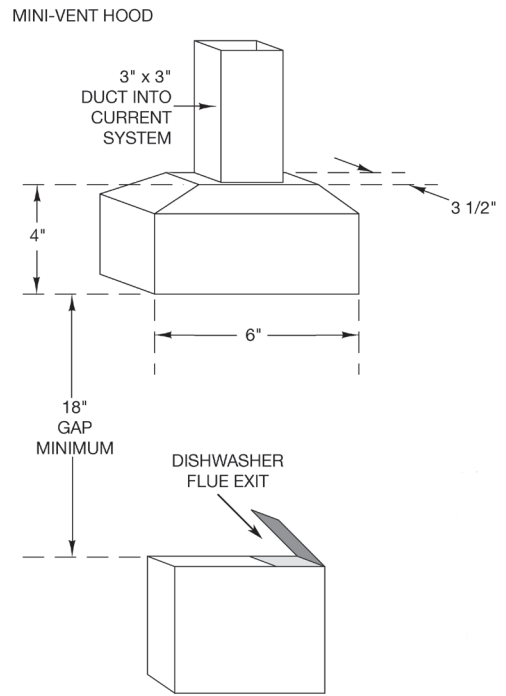

Fig. 11

Exhaust Flow Requirements

The following is based on the 2006 International Mechanical Code (IMC):

The flow of air required for a vent hood is based on the linear length of the face of the hood, measured along the front side, parallel with the front of the appliance (refer to LENGTH in Fig. 12). The minimum net air flow for Type II hoods used with dishwashers is 100 CFM per linear foot of hood length. Simply multiply the hood's length, in feet, times 100 CFM to obtain the required flow rate.

Subtract make-up air flow supplied directly to a hood cavity, from the total exhaust flow rate of the hood, if applicable.

For hood designs not covered by these calculations consult the latest edition of the IMC or other local codes.

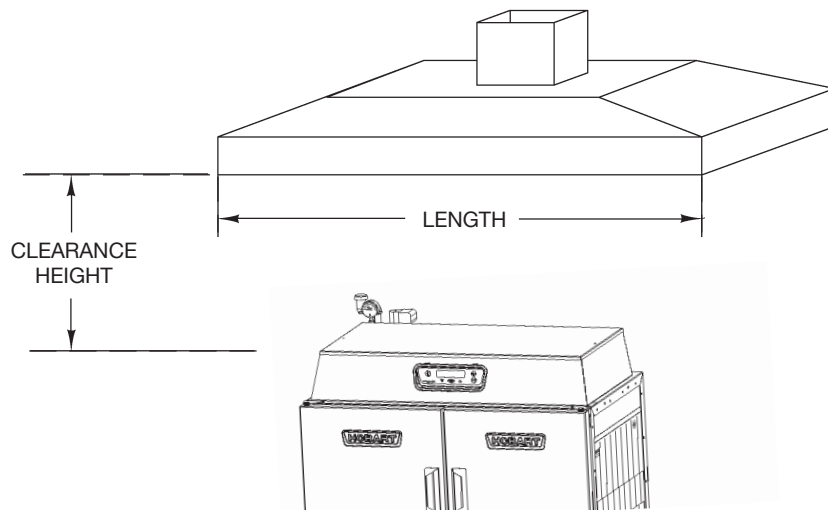

Fig. 12

ELECTRICAL CONNECTIONS — DISHWASHER

⚠ WARNING Electrical and grounding connections must comply with the applicable portions of the National Electrical Code, ANSI/NFPA 70, latest edition, and/or other local electrical codes.

⚠ WARNING Disconnect the electrical power to the machine and follow lockout/tagout procedures. There may be multiple circuits. Be sure all circuits are disconnected.

Connect a permanent electrical power supply to the terminal block in the control box on top of the machine. Refer to the machine data plate for proper connection information and the electrical diagram located inside the control box cover.

Single-Point Electrical Connection (S.P.E.C.) — Three-Phase Only

All three-phase machines are prewired for single-point electrical connection for the motors, controls and electric tank heaters; however, electric tank heat machines (three-phase only) may be field wired for separate electrical connections. Refer to the wiring diagram inside the control box lid. **NOTE:** The booster heater, when supplied, is always provided with a separate electrical connection.

Motor Rotation — Three-Phase Only

NOTICE Before placing a three-phase machine into service, check to verify that the conveyor motor rotates in the correct direction. (The control box is pre-wired at the factory so that all motors are phased together. If the conveyor motor rotation is correct, the pump motors will also be correct.) Incorrect rotation will result in unacceptable performance.

To check the conveyor motor's rotation:

Close the machine doors, press POWER on the keypad and allow the machine to fill. When the machine is completely filled, press POWER to turn the machine off.

⚠ WARNING Disconnect the electrical power to the machine and follow lockout/tagout procedures. There may be multiple circuits. Be sure all circuits are disconnected.

Remove the front panel below the doors. Reconnect the electrical power to the machine, being careful not to touch any uninsulated electrical parts exposed by removing the front panel. Press START / ENTER on the keypad and verify proper motor rotation, as follows:

The conveyor motor and clutch must rotate counterclockwise for machines with right-to-left operation, and clockwise for machines with left-to-right operation. If correct, the conveyor dog will always push slowly toward the exit end of the machine and will retract quickly toward the entrance end.

If the rotation of the conveyor motor is correct, press POWER to turn the machine off. Disconnect electrical power to the machine, and replace the front panel.

If the conveyor motor does not rotate in the proper direction, disconnect the electrical power to the machine. At the machine control box on top of the machine, reverse any two of the incoming power supply leads, either the leads to the entire machine, or the leads to the motor and controls if they are wired independent of the heaters. Do not simply reverse the leads to the conveyor motor.

Reconnect the electrical power to the machine. Re-check the conveyor motor's rotation. The conveyor motor and clutch must rotate counterclockwise for machines with right-to-left operation, and clockwise for machines with left-to-right operation.

If the rotation of the conveyor motor is correct, press POWER to turn the machine off. Disconnect the electrical power to the machine. Replace the top cover to the control box, and replace the front panel below the doors.

OPTIONAL EQUIPMENT CONTROL CONNECTIONS

⚠ WARNING Electrical and grounding connections must comply with the applicable portions of the National Electrical Code, NFPA 70 (latest edition) and / or other local electrical codes.

⚠ WARNING Disconnect the electrical power to the machine and follow lockout / tagout procedures. There may be multiple circuits. Be sure all circuits are disconnected.

Detergent Feeder

The maximum rating for a detergent dispenser connected to DPS1 and DPS2 is 1.5 amps at line voltage. Refer to Chemical Feeder Installations, page 7.

Rinse Aid Feeder and / or Chemical Sanitizer Feeder

The maximum rating for a rinse aid dispenser and / or chemical sanitizer feeder connected to RPS1 and RPS2 is 1.5 amps at line voltage. Refer to Chemical Feeder Installations, page 7.

Vent Fan Control

The maximum rating for a vent fan control connected to VFC1 and VFC2 is 1.5 amps, pilot duty.

OPERATION

PREPARATION

Make sure the dishwasher is clean and all parts are in place.

If Equipped with Scrapper (PS/CS)

Install the standpipe in the scrapper tank (Fig. 13). Standpipe with strainer (Fig. 13) goes in the first tank where the rack enters the machine.

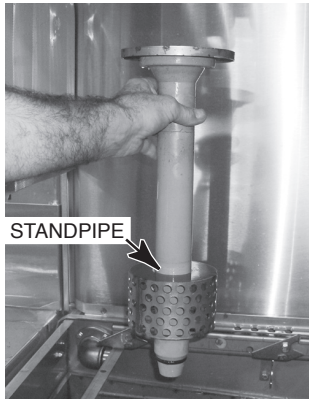

Fig. 13

Install the rear and side strainer pans and lower the strainer bucket (Fig. 15).

Install the upper wash arm (Fig. 14) and the lower wash arm (Fig. 15) in the scrapper with all end caps. Push arm onto the connector pipe so the opposite end is held by the guide; then lift or lower into position.

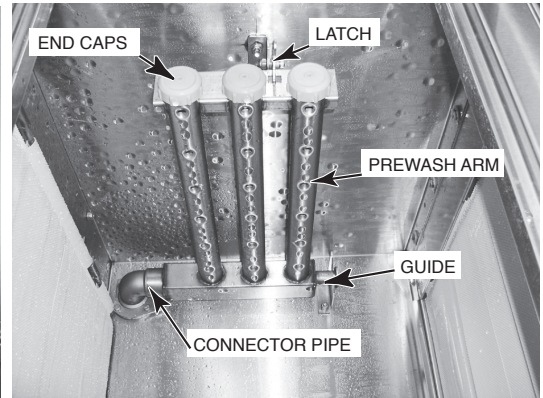

Fig. 14

Wash / Rinse Tanks

Install the standpipe(s) in the tank(s) (Figs. 13 and / or 16). Standpipe without strainer (Fig. 16) goes in second / third tank.

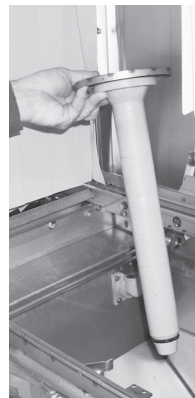

Fig. 16

Install the strainer pan and the strainer bucket (Fig. 18).

Install the upper wash arm (Fig. 17) and the lower wash arm (Fig. 18) with all end caps. Push arm onto the connector pipe so the opposite end is held by the guide (Figs. 17, 18); then lift or lower into position.

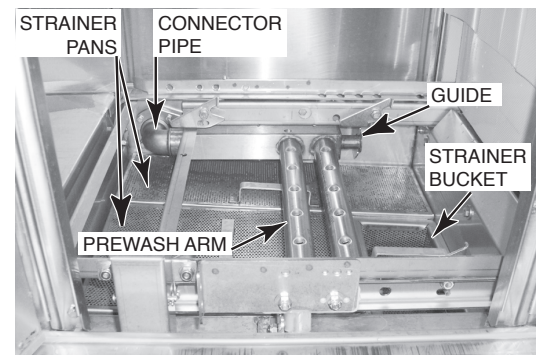

Fig. 15

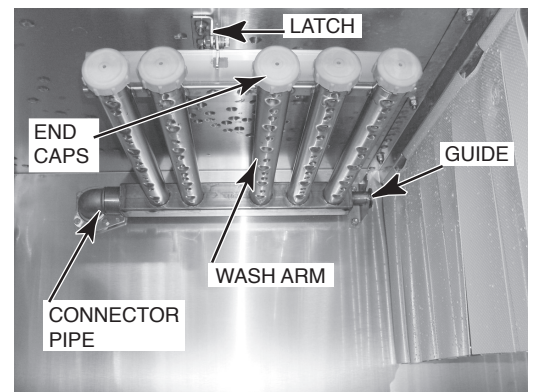

Fig. 17

Curtains & Doors

Hang all curtains according to the appropriate curtain diagram (pages 15 – 16).

Close all doors: This lowers and seats the standpipe(s).

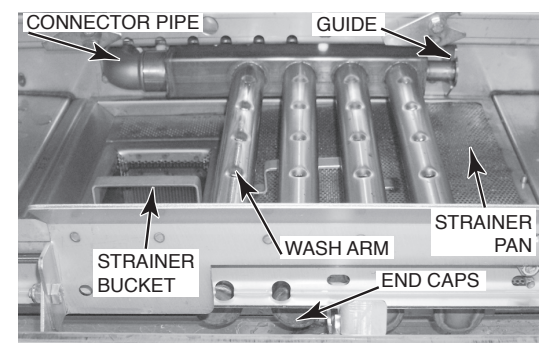

Fig. 18

CURTAIN INSTALLATION

Curtains are keyed for proper installation.

CL44e, CL54e

CL64e

RIGHT TO LEFT
←

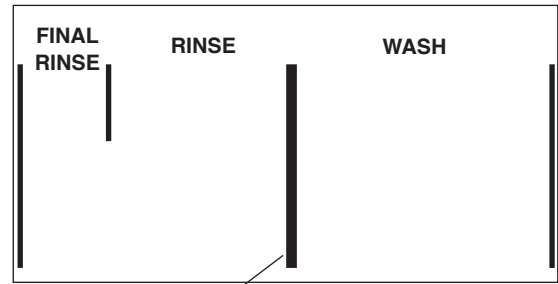
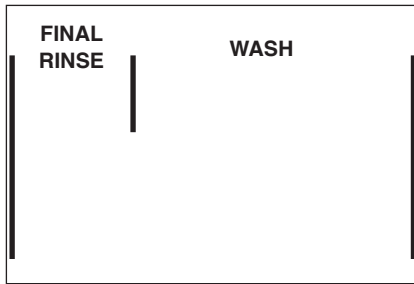

LEFT TO RIGHT
⇒

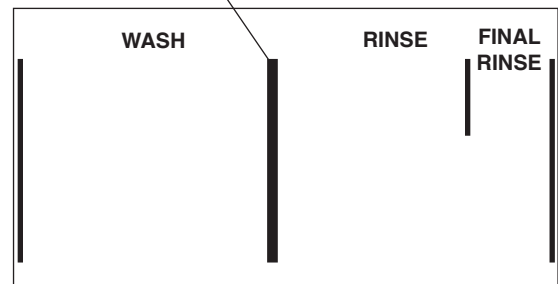
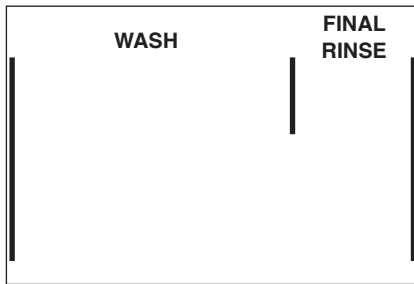

MIDDLE CURTAIN IS SPECIAL, LONG

Single-Tank Machines with Power Scraper (CLPS) or Corner Scraper (CLCS)

CLPS66e, CLPS76e

CLCS66e, CLCS76e

RIGHT TO LEFT
←

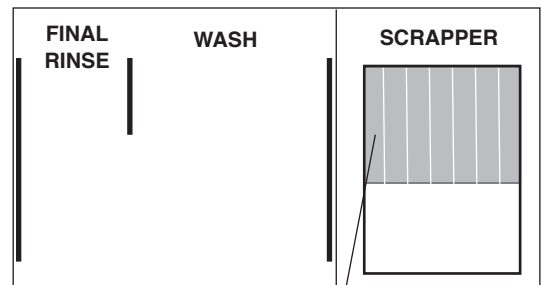
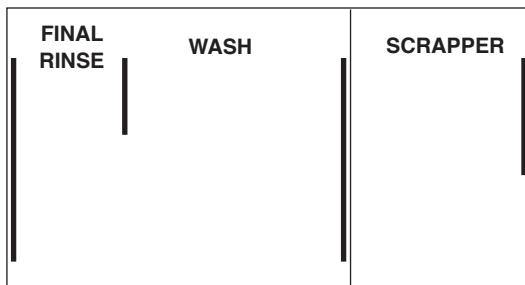

LEFT TO RIGHT
⇒

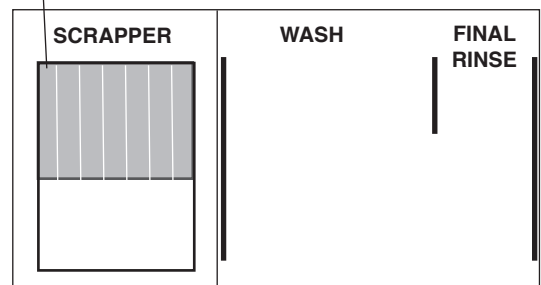
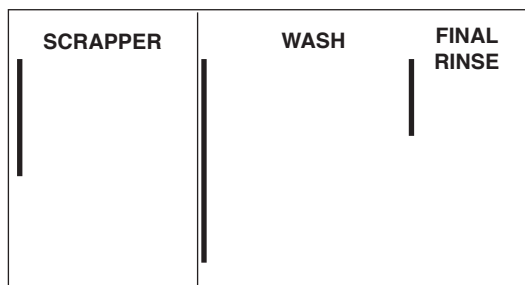

ON CORNER SCRAPER MODELS, THE FIRST CURTAIN IS SHORT AND IS POSITIONED ABOVE THE ENTRY

Two-Tank Machines with Power Scrapper (CLPS)

CLPS86e

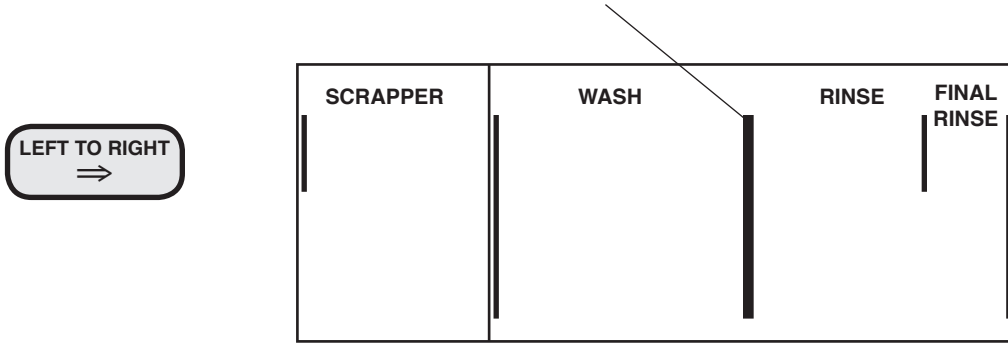
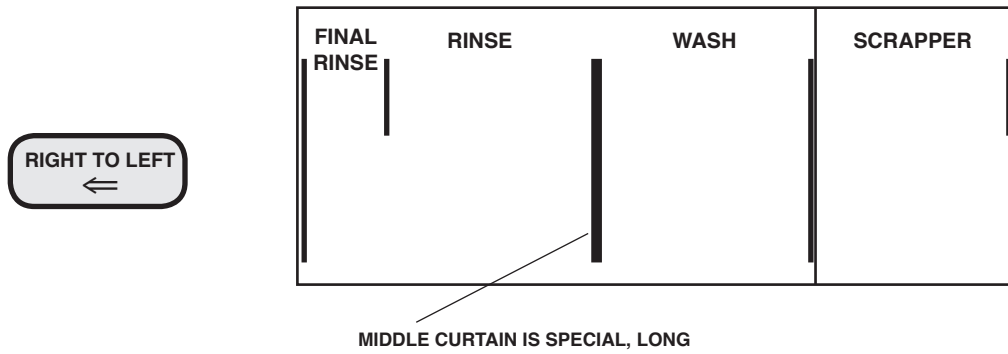

Two-Tank Machines with Corner Scrapper (CLCS)

CLCS86e

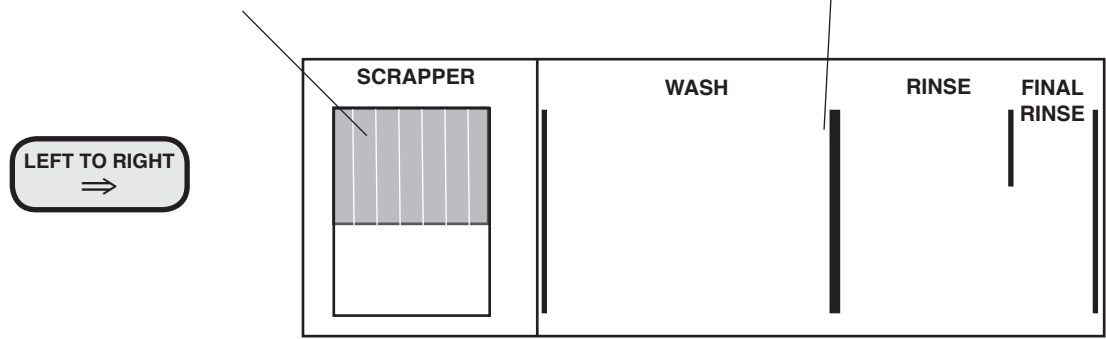
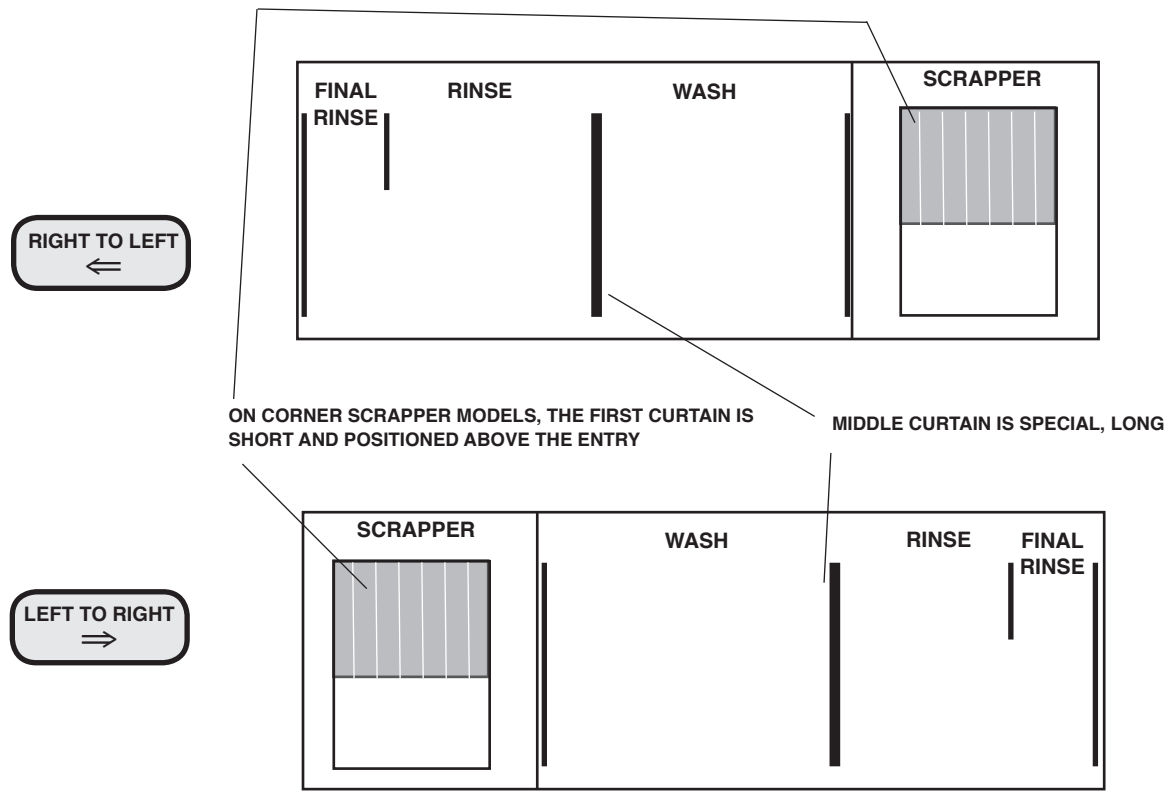

KEYPAD AND DISPLAY

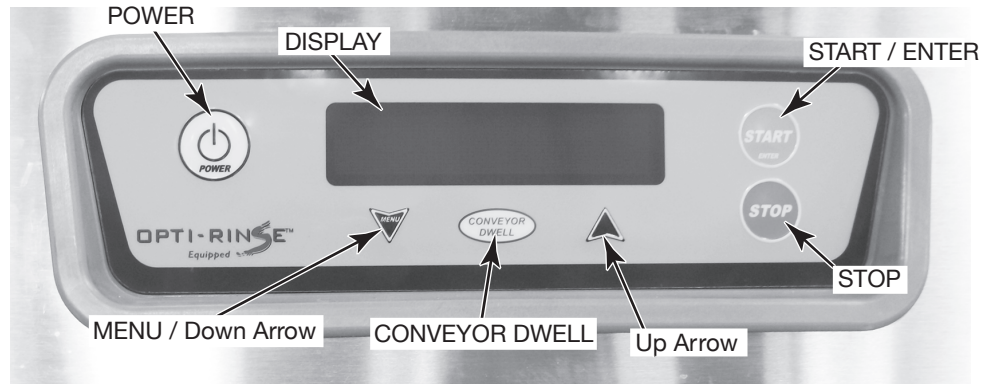

Fig. 19

The controls are mounted on top of the dishwasher. The Keypad and Display are mounted in front of the control box (Fig. 19).

FILLING THE DISHWASHER

All water supply valves must be opened and the electric supply must be turned on before the machine will function. Make sure Preparation and Curtain Installation are done, pages 14 – 16.

Close all doors. To begin filling after the machine is ready, press the POWER key (Fig. 19).

If the machine is equipped with a Power Scrapper or Corner Scrapper, the scrapper tank will fill with overflow water from the wash tank.

STARTING THE GAS HEAT DISHWASHER (When Equipped with Gas Heat)

1. **⚠ WARNING** Read the Safety Information on page 2 before operating this dishwasher.
2. Turn main gas supply to the dishwasher ON.
3. Wait for 5 minutes to clear out any gas. If you then smell gas, **STOP!** Follow all safety information covered on page 2 in IMPORTANT FOR YOUR SAFETY.
4. If you don't smell gas, turn the manual gas valve On.
5. Press the POWER key on the keypad (Fig. 19). Dishwasher will fill automatically (refer to Filling the Dishwasher, this page). After the tank has filled, the burner will ignite if heat is required. The ignition system includes a 15-second pre-purge period before ignition occurs.
6. If the dishwasher will not operate, press the POWER key on the keypad (Fig. 19) and turn the manual gas valve Off. Call your local Hobart service office or gas supplier.

MINIMUM TEMPERATURES

The water temperatures in the tanks and rinse arms are regulated by the microprocessor control. The control is preset at the factory and no adjustment should be required. If an adjustment is necessary or if the machine is to operate at low temperature using chemical sanitizer, contact your local Hobart service office or refer to instructions for conversion. The digital display verifies proper water temperature during operation.

Minimum Temperatures Using High-Temperature Sanitizing

Single-Tank Models	Wash Tank	Rinse Tank	Final Rinse
CL44e, CLPS66e, CLCS66e CL54e, CLPS76e, CLCS76e	160°F	—	180°F
Two-Tank Models			
CL64e, CLPS86e, CLCS86e	150°F	160°F	180°F

Minimum Temperatures Using Low-Temperature, Chemical Sanitizing

Single-Tank Models	Wash Tank	Rinse Tank	Final Rinse
CL44e, CLPS66e, CLCS66e CL54e, CLPS76e, CLCS76e	130°F	—	120°F
Two-Tank Models			
CL64e, CLPS86e, CLCS86e	130°F	130°F	120°F

If the tank is accidentally drained before turning off the power switch, the float-controlled, low-water protector switch will automatically stop the tank heat. When the proper water level is returned, the tank heat will automatically restart. DO NOT use the low-water protection as a power on-off switch. Press the POWER key on the keypad to turn the machine off when not in use.

Alternative Temperature Display Names

This table shows the possible temperature names that may appear on the display. The Long Name is equivalent to the Short Name. Temperature Display Names vary for different models.

ALTERNATIVE TEMPERATURE DISPLAY NAMES

Indicated Temperature	Long Name	Short Name
Power Scrapper Tank	Scrapper	PS
Wash Tank	Wash	Wsh
Power Rinse Tank	Rinse	Rns
Final Rinse	FinalRinse	FnlRns

Low FR Temp. Alert

Displays a message to indicate that the final rinse temperature was below the minimum requirement for a short time. This feature can be enabled from the Parameters Menu, refer to page 27.

Tank Temperature Alert

Displays a message if any tank goes below the minimum for a certain amount of time. This feature can be enabled from the Parameters Menu; refer to page 27.

DISHWASHING

After the machine has filled, start the pumps by pushing the START / ENTER key on the keypad (Fig. 19) or by inserting a rack into the machine.

The machine will operate only if the tanks have filled to the proper level and all doors are closed. Press the STOP key on the keypad to stop the conveyor motor and pumps.

Pre-scrap dishes thoroughly to remove large food particles and debris. Never use steel wool on ware that is to be loaded into the dishwasher.

Stack dishes in the racks. Do not stack dishes one on top of another, as water must have free access to both sides of every dish. Stand plates and dishes up edgewise (Fig. 20). Cups, glasses and bowls should be inverted in an open-type rack (Fig.20) or a compartmented rack. Silverware and other small pieces may be scattered loosely over the bottom of an open-type, flat-bottom rack. To minimize splash, position trays in the rack in the same direction as the motion of the conveyor (Fig. 20).

DO NOT attempt to wash large items (pots, pans, trays, etc.) without first checking to make sure they will fit through the machine opening. Such large items must not be washed in this dishwasher unless they will easily pass through it.

DO NOT allow foreign objects to enter the dishwasher, especially metallic contaminants.

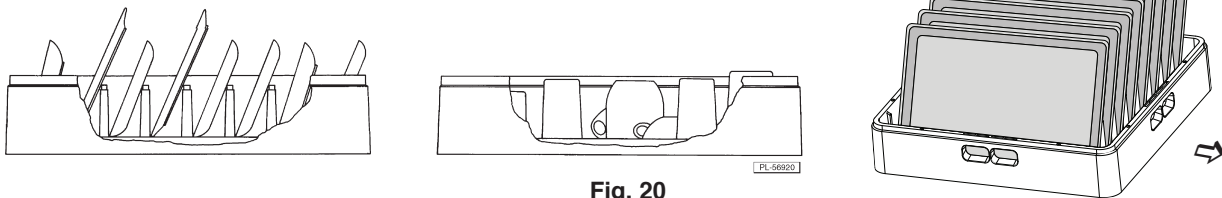

When one rack has been loaded, slide it part way into the machine until the conveyor dogs catch the rack. Start loading another rack when the previous rack has completely passed the curtains. The operation of the dishwasher is automatic. When a rack enters the machine, the pumps and conveyor automatically start. Each rack moves through the power scrapper (if present), the wash and the rinse zones, then out onto the clean dish table. The rinse lever is actuated by the dish rack when it is present in the rinse zone and automatically shuts off the final rinse water when no rack is present.

Allow dishes to drain and air-dry before removing the ware from the rack.

The conveyor dwell feature, standard, allows the operator to stop the conveyor in order to wash heavily soiled dishes for a longer time. When the dish rack reaches the wash chamber, push the CONVEYOR DWELL key on the keypad (Fig. 19) to momentarily stop the conveyor. To restart the conveyor, press either the START / ENTER or the CONVEYOR DWELL keys on the keypad (Fig. 21).

If the rack jams or if the load becomes excessive, an overload mechanism shuts off the conveyor drive motor and 'Clear Conveyor Jam' displays. Open the doors and remove the jam. After the jam is cleared, close the doors and push the START / ENTER key on the keypad (Fig. 19) to restart the dishwasher.

All tank temperatures are shown on the Display (Fig. 19) when the machine is in operation. The Final Rinse temperature displays --- until a rack is in the rinse zone; then, the Final Rinse water temperature displays. After the ware exits the rinse zone, the Final Rinse temperature display returns to --- .

Optional Table Limit Switch

If a rack reaches the end of the unload table and trips the table limit switch, the conveyor, pumps and final rinse shut off. The display alternates between the tank names and 'Unload Dishes'. After the rack is removed and the table limit switch resets, normal operation of the dishwasher resumes.

Auto-Timer

To conserve energy, if no rack enters the machine for a preset amount of time, the Auto-Timer counts down and the pumps and conveyor shut off. Tanks continue to heat, and tank temperatures display. To resume operation, insert a rack or press the START / ENTER key on the keypad (Fig. 19).

NOTE: The Auto-Timer shut off setting is preset from the factory at 45 seconds. You can adjust the setting from 30 to 180 seconds (15 second increments). Refer to the Parameters Menu, page 27.

Energy Saver Mode

After a period of machine inactivity, the control initiates Energy Saver Mode (ESM): All warewasher components are turned off, and the display on the control dims, displaying 'Energy Saver Active / Press STOP to Exit'. To exit Energy Saver Mode, press the STOP key (Fig. 19). You may press the POWER key to completely turn the machine off. The period of machine inactivity prior to ESM can be set from 1 to 6 hours in the Parameters Menu; 2 hours is the factory setting. Refer to page 27.

Dirty Water Mode

Three settings are provided; refer to Parameters Menu on page 27.

Disabled – No alarm displays. This is the factory setting.

Alert Only – After a period of operation, 'Water Change Req'd' displays but the control allows machine operation until the water is changed.

Alert & Lockout – After a period of operation, 'Change Water Soon' displays for 5 minutes, alerting you to change the water; then, 'Water Change Req'd' displays and further machine operation is prevented until tanks are drained and refilled.

CLEANING

The machine must be thoroughly cleaned at the end of each working shift, or at least twice a day. Use only products formulated to be safe on stainless steel. Use a damp cloth and mild soapy water.

1. Press the POWER key on the keypad to turn the machine Off (Fig. 19).

⚠ WARNING Disconnect the electrical power to the machine and follow lockout / tagout procedures before you begin cleaning. There may be multiple circuits. Be sure all circuits are disconnected.

2. Open the doors. Standard door interlock switches prevent machine operation with inspection doors open.
3. Visually inspect the upper and lower final rinse nozzles to make sure they are free of debris.
4. Open drain(s) by pulling drain lever(s) up (Fig. 21).

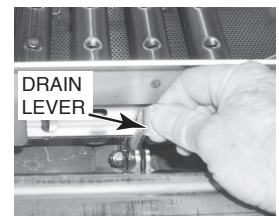

Fig. 21

5. Remove wash arms. Remove wash arm end caps (Fig. 22) and push any nozzle obstructions into the wash arms. Thoroughly flush the wash arms in a sink. Replace the wash arm end caps.

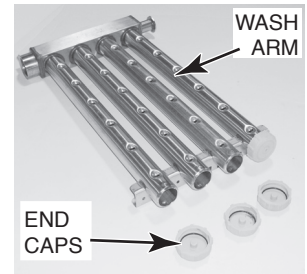

Fig. 22

6. Before removing strainer basket(s) and pan(s), clean off any debris from machine walls using a hose with spray nozzle. Flush all debris toward the strainers.

7. Clean dish tables by flushing any debris into the dishwasher.

8. Remove all strainer pan(s) and strainer basket(s). Empty contents into garbage can or disposer and thoroughly clean pan(s) and basket(s) in a sink. DO NOT strike strainer pan(s) or strainer basket(s) on solid objects to dislodge debris. Refer to Figs. 15 & 18 on page 14.

9. When tanks are empty, remove the standpipe and clean the pump intake strainer(s) on the bottom of the standpipe or at the bottom of the tank (Figs. 13 & 23).

10. Remove curtains. Thoroughly scrub, rinse and allow curtains to dry at the end of each day's operation.

11. Thoroughly wash out the interior of the machine with a hose fitted with a spray nozzle. Remove remaining soil with a cloth or soft brush and mild cleanser. Flush out again with hose spray. Do not allow food soil to accumulate on the bottom of the tank.

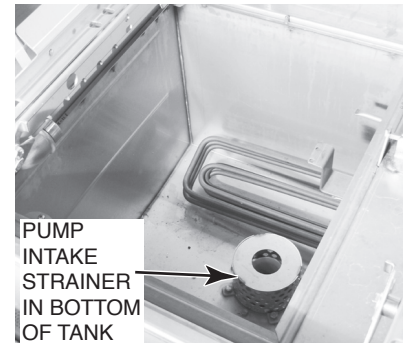

Fig. 23

12. Return all standpipe(s), strainer pan(s) and strainer basket(s) to their proper locations (Figs. 13, 16, 15 & 18) on page 14.

13. Insert the upper wash arm(s) straight onto the connector pipe. Rest the extension on the guide. Rotate the arm upward to latch it.

14. Insert the lower wash arm(s) straight onto the connector pipe. Rest the extension on the guide. Swing the front of the arm down until level to fully position it.

15. Leave doors open and curtains removed while machine is not in use to allow the interior to air out and dry. Install curtains after machine has dried out.

- **NOTICE** DO NOT attempt to clean Opti-Rinse final rinse nozzle(s). Opti-Rinse nozzle(s) should be replaced if they become clogged or if the spray pattern is ineffective.
- Never use steel wool to clean warewasher surfaces. Use only products formulated to be safe on stainless steel.
- Reassemble standpipe(s), strainer pan(s) and strainer basket(s), per page 14.
- Rehang curtains after interior has dried out. Refer to pages 15 – 16.

DELIMING RECOMMENDATIONS

For questions about frequency of delimiting, follow your chemical representative's recommendations based on visible lime build-up or reduced warewashing performance. The factory default value for the 'Delime Interval' is 0 hours; this disables the delime recommendation message. The 'Delime Interval' can be enabled by increasing the 'Delime Interval' to a higher value. Refer to Delime Interval on the Parameters Menu on page 27. If enabled, the 'Delime Recommended' message will display after the fill and final rinse have operated for the delime interval.

Delimiting instructions: Follow instructions on the delime-chemical container. During delimiting, machine should be on with pumps running, but the conveyor can be idle. Press the CONVEYOR DWELL key on the keypad (Fig. 19) to turn off the conveyor motor and conveyor during delimiting.

The 'Delime Recommended' display message will not clear itself automatically after the machine has been delimited. To clear the message, follow these instructions:

- Delime the machine: Follow all applicable instructions.
- Enter the Manager Mode (steps 2 – 10, below) use Mgr. Code 1001 per page 26 unless reset to a different number on page 27.
- Find the 'Clear Delime Message' screen by proceeding to step 12, below.
- Press the START / ENTER key on the keypad to clear the delime message (step 12). The Main screen returns, showing the tank temperatures (return to step 1). Clearing the message also resets the delime timer back to zero.

CLEARING THE 'DELIME RECOMMENDED' MESSAGE

	Display Message	Key to Press	Function
1.	[Tank Names] [Tank Temperatures]	MENU / Down Arrow	
2.	Exit to Main ? Yes	MENU / Down Arrow	
3.	Enter Security Code? O Yes	START / ENTER	Answer Yes
4.	Security Code: 0***	Up Arrow	Change 0 to 1
5.	Security Code: 1***	START / ENTER	Go to next digit
6.	Security Code: *0**	START / ENTER	Go to next digit
7.	Security Code: **0*	START / ENTER	Go to next digit
8.	Security Code: ***0	Up Arrow	Change 0 to 1
9.	Security Code: ***1	START / ENTER	Accept 1001
10.	Enter Security Code? M Yes	MENU / Down Arrow	Letter in lower left should be 'M'.
11.	Edit Parameters?	MENU / Down Arrow	
12.	Clear Delime Message? Yes	START / ENTER	Answer Yes Return to Step 0.

DOs and DON'Ts for Your New Hobart Warewasher

DO assure proper water hardness of 3 grains per gallon or less.

DO pre-scrap dishes thoroughly.

DO use only detergents recommended by your chemical professional.

DO, at the end of the day, thoroughly clean the machine, rinse and dry (leave doors open).

DO closely follow your chemical professional's prescribed deliming schedule.

DO use only products formulated to be safe on stainless steel.

DO NOT use detergents formulated for residential dishwashers.

DO NOT allow food soil to accumulate on the tank bottom.

DO NOT exceed chemical manufacturer's recommended concentrations for detergent, sanitizer, rinse aid or lime scale remover.

DO NOT use steel wool to clean ware or warewasher surfaces.

DO NOT allow foreign objects to enter the unit, especially metallic contaminants.

NOTE: Failure to follow use, care and maintenance instructions may void your Hobart warewasher warranty.

PROGRAMMING

PROGRAMMING SECURITY LEVELS

Your warewasher's microprocessor allows customization options for machine operation for cleaning your ware, maintaining required tank temperatures and other functions related to your kitchen operation. To activate or change these features, the programming edit mode must be entered at an appropriate level.

It is recommended that the warewasher stay in the lowest security level to prevent options from being modified from what is expected and / or acceptable. The security level will automatically revert back to Operator when any of the following occur:

- 1) No keys on the keypad are pressed for 10 minutes or more.
- 2) The machine is placed in Standby by pressing the POWER key.
- 3) An invalid Security Code is entered on the 'Enter Security Code?' screen.

The names and descriptions of the security levels are listed from lowest to highest levels.

NOTE: The letter to the right of the name is the same as the letter you will see at the lower-left corner of the 'Enter Security Code?' screen: O or M. Refer to Entering the Parameters Menu, page 26, for more details.

NOTE: The security level does not, by itself, affect the operation of the machine or inhibit the use of the START, STOP or POWER keys. All of these basic functions are always available in any security level.

Operator – O

The Operator level is the most basic security level. It is the one that is initiated by default when the unit is powered up. No security code is required to enter the Operator security level. From this level you may enter a Security Code to elevate to a higher security level.

Manager – M

The Manager level is the highest level attainable by the user. It requires the Manager Code to be entered to access the Manager level.

The Manager security level allows access to all of the options listed in either the Parameters Menu — Table 1 and / or the Communications Setup Menu — Table 2. It is recommended that power to the machine be cycled off and on after any Manager level options are modified and saved.

The Security Code for the Manager level can be changed by a kitchen manager or anyone with the Manager Code. The default code is 1001. As such, it is recommended that this code be changed from the default and that the new code be stored in a safe place. If the Manager code is ever lost or forgotten, it can be reset by Hobart Service.

NOTE: Having Hobart Service reset the Manager Code is not covered under either the basic or the extended warranties.

PROGRAMMING INSTRUCTIONS

All customization is performed through the on-screen menu using the Up arrow, MENU / Down arrow and START / ENTER keys located on the keypad on the top of the machine (Fig. 24).

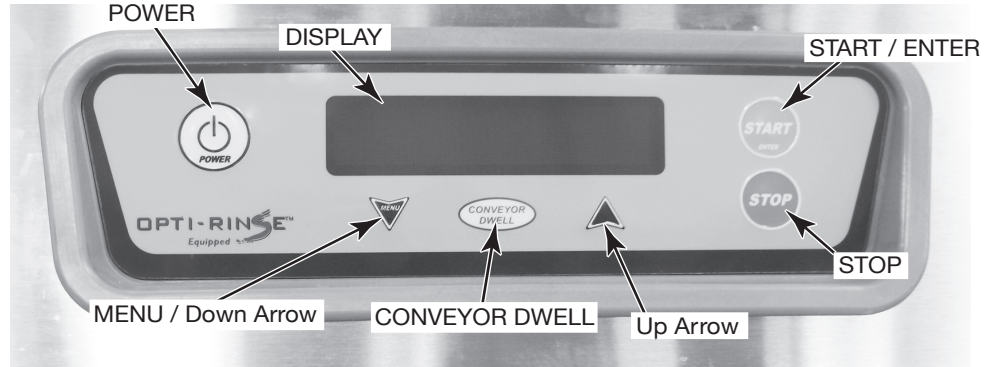

Fig. 24

Menu Display Prompts

The following prompts are used inside the menus:

- The Up and MENU / Down arrow keys are used to change parameter values and to navigate the menu.
- The START / ENTER key is used to accept a value, to perform a specified action or to enter a submenu. Pressing this key while in the menu will **not** start the conveyor and pumps (if not already on). To start the machine while editing a menu, allow a rack to enter the machine or exit the menu before pressing the START / ENTER key.
- The STOP key will always cancel what you are doing, discard any changes you have made since the last save, return to the main screen and stop the machine.
- The text just to the left or right of the circle icon (●) on the display screen shows what action or command will occur if the START / ENTER key is pressed.
- The up/down arrow icon in the display shows the line or value that will change if the UP or DOWN arrow key is pressed.
 - A pair of solid arrows on the second line (◀▶), indicates that the displayed value is the value stored in the control.
 - A pair of hollow arrows on the second line (◊), indicates the value has been changed but has not yet been stored.

Entering the Parameters Menu

The Parameters menu can be entered, and individual options can be modified anytime the machine is operating or idling.

To enter the Parameters Menu you must first enter the Security Code:

STEP 1. Press the MENU / Down key from the main screen.

STEP 2. You are prompted on-screen, asking if you wish to exit the menu. Do not press START / Enter or you will exit back to the main screen showing tank names and temperatures. Instead, press the MENU / Down Arrow key to continue.

	Display Message	Key to Press	Function
1.	[Tank Names] [Tank Temperatures]	MENU / Down Arrow	
2.	Exit to Main ? Yes	MENU / Down Arrow	
3.	Enter Security Code? O Yes	START / ENTER	Answer Yes
4.	Security Code: 0***	Up Arrow	Change 0 to 1
5.	Security Code: 1***	START / ENTER	Go to next digit
6.	Security Code: *0**	START / ENTER	Go to next digit
7.	Security Code: **0*	START / ENTER	Go to next digit
8.	Security Code: ***0	Up Arrow	Change 0 to 1
9.	Security Code: ***1	START / ENTER	Accept 1001
10.	Enter Security Code? M Yes	MENU / Down Arrow	Letter in lower left should be 'M'.
11.	Edit Parameters? Yes	START / ENTER	
12.	Sanitizing Mode High Temp		This is the first parameter

STEP 3. You reach the 'Enter Security Code?' screen. Press the START / Enter key to indicate that you want to enter the code.

STEPS 4 – 10. The prompt 'Security Code:' displays on the top line and a single digit and three asterisks [0***] displays on the bottom line. Use the Up arrow and MENU / Down arrow keys to change the Security Code to the appropriate value. The default Security Code to enter Manager level is 1001.

The security code can be changed by anyone with access to the Parameters Menu, and it is recommended to change it from the default. If the code is ever lost for some reason, it can be reset by Hobart Service, but this is not covered under either basic or extended warranties.

After pressing START / Enter on the fourth digit (STEP 9), the prompt 'Enter Security Code?' returns to the first line of the display screen (STEP 10). You have correctly entered the manager security level if 'M' is displayed in the lower left corner. If M does not display, repeat steps 3 – 10.

STEP 11. Press START / Enter to enter the Parameters Menu.

Navigating the Parameters Menu

If Sanitizing Mode displays (STEP 12), you are in the Parameters Menu. The display shows the first editable parameter. You can use the Up or MENU / Down keys to explore the parameters menu.

Pressing the START / ENTER key allows you to enter that parameter and modify the setting.

For a list of parameter options, refer to the Parameters Menu – Table 1 on page 27. For a list of communications options, refer to the Communications Menu – Table 2 on page 28.

PARAMETERS MENU — TABLE 1

Parameter Name	Description	Possible Values	Default Value
Sanitizing Mode	Sets the operating temperatures that regulate the tank heaters and the internal booster (if provided): high temperature sanitizing mode, or low temperature, chemical sanitizing mode.	High Temp. or Low Temp.	High Temp.
Auto-Timer	Pumps and conveyor shut down after this period of inactivity to save energy. Refer to page 20.	30 to 180 (in 15 second increments)	45
Low FR Temp. Alert	Enables or disables a visual alert on the display that indicates that Final Rinse water temperature is below the required minimum of 180°F (82°C). When enabled, a message will display notifying the user of this condition. However, machine operation will not change and ware will continue to run through the machine as expected. After the temperature increases past the minimum, the message stops. When disabled, there will be no extra message indicating a low-temperature event; however, the temperature display will still show the current Final Rinse water temperature. Refer to page 18.	Disabled or Enabled	Disabled
Tank Temp. Alert	Displays a message that the water temperature of a certain tank is below the minimum required. After the temperature increases past the minimum, the message stops. Refer to page 18.	Disabled or Enabled	Disabled
Delime Interval	Sets the delime interval from 0 to 1000 hours. A setting of 0 disables this feature. Up arrow increases 10 hours, Down arrow decreases. Hold Up or Down arrow for faster movement.	0 to 1000	0
Dirty Water Mode	<u>Disabled</u> : Ignores dirty water. <u>Alert Only</u> : Displays 'Water Change Req'd' after a period of operation but does not require refilling. <u>Alert & Lockout</u> : Displays 'Change Water Soon' for 5 minutes after a period of operation; then 'Water Change Req'd' displays and machine cannot run until tank(s) are drained and refilled. Refer to page 20.	Disabled, Alert Only or Alert & Lockout	Disabled
Dirty Water Interval	Sets the period (in hours) of rinsing before an alert is shown. This option is only available when Dirty Water Mode is set to 'Alert Only' or to 'Alert & Lockout'.	1 – 6	4
Energy Saver Mode (ESM)	ESM begins after a period of machine inactivity. Up arrow increases by 1 hour. Down arrow decreases by 1 hour. Refer to page 20.	1, 2, 3, 4, 5, 6	2
Change Mgr. Code	Sets a new Security Code for access to the Manager Level parameters. It is recommended to change this code from the default value and store the new code where all kitchen managers, but no operators, can access it.	0000 to 8888	1001
Edit Communications Setup?	Press START / ENTER to access the Communications Setup Menu, to edit settings for the NAFEM Data Protocol. Refer to Communications Setup Menu – Table 2, page 28. Press Down arrow or Up arrow to move down or up the menu.		
Save Settings and Exit?	Press START / ENTER to save the changed settings, exit the Parameters Menu and return to the main screen. Any settings that were changed are saved and most become active immediately. If one or more settings are not activated immediately, a message will display indicating that you need to cycle power off and on to make them active.		
Cancel Settings and Exit?	Press START / ENTER to exit the Parameters Menu and return to the main screen. Any settings that were changed are cancelled and revert back to the previously saved values.		

Communications Setup Menu

The Communications Setup Menu — Table 2 lists the communication option, a short description, a list of possible values it can have and the factory default value.

COMMUNICATIONS SETUP MENU — TABLE 2

Parameter Name	Description	Possible Values	Default Value
NAFEM DP Baud	Adjusts the baud rate of communication between the dishwasher and a NAFEM Data Protocol (NDP) Gateway (sold separately). This must match the setting in the NDP Gateway. Refer to documentation that came with the NDP Gateway for instructions on where to find this value.	9600, 19,200 or 38,400	9600
NAFEM DP ID	Adjusts the machine-specific ID for use on a NAFEM Data Protocol network. Each device on the network must have a unique ID. Please refer to any documentation that came with other NDP-compliant devices to verify that all IDs on the network are unique.	1 to 247	5
Exit to Params?	Press START / ENTER to exit the Communications Setup menu and return to the Parameters menu. Any settings that were changed are only saved by choosing the 'Save Settings and Exit?' option on the Parameters Menu. Changing communication values typically requires machine power to be cycled off and on.		

MAINTENANCE

⚠ WARNING Disconnect the electrical power to the machine and follow lockout / tagout procedures. There may be multiple circuits. Be sure all circuits are disconnected.

VENT

When cool, check the vent of this dishwasher every six months for obstructions.

LUBRICATION

None required.

SERVICE

Contact your local Hobart Service office for any repairs or adjustments needed on this equipment. If a gas orifice fitting is to be replaced, have it serviced by qualified Hobart Service personnel. Long-term service contracts are available on this and other Hobart products.

TROUBLESHOOTING

SYMPTOM	POSSIBLE CAUSE
No Machine Operation.	<ol style="list-style-type: none"> 1. Blown fuse or tripped circuit breaker at power supply. 2. Inspection door(s) not closed. 3. Conveyor has jammed. 4. The Auto-Timer may have timed out. Push START or insert rack. 5. If table limit switch is used, the switch may be tripped. 6. The machine is in Energy Saver Mode. Press STOP on the keypad to resume.
Dishes Not Clean.	<ol style="list-style-type: none"> 1. Insufficient wash water. Drain obstruction causing an open drain condition. Worn or torn drain O-ring allowing wash water to drain. 2. Missing end cap from wash arm. 3. Wash arm nozzle obstruction. 4. Worn or torn manifold O-ring allowing wash water to drain. 5. Loss of water pressure due to pump obstructions. 6. ⚠ WARNING Disconnect the electrical power to the machine and follow lockout / tagout procedures. There may be multiple circuits. Be sure all circuits are disconnected. Drain tank(s) and check for any obstruction at the pump intake. 7. Incorrect water temperature. Check circuit breaker to electric heat supply, or main steam valve, or gas supply valve. Make certain that valve is completely open. 8. Incorrect detergent dispensing. Contact your detergent sales representative. 9. Strainer pans or buckets need to be emptied and / or cleaned. 10. Tanks may need to be drained and filled with clean water.
Leaking Valve.	<ol style="list-style-type: none"> 1. Foreign material preventing proper valve operation. A critical period is soon after installation when pipe compound or metal shavings may lodge at the valve seat. If problem is with a solenoid valve, it is recommended that you contact your local Hobart Service office.
Spotting of Silverware, Glasses and Dishes.	<ol style="list-style-type: none"> 1. Improperly loaded racks. 2. Incorrect final rinse water temperature (180°F or 120°F, minimum, page 18). 3. Loss of water pressure due to pump obstruction. ⚠ WARNING Disconnect the electrical power to the machine and follow lockout / tagout procedures. There may be multiple circuits. Be sure all circuits are disconnected. Drain tank(s) and check for any obstruction at the pump intake. 4. Clogged wash arm nozzles. 5. Improper water hardness (3 grains per gallon or less is recommended). 6. Incorrect detergent for water type. Contact chemical supplier. 7. Clogged rinse nozzle(s). 8. Problem with Rinse Aid dispenser. Contact chemical supplier.
Low Final Rinse Temperature With Built-In Booster Heater.	<ol style="list-style-type: none"> 1. Tank float not 'up' permitting heat to turn on or float is malfunctioning. 2. Overtemp protector tripped. Contact Hobart Service. 3. Circuit breaker to heat system tripped. 4. Incoming water is below minimum temperature. 5. If your temperature control needs adjustment, or if there is a booster heater failure, contact your local Hobart Service office.

NOTE: If symptom(s) persists after possible causes have been checked, contact your local Hobart Service office.

SYMPTOM	POSSIBLE CAUSE
Inadequate Rinse.	<ol style="list-style-type: none"> 1. Dirty line strainer (Fig. 25) causing reduced water flow. Turn off water supply, remove strainer cap and screen. Clean screen. Reassemble. 2. Low supply line pressure or dirty in-line rinse arm strainer. 3. Clogged rinse nozzle(s).
Continuous Rinse	<ol style="list-style-type: none"> 1. Rinse actuator (Fig. 26) not moving freely. ⚠ WARNING Disconnect the electrical power to the machine and follow lockout / tagout procedures. There may be multiple circuits. Be sure all circuits are disconnected. Check actuator for free movement. 2. Check for foreign object in mechanism, i.e., silverware. 3. Rinse valve failed or jammed open. 4. Standpipe(s) not seated properly — water draining and fill remains on.
No Wash Tank Heat, Tanks Not Heating.	<ol style="list-style-type: none"> 1. The machine is equipped with low water safety devices which shut off heat if water level drops. Check for proper water level. 2. Circuit breaker(s) to heat system tripped (electric heat). 3. Check heat float for debris and free movement. 4. Overtemp protector tripped or failed heating element (electric heat). Contact Hobart Service. 5. The main gas supply valve is not open (gas heat). 6. Make sure all standpipes are properly seated. 7. Steam supply valve(s) are not opened completely or supply pressure is too low (steam heat). 8. Bucket trap not functioning correctly (steam heat). 9. Improperly operating steam solenoid valve(s) (steam heat).
No or Slow Fill.	<ol style="list-style-type: none"> 1. Door(s) are open. 2. Main fill (water supply valve) could be closed. 3. Upper and / or lower fill floats do not move freely. 4. Dirty line strainer (Fig. 25) causing reduced water flow. Turn off water supply, remove strainer cap and withdraw and clean screens. Reassemble. 5. Problem with solenoid valve. 6. Low incoming water supply pressure. 7. Drain(s) open. 8. Standpipe(s) not seated properly or placed in wrong tank.
Leaking Vacuum Breaker.	<ol style="list-style-type: none"> 1. Foreign material or corrosion could be preventing proper valve operation. Shut off all incoming water supply line(s). Unscrew and lift bonnet from valve body. Clean valve and reassemble.

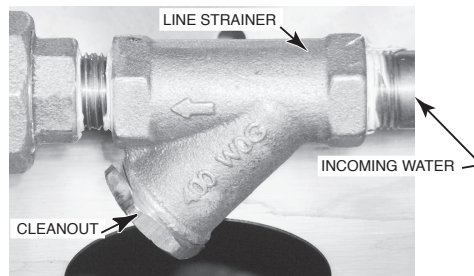

Fig. 25

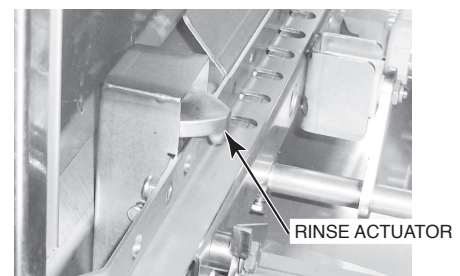

Fig. 26

NOTE: If symptom(s) persists after possible causes have been checked, contact your local Hobart Service office.

DISPLAY READS	POSSIBLE RESOLUTION
Door(s) Open	Close all inspection doors.
Unload Dishes	Remove rack from table limit switch at end of clean dish table (unload end).
Clear Conveyor Jam	Clear jam. Remove rack from machine. Press START and rerun rack.
Probe Err - [Tank Name]	Ensure lower float assembly in indicated tank is not visibly damaged and sufficient water is in the tank to cover the lower float.
FnI Rinse Temp Low	<ol style="list-style-type: none"> 1. Check that the final rinse booster tank circuit breaker is on and not tripped (if equipped). 2. Check that the final rinse booster tank overtemp circuit is not tripped (if equipped). 3. Ensure that the building supply water to the dishwasher or final rinse booster tank is at the minimum specified temperature.
Probe Error — FnIRns	Ensure that the supply water valve to the final rinse booster is open.
Check Water Level	<ol style="list-style-type: none"> 1. Ensure that all drains are closed and free of debris. 2. Check that the water supply valve is open. 3. Open inspection doors and check the water level of all tanks. Water should be about one inch down from the top of the strainer pan or higher. 4. If tanks fail to fill after another 20 minutes, contact Hobart service.
Reset Required	Place machine in Standby by pressing the Power key. Wait at least 60 seconds before powering on the machine.
Delime Recommended	Inspect machine interior for lime deposits. Refer to Deliming Recommendations, page 22.
Change Water Soon	At your earliest convenience, change the wash water for best washability.
Water Change Req'd	Drain all tanks and allow machine to refill.
Energy Save Active Press STOP to Exit	Due to inactivity, the machine has gone into an idle mode; the heat has turned off. Press the STOP key to resume normal operation. Monitor temperatures as you resume warewashing activity.

NOTE: If symptom(s) persists after possible causes have been checked, contact your local Hobart Service office.

