

## Heated Display Cases

Full Service or Self Service



TY2SYS-72



TY2-72

### Models:

**TY2-48; TY2SYS-48 SERIES**

**TY2-72; TY2SYS-72 SERIES**

**TY2-96; TY2SYS-96 SERIES**

• **INSTALLATION**

• **OPERATION**

• **MAINTENANCE**



W164 N9221 Water Street • P.O. Box 450 • Menomonee Falls, Wisconsin 53052-0450 USA  
PHONE: 262.251.3800 • 800.558.8744 USA/CANADA FAX: 262.251.7067 • 800.329.8744 U.S.A. ONLY  
[www.alto-shaam.com](http://www.alto-shaam.com)

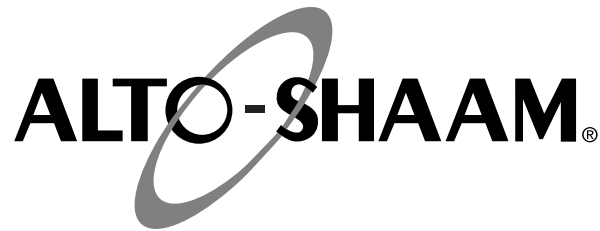

Delivery . . . . .	1
Unpacking . . . . .	1
Safety Procedures and Precautions . . . . .	2

**Installation**

Installation Requirements . . . . .	3
Clearance Requirements . . . . .	3
Leveling . . . . .	3
Cutting Board Installation . . . . .	3
Exterior Dimensions . . . . .	4
Electrical Connection . . . . .	5
Options & Accessories . . . . .	6

**Operating Instructions**

User Safety Information . . . . .	7
Start-up Operation . . . . .	7
Operating Procedures . . . . .	8
Pan Configurations . . . . .	9-11
General Holding Guidelines . . . . .	12

**Care and Cleaning**

Cleaning and Preventative Maintenance	
Protecting Stainless Steel Surfaces . . . . .	13
Cleaning Agents . . . . .	13
Cleaning Materials . . . . .	13
Equipment Care . . . . .	14
Clean the Probes . . . . .	14
Clean Daily . . . . .	14
Sanitation . . . . .	15

**Service**

TY2 Series, Countertop Assembly . . . . .	16-18
TY2 Series, Base Assembly . . . . .	19
TY2 Series, Inner Top Assembly . . . . .	20
Cable Replacement Kits . . . . .	21

**Wire Diagrams**

48 Series	
120/208-240V . . . . .	22
120/208-240V, w/ outlets, . . . . .	23
230V . . . . .	24
72 Series	
120/208-240V . . . . .	25
120/208-240V, w/ outlets, . . . . .	26
230V . . . . .	27
96 Series	
120/208-240V . . . . .	28
120/208-240V, w/ outlets, . . . . .	29
230V . . . . .	30
Deli Probe Display Optional Kit . . . . .	31

**Warranty**

Transportation Damage and Claims . . . . .	Back Cover
Limited Warranty . . . . .	Back Cover

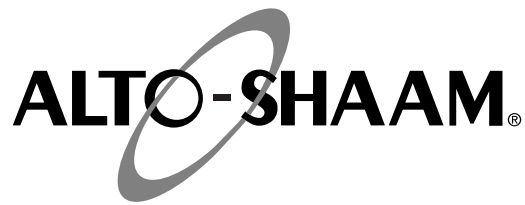

## DELIVERY

This Alto-Shaam appliance has been thoroughly tested and inspected to ensure only the highest quality unit is provided. Upon receipt, check for any possible shipping damage and report it at once to the delivering carrier. *See Transportation Damage and Claims section located in this manual.*

This appliance, complete with unattached items and accessories, may have been delivered in one or more packages. Check to ensure that all standard items and options have been received with each model as ordered.

Save all the information and instructions packed with the appliance. Complete and return the warranty card to the factory as soon as possible to ensure prompt service in the event of a warranty parts and labor claim.

This manual must be read and understood by all people using or installing the equipment model. Contact the Alto-Shaam Tech Team Service Department if you have any questions concerning installation, operation, or maintenance.

**NOTE:** All claims for warranty must include the full model number and serial number of the unit.

## UNPACKING

1. Carefully remove the appliance from the carton or crate.

**NOTE:** Do not discard the carton and other packaging material until you have inspected the unit for hidden damage and tested it for proper operation.

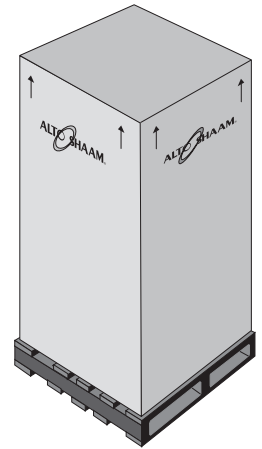

2. Read all instructions in this manual carefully before initiating the installation of this appliance.

**DO NOT DISCARD THIS MANUAL.**

This manual is considered to be part of the appliance and is to be provided to the owner or manager of the business or to the person responsible for training operators. *Additional manuals are available from the Alto-Shaam Tech Team Service Department.*

3. Remove all protective plastic film, packaging materials, and accessories from the appliance before connecting electrical power. Store any accessories in a convenient place for future use.

# SAFETY PROCEDURES AND PRECAUTIONS

Knowledge of proper procedures is essential to the safe operation of electrically and/or gas energized equipment. In accordance with generally accepted product safety labeling guidelines for potential hazards, the following signal words and symbols may be used throughout this manual.

<b>DANGER</b>	
	<b>Used to indicate the presence of a hazard that WILL cause severe personal injury, death, or substantial property damage if the warning included with this symbol is ignored.</b>

<b>WARNING</b>	
	<b>Used to indicate the presence of a hazard that CAN cause personal injury, possible death, or major property damage if the warning included with this symbol is ignored.</b>

<b>CAUTION</b>	
	<b>Used to indicate the presence of a hazard that can or will cause minor or moderate personal injury or property damage if the warning included with this symbol is ignored.</b>

<b>CAUTION</b>	
<b>Used to indicate the presence of a hazard that can or will cause minor personal injury, property damage, or a potential unsafe practice if the warning included with this symbol is ignored.</b>	

<b>NOTE:</b> Used to notify personnel of installation, operation, or maintenance information that is important but not hazard related.
--

1. This appliance is intended to cook, hold or process foods for the purpose of human consumption. No other use for this appliance is authorized or recommended.
2. This appliance is intended for use in commercial establishments where all operators are familiar with the purpose, limitations, and associated hazards of this appliance. Operating instructions and warnings must be read and understood by all operators and users.
3. Any troubleshooting guides, component views, and parts lists included in this manual are for general reference only and are intended for use by qualified technical personnel.
4. This manual should be considered a permanent part of this appliance. This manual and all supplied instructions, diagrams, schematics, parts lists, notices, and labels must remain with the appliance if the item is sold or moved to another location.

<b>NOTE</b>	
	<b>For equipment delivered for use in any location regulated by the following directive: DO NOT DISPOSE OF ELECTRICAL OR ELECTRONIC EQUIPMENT WITH OTHER MUNICIPAL WASTE.</b>

# INSTALLATION

## DANGER



IMPROPER INSTALLATION, ALTERATION, ADJUSTMENT, SERVICE, OR MAINTENANCE COULD RESULT IN SEVERE INJURY, DEATH, OR CAUSE PROPERTY DAMAGE.

READ THE INSTALLATION, OPERATING AND MAINTENANCE INSTRUCTIONS THOROUGHLY BEFORE INSTALLING OR SERVICING THIS EQUIPMENT.

## CAUTION



METAL PARTS OF THIS EQUIPMENT BECOME EXTREMELY HOT WHEN IN OPERATION. TO AVOID BURNS, ALWAYS USE HAND PROTECTION WHEN OPERATING THIS APPLIANCE.

## CAUTION



TO PREVENT PERSONAL INJURY, USE CAUTION WHEN MOVING OR LEVELING THIS APPLIANCE.

## SITE INSTALLATION

In order to maintain established National Sanitation Foundation standards, all stationary floor models must be sealed to the floor with a R.T.V. or silastic meeting N.S.F. requirements or have 6" (152mm) unobstructed clearance beneath the unit.

1. The appliance must be installed on a stable and level surface.
2. **DO NOT** install this appliance in any area where it may be affected by any adverse conditions such as steam, grease, dripping water, high temperatures, or any other severely adverse conditions.
3. **DO NOT** install a heated display case near a cold air source such as a freezer, air conditioning vents, or in any area where outside air fluctuation can affect performance.
4. This appliance must be kept free and clear of any obstructions blocking access for maintenance or service.

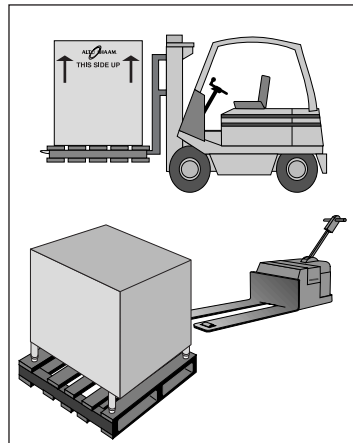

A number of adjustments are associated with initial installation and start-up. It is important that these adjustments be conducted by a qualified service technician. Installation and start-up adjustments are the responsibility of the dealer or user. These adjustments include but are not limited to thermostat calibration, door adjustment, leveling, electrical hook-up and installation of optional casters or legs.

## LEVELING



Level the appliance from side-to-side and front-to-back with the use of a spirit level.

We recommend checking the level periodically to make certain the floor has not shifted nor the appliance moved.

**NOTE:** Failure to properly level this appliance can cause improper function.

## Cutting board installation:

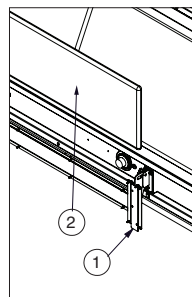

1. Place both brackets in the closed (down) position.
2. Slide cutting board back flanges down onto brackets.
3. Pivot installed board to a horizontal position and slide bracket down to lock in the open position. (NOT SHOWN)

## MINIMUM CLEARANCE REQUIREMENTS

Counter and table units must be mounted on legs of a sufficient 4" (102mm) or 6" (152mm) height depending on unit length to provide minimum unobstructed space beneath the unit. These legs are supplied with the unit. Warranty will become null and void if these directions are not followed.

# INSTALLATION

## EXTERIOR DIMENSIONS - TY2 & TY2SYS SERIES

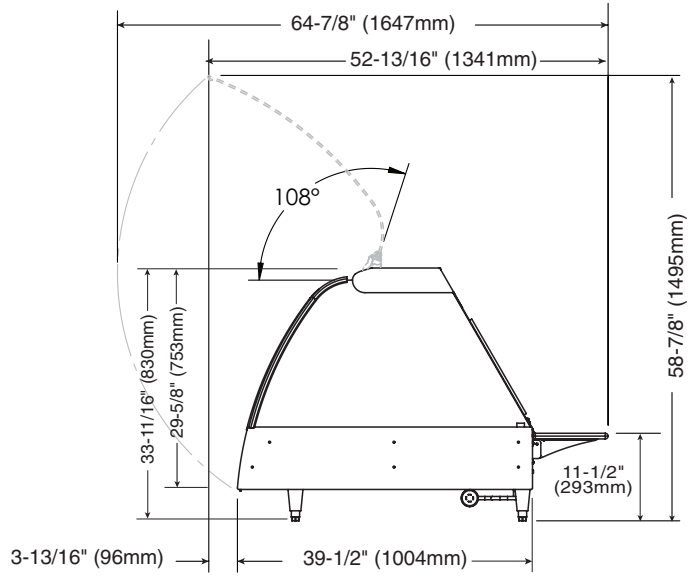
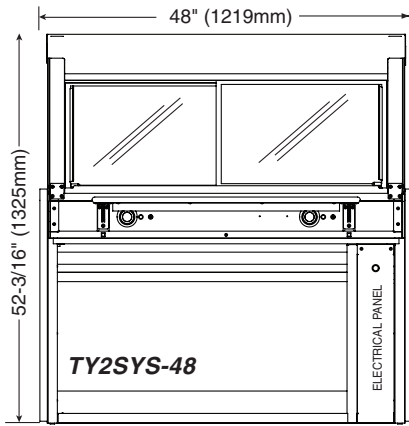

*TY2 Side Profile*

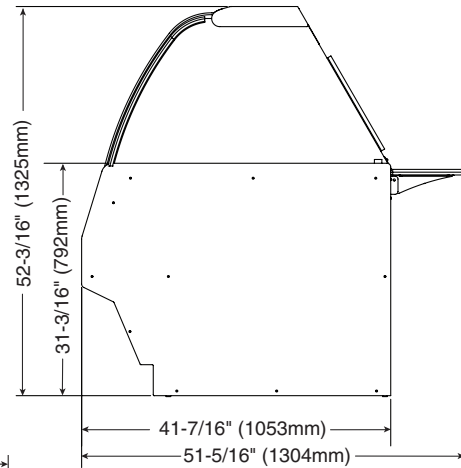
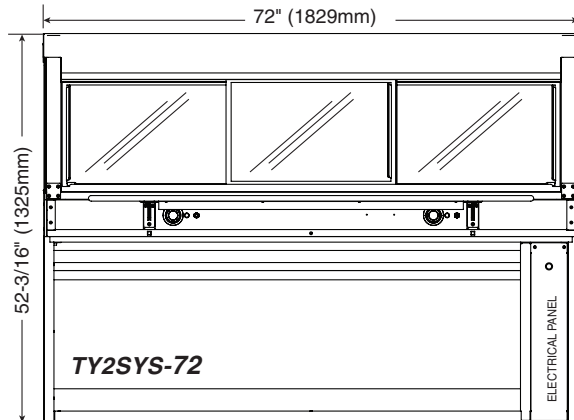

*TY2SYS Side Profile*

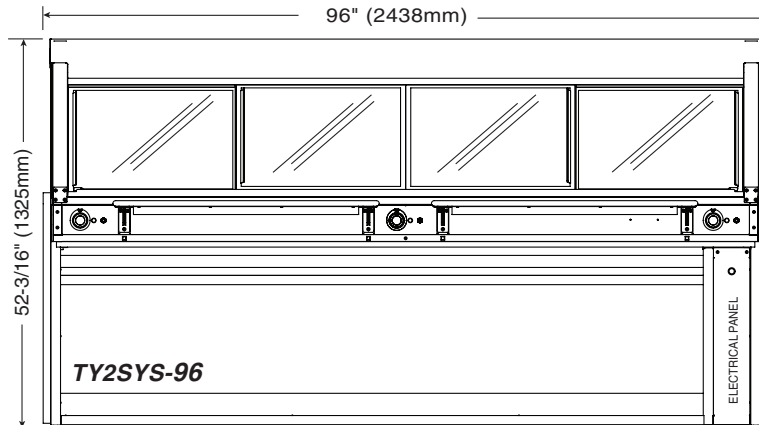

# INSTALLATION

## ELECTRICAL CONNECTION

The appliance must be installed by a qualified service technician. The oven must be properly grounded in accordance with the National Electrical Code and applicable local codes.

Proper receptacle or outlet configuration or permanent wiring for this unit must be installed by a licensed electrician in accordance with applicable local electrical codes.

### DANGER



**To avoid electrical shock, this appliance **MUST** be adequately grounded in accordance with local electrical codes or, in the absence of local codes, with the current edition of the National Electrical Code ANSI/NFPA No. 70. In Canada, all electrical connections are to be made in accordance with CSA C22.1, Canadian Electrical Code Part 1 or local codes.**



Plug the unit into a properly grounded receptacle **ONLY**, positioning the unit so that the plug is easily accessible in case of an emergency. Arcing will occur when connecting or disconnecting the unit unless all controls are in the "OFF" position.

### ⚠ DANGER



**ELECTRICAL CONNECTIONS MUST BE MADE BY A QUALIFIED SERVICE TECHNICIAN IN ACCORDANCE WITH APPLICABLE ELECTRICAL CODES.**

### ⚠ DANGER



**ENSURE POWER SOURCE MATCHES VOLTAGE STAMPED ON APPLIANCE NAMEPLATE.**

#### REGARDING INTERNATIONAL STANDARD UNITS:

If the unit is not equipped with flexible cord and plug, an all-pole country approved disconnection device which has a contact separation of at least 3mm in all poles must be incorporated in the fixed wiring for disconnection. When using a cord without a plug, the green/yellow conductor shall be connected to the terminal which is marked with the ground symbol. If a plug is used, the socket outlet must be easily accessible. If the power cord needs replacement, use a similar one obtained from the distributor.

**For CE approved units:** To prevent an electrical shock hazard between the appliance and other appliances or metal parts in close vicinity, an equalization-bonding stud is provided. An equalization bonding lead must be connected to this stud and the other appliances / metal parts to provide sufficient protection against potential difference. The terminal is marked with the following symbol.





#### Hard wired models:

Hard wired models must be equipped with a country certified external allpole disconnection switch with sufficient contact separation.

If a power cord is used for the connection of the product an oil resistant cord like H05RN or H07RN or equivalent must be used.

**NOTE:** CE approved appliances must be connected to an electrical circuit that is protected by an external GFCI outlet.

ELECTRICAL						
48 Series						
VOLTAGE	PHASE	CYCLE/HZ	AMPS	KW		
120/208-240 (AGCY)	1	50/60	13.8	3.3	NEMA L14-20P 20A, 250V PLUG	
AT 208	1	50/60	11.6	2.5		
AT 240	1	50/60	13.0	3.1		
230 (AGCY)	1	50	12.6	2.9	BARE END, NO PLUG	
230	1	50	12.6	2.9		
72 Series						
VOLTAGE	PHASE	CYCLE/HZ	AMPS	KW		
120/208-240 (AGCY)	1	50/60	18.75	4.5	NEMA L14-30P 30A, 250V PLUG	
AT 208	1	50/60	19.0	4.6		
AT 240	1	50/60	19.0	4.6		
230 (AGCY)	1	50	18.3	4.2	BARE END, NO PLUG	
230	1	50	18.4	4.2		
96 Series						
VOLTAGE	PHASE	CYCLE/HZ	AMPS	KW		
120/208-240 (AGCY)	1	50/60	24.0	5.2	NEMA L14-30P 30A, 250V PLUG	
AT 208	1	50/60	24.0	5.2		
AT 240	1	50/60	24.0	5.2		
230 (AGCY)	1	50	24.3	5.6	BARE END, NO PLUG	
230	1	50	24.7	5.7		

Wire diagrams are located in the literature package that came with the unit.

# INSTALLATION

## FACTORY INSTALLED OPTIONS

DESCRIPTION	TY2-48 SERIES	TY2-72 SERIES	TY2-96 SERIES
INDEPENDENT ELECTRICAL OUTLET	5001781	5001781	5001781
TEMPERATURE PROBE	5004916	5004917	5004918

## ACCESSORIES

DESCRIPTION	TY2-48 SERIES	TY2-72 SERIES	TY2-96 SERIES
BUTTING KIT (SEAMLESSLY CONNECT MULTIPLE SYSTEMS TOGETHER)	5009001	5009001	5009001
CARVING STATION	5001874	5001874	5001874
PAN INSERT, SELF SERVICE 4" (102mm) DEEP	1001990	1001991	—
PLATFORM SCALE	55265	55265	55265
SHEET PAN DIVIDER BAR PACKAGE	TY2-48, -48/P	5002802	—
	TY2-72, -72/P	—	5002803
	TY2-72/PL, -72/PR	—	5002804
	TY2-96	—	—
	TY2-96/PL, -96/PR	—	—
THERMOSTAT GUARD COVER PLATE	5007660 (2 REQ'D)	5007660 (2 REQ'D)	5007660 (3 REQ'D)
WORK SHELF WITH GRAVY LANE	TY2-48, -48/P	5005638	—
	TY2-72, -72/P, -72/PL, -72/PR	—	5005639
	TY2-96, -96/P, -96/PL, -96/PR	—	—
			5005640



# OPERATING INSTRUCTIONS

## USER SAFETY INFORMATION

### CAUTION



**METAL PARTS OF THIS EQUIPMENT BECOME EXTREMELY HOT WHEN IN OPERATION. TO AVOID BURNS, ALWAYS USE HAND PROTECTION WHEN OPERATING THIS APPLIANCE.**

The Alto-Shaam heated display case is intended for use in commercial establishments by qualified operating personnel where all operators are familiar with the purpose, limitations, and associated hazards of this appliance. Operating instructions and warnings must be read and understood by all operators and users.

### WARNING

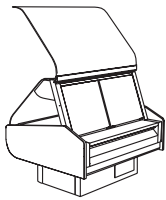

**Hood glass extended to the full, upright portion is stabilized through the use of gas struts designed for the full, load-bearing weight. These struts could weaken or fail due to wear, environmental conditions or aging. OPERATORS SHOULD BE AWARE OF ANY INCREASE IN EFFORT TO LIFT THE HOOD AND INITIATE AN IMMEDIATE GAS STRUT SAFETY CHECK. DO NOT LIFT THE HOOD IN THIS CONDITION.**

## START-UP OPERATION

### BEFORE INITIAL USE:

Interior display case surfaces must be heated to remove surface oils and the accompanying odor produced during the first use of the appliance.

Remove pans. Turn thermostats to the "ON" position. Set thermostats to the 10 setting. Allow the unit to heat for 30 minutes or until no odor is detected.

### PREHEATING:

The unit should be preheated at the 10 setting for a minimum of 30-45 minutes before loading the case with hot food. Follow the operating instructions indicated on the next page of this manual.



### DANGER



**DISCONNECT UNIT FROM POWER SOURCE BEFORE CLEANING OR SERVICING.**

### DANGER



**AT NO TIME SHOULD THE INTERIOR OR EXTERIOR BE STEAM CLEANED, HOSED DOWN, OR FLOODED WITH WATER OR LIQUID SOLUTION OF ANY KIND. DO NOT USE WATER JET TO CLEAN.**



**SEVERE DAMAGE OR ELECTRICAL HAZARD COULD RESULT.**

**WARRANTY BECOMES VOID IF APPLIANCE IS FLOODED**

# OPERATING INSTRUCTIONS

## OPERATING PROCEDURES

### 1. DO NOT ADD WATER TO DISPLAY CASE

Halo Heat display cases maintain a constant but gentle temperature and eliminate much of the moisture loss associated with conventional display cases. Because of this gentle heat, it is not necessary to add water to the display case. As a matter of fact, **adding water is not recommended** since water will accelerate the deterioration of the product, and may damage the unit voiding the warranty.

### 2. PLACE DIVIDERS AND SERVING PANS IN CASE

Refer to the pan layout diagrams for different types of pan accommodations. A complete pan configuration layout is located in this manual. **It is VERY important to note**, no matter what type of pan configuration chosen, pan separator bars or divider bars must be used to close all gaps between pans, and all gaps between the pans and the edges of the display case. If these gaps are not closed, heat will escape from the bottom of the case into the display area. As a consequence, heat distribution will be uneven and uniform temperature will be difficult to hold. If needed, additional pan divider bars are available. The supplied self-serve pan inserts with wire grids are for use with pre-packaged foods in the self-serve sections of the units.

### 3. TURN DISPLAY LIGHTS "ON" AND SET THE THERMOSTAT(S) AT NUMBER "10" TO PREHEAT

A indicator light will illuminate when the thermostat(s) is (are) turned "ON." The indicator(s) will remain lit as long as the unit is preheating or calling for heat. The unit should be preheated at the 10 setting for a minimum of 30-45 minutes before loading the case with hot food. When preheating is completed, or whenever the unit reaches any temperature set by the operator between 1 and 10, the indicator light(s) will go "OUT".

### 4. LOAD HOT FOODS INTO DISPLAY CASE

Be certain only hot food is transferred into the display case. Before loading food into the case, use a pocket-type meat thermometer to make certain all products have reached an internal temperature of 140° to 160° F (60° to 71°C). If any food product is not at proper serving temperature, use a Halo Heat cooking and holding oven, set at 250° to 275°F (121° to 135°C), or a Combitherm oven to bring the product within the correct temperature range.

- Use hand protection when handling hot items.
- Be certain only hot PREPACKAGED foods in appropriate heat tested containers are used in the self-service section of the display case.
- Do not stack food containers.

### 5. RESET THERMOSTAT(S) AS NEEDED

After all products are loaded into the display case and the doors are closed, it is necessary to reset the thermostat(s). For fully enclosed sections, reset the thermostat to the number "8" setting. Cases with a self-service section should be maintained between number "9" and number "10" for the self-service section **only**. THESE SETTINGS WILL NOT NECESSARILY BE FINAL. Since proper temperature range depends on the type of products and the quantities being held, it is necessary to periodically use a pocket thermometer to check each item to make certain the correct temperatures are being maintained. Proper temperature range is between a minimum of 140° and 160°F (60° and 71°C). Normally, this will require a thermostat setting of between number "6" and "8" in fully enclosed cases. Self-service cases or sections will always require a higher thermostat setting.

### 6. PLACEMENT OF FOOD PROBE

If the unit is equipped with the probe accessory, wipe each probe and probe tip with a disposable alcohol pad to clean and sanitize before using. If the probe is left in its bracket, the LED temperature display will indicate the ambient air temperature inside the case. To place a probe into food kept in the case, remove the probe from the bracket and push the probe tip halfway into the product, positioning the tip at the center of the food mass. If placing into solid foods such as meat roast or poultry breasts, push the probe in from a straight downward position or in from the side to the center position. If placing into a semi-liquid or liquid product, the probe cable will probably need to be secured to keep the probe positioned properly. Do not let the probe tip touch the edges or sides. Tape the probe cable to the lip or edge of the container. Wipe each probe tip with a clean paper towel to remove food debris after each use. Follow by wiping probes with a disposable alcohol pad, and return each probe to the proper bracket position.

### 7. SERVE FRESH HOT FOOD

Keep hot foods looking fresh. Occasionally stir or rotate food as needed. Serve food products in appropriate heat tested packages or containers. Keep display case doors closed after serving. Wipe spills immediately to assure maximum eye appeal and to ease end of the day cleanup.



# OPERATING INSTRUCTIONS

## PAN CONFIGURATIONS • SELF-SERVE HEATED DISPLAY CASES

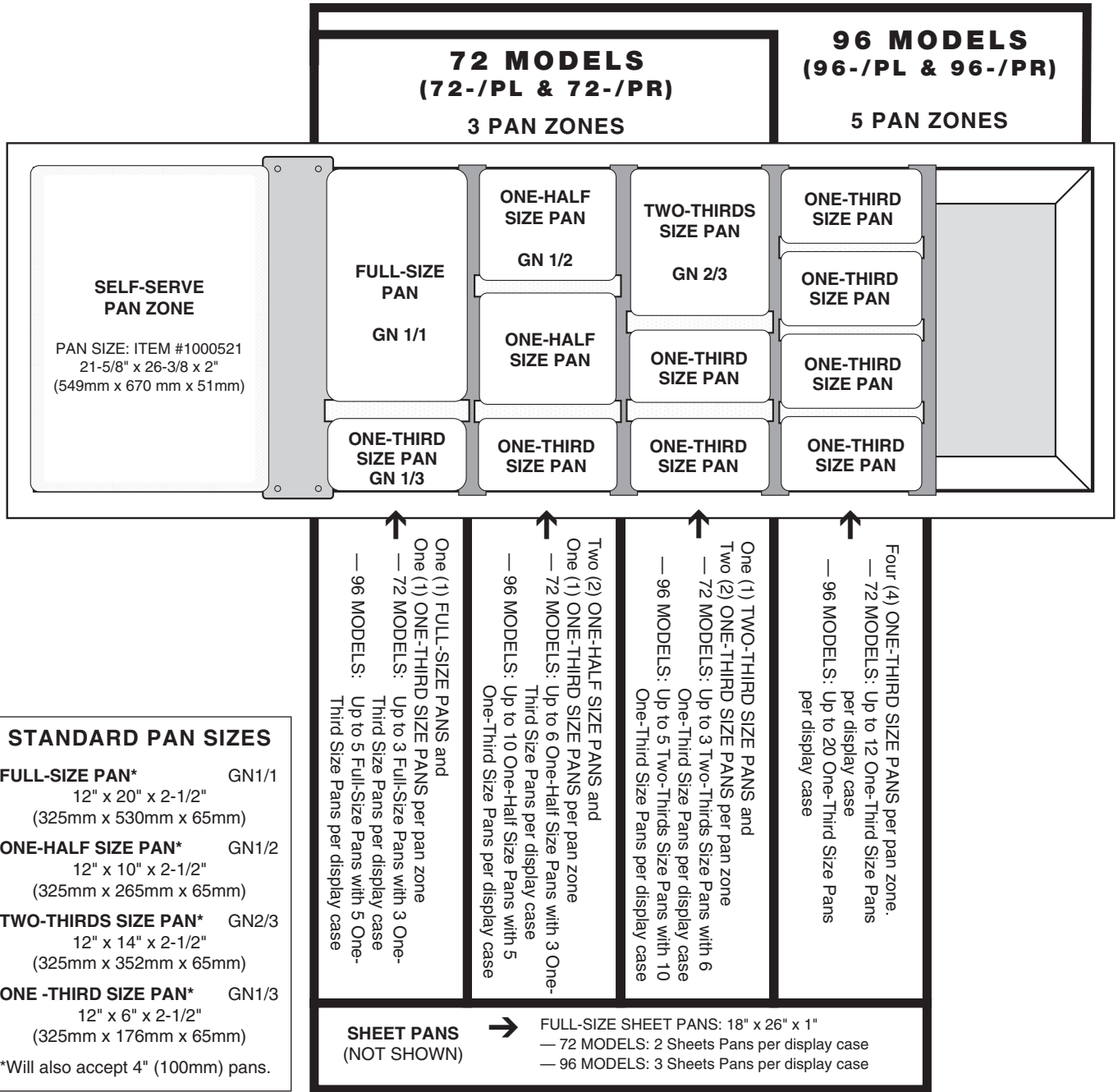

### STANDARD PAN DIVIDER AND SEPARATOR BARS

PART NO.	DESCRIPTION	DIMENSIONS (W x L)	72	96
1002584	FULL, HALF AND THIRD SIZE-LONG	2-1/2" x 28" (64mm x 711mm)	4	—
1002590	FULL, HALF AND THIRD SIZE-LONG	1-13/16" x 28" (46mm x 711mm)	—	6
1002621	FULL, HALF AND THIRD SIZE-SHORT	1-15/32" x 13-1/2" (37mm x 343mm)	5	7
11318	FULL, HALF AND THIRD SIZE-SHORT	1" x 13-1/2" (25mm x 343mm)	15	21

# OPERATING INSTRUCTIONS

## INTERNATIONAL PAN DIVIDER KITS

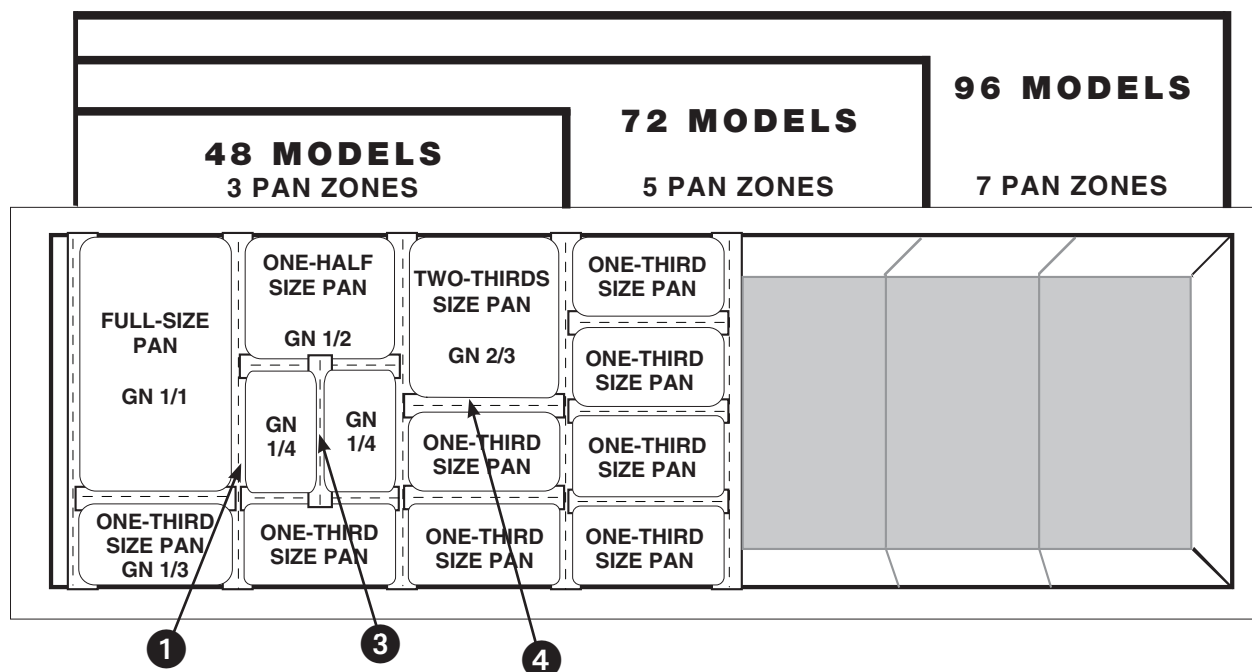

MODEL >	48		72		96	
DESCRIPTION	PART NO.	QTY	PART NO.	QTY	PART NO.	QTY
INTERNATIONAL PAN DIVIDER KIT	5009135	1	5009136	1	5009137	1

BARS INCLUDED IN EACH KIT						
	PART NO.	DESCRIPTION	DIMENSIONS (W x L)	48	72	96
①	1002585	GN 1/1, GN 1/2, GN 1/3 - Long	58 mm x 711 mm	4	4	—
②	1002591*	GN 1/1, GN 1/2, GN 1/3 - Long	41 mm x 711 mm	—	—	6
③	1002619	GN 1/4	25 mm x 270 mm	6	10	14
④	1000544	GN 1/1, GN 1/2, GN 1/3 - Short	25 mm x 327 mm	9	15	21

\*NOT SHOWN.

### STANDARD PAN SIZES

FULL-SIZE PAN*	GN1/1	12" x 20" x 2-1/2" (325mm x 530mm x 65mm)
ONE-HALF SIZE PAN*	GN1/2	12" x 10" x 2-1/2" (325mm x 265mm x 65mm)
TWO-THIRDS SIZE PAN*	GN2/3	12" x 14" x 2-1/2" (325mm x 352mm x 65mm)
ONE -THIRD SIZE PAN*	GN1/3	12" x 6" x 2-1/2" (325mm x 176mm x 65mm)

\*Will also accept 4" (100mm) pans.

# OPERATING INSTRUCTIONS

## GENERAL HOLDING GUIDELINES

Chefs, cooks and other specialized food service personnel employ varied methods of cooking. Proper holding temperatures for a specific food product must be based on the moisture content of the product, product density, volume, and proper serving temperatures. Safe holding temperatures must also be correlated with palatability in determining the length of holding time for a specific product.

Halo Heat maintains the maximum amount of product moisture content without the addition of water, water vapor, or steam. Maintaining maximum natural product moisture preserves the natural flavor of the product and provides a more genuine taste. In addition to product moisture retention, the gentle properties of Halo Heat maintain a consistent temperature throughout the cabinet without the necessity of a heat distribution fan, thereby preventing further moisture loss due to evaporation or dehydration.

When product is removed from a high temperature cooking environment for immediate transfer into equipment with the lower temperature required for hot food holding, condensation can form on the outside of the product and on the inside of plastic containers used in self-service applications. Allowing the product to release the initial steam and heat produced by high temperature cooking can alleviate this condition. To preserve the safety and quality of freshly cooked foods however, a maximum of 1 to 2 minutes must be the only time period allowed for the initial heat to be released from the product.

The unit is equipped with a thermostat indicating a range of between 1 and 10. Use a metal-stemmed indicating thermometer to measure the internal temperature of the product(s) being held. Adjust the thermostat setting to achieve the best overall setting based on internal product temperature.

HOLDING TEMPERATURE RANGE		
MEAT	FAHRENHEIT	CELSIUS
BEEF ROAST — Rare	130°F	54°C
BEEF ROAST — Med/Well Done	155°F	68°C
BEEF BRISKET	160° — 175°F	71° — 79°C
CORN BEEF	160° — 175°F	71° — 79°C
PASTRAMI	160° — 175°F	71° — 79°C
PRIME RIB — Rare	130°F	54°C
STEAKS — Broiled/Fried	140° — 160°F	60° — 71°C
RIBS — Beef or Pork	160°F	71°C
VEAL	160° — 175°F	71° — 79°C
HAM	160° — 175°F	71° — 79°C
PORK	160° — 175°F	71° — 79°C
LAMB	160° — 175°F	71° — 79°C
POULTRY		
CHICKEN — Fried/Baked	160° — 175°F	71° — 79°C
DUCK	160° — 175°F	71° — 79°C
TURKEY	160° — 175°F	71° — 79°C
GENERAL	160° — 175°F	71° — 79°C
FISH/SEAFOOD		
FISH — Baked/Fried	160° — 175°F	71° — 79°C
LOBSTER	160° — 175°F	71° — 79°C
SHRIMP — Fried	160° — 175°F	71° — 79°C
BAKED GOODS		
BREADS/ROLLS	120° — 140°F	49° — 60°C
MISCELLANEOUS		
CASSEROLES	160° — 175°F	71° — 79°C
DOUGH — Proofing	80° — 100°F	27° — 38°C
EGGS — Fried	150° — 160°F	66° — 71°C
FROZEN ENTREES	160° — 175°F	71° — 79°C
HORS D'OEUVRES	160° — 180°F	71° — 82°C
PASTA	160° — 180°F	71° — 82°C
PIZZA	160° — 180°F	71° — 82°C
POTATOES	180°F	82°C
PLATED MEALS	140° — 165°F	60° — 74°C
SAUCES	140° — 200°F	60° — 93°C
SOUP	140° — 200°F	60° — 93°C
VEGETABLES	160° — 175°F	71° — 79°C
<b>THE HOLDING TEMPERATURES LISTED ARE SUGGESTED GUIDELINES ONLY. ALL FOOD HOLDING SHOULD BE BASED ON INTERNAL PRODUCT TEMPERATURES. ALWAYS FOLLOW LOCAL HEALTH (HYGIENE) REGULATIONS FOR ALL INTERNAL TEMPERATURE REQUIREMENTS.</b>		



# CARE AND CLEANING

## CLEANING AND PREVENTIVE MAINTENANCE

### PROTECTING STAINLESS STEEL SURFACES



It is important to guard against corrosion in the care of stainless steel surfaces. Harsh, corrosive, or inappropriate chemicals can completely destroy the protective surface layer of stainless steel. Abrasive pads, steel wool, or metal implements will abrade surfaces causing damage to this protective coating and will eventually result in areas of corrosion. Even water, particularly hard water that contains high to moderate concentrations of chloride, will cause oxidation and pitting that result in rust and corrosion. In addition, many acidic foods spilled and left to remain on metal surfaces are contributing factors that will corrode surfaces.



Proper cleaning agents, materials, and methods are vital to maintaining the appearance and life of this appliance. Spilled foods should be removed and the area wiped as soon as possible but at the very least, a minimum of once a day. Always thoroughly rinse surfaces after using a cleaning agent and wipe standing water as quickly as possible after rinsing.

### CLEANING AGENTS

Use non-abrasive cleaning products designed for use on stainless steel surfaces. Cleaning agents must be chloride-free compounds and must not contain quaternary salts. Never use hydrochloric acid (muriatic acid) on stainless steel surfaces. Always use the proper cleaning agent at the manufacturer's recommended strength. Contact your local cleaning supplier for product recommendations.

### CLEANING MATERIALS

The cleaning function can usually be accomplished with the proper cleaning agent and a soft, clean cloth. When more aggressive methods must be employed, use a non-abrasive scouring pad on difficult areas and make certain to scrub with the visible grain of surface metal to avoid surface scratches. Never use wire brushes, metal scouring pads, or scrapers to remove food residue.

 <b>CAUTION</b>	
	<b>TO PROTECT STAINLESS STEEL SURFACES, COMPLETELY AVOID THE USE OF ABRASIVE CLEANING COMPOUNDS, CHLORIDE BASED CLEANERS, OR CLEANERS CONTAINING QUATERNARY SALTS. NEVER USE HYDROCHLORIC ACID (MURIATIC ACID) ON STAINLESS STEEL. NEVER USE WIRE BRUSHES, METAL SCOURING PADS OR SCRAPERS.</b>
	
	

# CARE AND CLEANING

## EQUIPMENT CARE

Under normal circumstances, this appliance should provide you with long and trouble free service. There is no preventative maintenance required, however, the following Equipment Care Guide will maximize the potential life and trouble free operation of this appliance. The cleanliness and appearance of this equipment will contribute considerably to operating efficiency and savory, appetizing food. Good equipment that is kept clean works better and lasts longer.



## CLEAN THE PROBES DAILY

If the display case is supplied with probes, remove all food soil from probes. Wipe entire probe and cable assembly with warm detergent solution and a clean cloth. Remove detergent by wiping each probe and cable with clean rinse water and a cloth. Wipe probes with disposable alcohol pad or sanitizing solution recommended for food contact surfaces. Allow probe and cable to air dry in probe holding bracket.



## CLEAN DAILY

- Turn lights and adjustable thermostat(s) to the "OFF" position, and disconnect unit from power source.
- Remove, cover or wrap, and store unused products under refrigeration.
- Clean the interior metal surfaces of the cabinet with a damp clean cloth and any good commercial detergent or grease solvent at the recommended strength. Use a plastic scouring pad or oven cleaner for difficult areas. Rinse well to remove all residue and wipe dry.

**NOTE:** Avoid the use of abrasive cleaning compounds, chloride based cleaners, or cleaners containing quaternary salts. Never use hydrochloric acid (muriatic acid) on stainless steel.

- Clean the glass with a window cleaner. The sliding glass doors are removable allowing for easier cleaning.
- To help maintain the protective film coating on polished stainless steel, clean the exterior of the unit with a cleaner recommended for stainless steel surfaces. Spray the cleaning agent on a clean cloth and wipe with the grain of the stainless steel.

Always follow appropriate state or local health (hygiene) regulations regarding all applicable cleaning and sanitation requirements for equipment.

## CHECK OVERALL CONDITION ONCE A MONTH

Check the case and related cabinets once a month for physical damage and loose screws. Correct any problems before they begin to interfere with the operation of the unit.

## DO NOT USE APPLIANCE IF CONTROLS ARE NOT PROPERLY FUNCTIONING

Refer to the Trouble Shooting Guide located in this manual or call an authorized service technician.

# DANGER



AT NO TIME SHOULD THE INTERIOR OR EXTERIOR BE STEAM CLEANED, HOSED DOWN, OR FLOODED WITH WATER OR LIQUID SOLUTION OF ANY KIND. DO NOT USE WATER JET TO CLEAN.



**SEVERE DAMAGE OR ELECTRICAL HAZARD COULD RESULT.**

**WARRANTY BECOMES VOID IF APPLIANCE IS FLOODED**

# WARNING



Hood glass extended to the full, upright portion is stabilized through the use of gas struts designed for the full, load-bearing weight. These struts could weaken or fail due to wear, environmental conditions or aging. OPERATORS SHOULD BE AWARE OF ANY INCREASE IN EFFORT TO LIFT THE HOOD AND INITIATE AN IMMEDIATE GAS STRUT SAFETY CHECK. DO NOT LIFT THE HOOD IN THIS CONDITION.

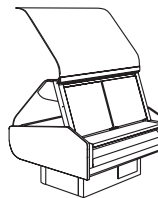

# CAUTION



The performance of this unit has been optimized using the factory provided bulbs. These bulbs should be replaced with an exact replacement or with a factory recommended replacement. These bulbs have been treated to resist breakage and must be replaced with similarly treated bulbs in order to maintain compliance with NSF standards. **DO NOT** over-tighten bulbs in their receptacles as this can cause damage to the bulb filament.



Food flavor and aroma are usually so closely related that it is difficult, if not impossible, to separate them. There is also an important, inseparable relationship between cleanliness and food flavor. Cleanliness, top operating efficiency, and appearance of equipment contribute considerably to savory, appetizing foods. Good equipment that is kept clean, works better and lasts longer.

Most food imparts its own particular aroma and many foods also absorb existing odors. Unfortunately, during this absorption there is no distinction between GOOD and BAD odors. The majority of objectionable flavors and odors troubling food service operations are caused by bacteria growth. Sourness, rancidity, mustiness, stale or other OFF flavors are usually the result of germ activity.

The easiest way to insure full, natural food flavor is through comprehensive cleanliness. This means good control of both visible soil (dirt) and invisible soil (germs). A thorough approach to sanitation will provide essential cleanliness. It will assure an attractive appearance of equipment, along with maximum efficiency and utility. More importantly, a good sanitation program provides one of the key elements in the prevention of food-borne illnesses.

A controlled holding environment for prepared foods is just one of the important factors involved in the prevention of food-borne illnesses. Temperature monitoring and control during receiving, storage, preparation, and the service of foods are of equal importance.

The most accurate method of measuring safe temperatures of both hot and cold foods is by internal product temperature. A quality thermometer is an effective tool for this purpose, and should be routinely used on all products that require holding at a specific temperature.

A comprehensive sanitation program should focus on the training of staff in basic sanitation procedures. This includes personal hygiene, proper handling of raw foods, cooking to a safe internal product temperature, and the routine monitoring of internal temperatures from receiving through service.

Most food-borne illnesses can be prevented through proper temperature control and a comprehensive program of sanitation. Both these factors are important to build quality service as the foundation of customer satisfaction. Safe food handling practices to prevent food-borne illness is of critical importance to the health and safety of your customers.

HACCP, an acronym for Hazard Analysis (at) Critical Control Points, is a quality control program of operating procedures to assure food integrity, quality, and safety. Taking steps necessary to augment food safety practices is both cost effective and relatively simple. While HACCP guidelines go far beyond the scope of this manual, additional information is available by contacting:

**CENTER FOR FOOD SAFETY AND APPLIED  
NUTRITION FOOD AND DRUG ADMINISTRATION  
1-888-SAFEFOOD**

INTERNAL FOOD PRODUCT TEMPERATURES		
<b>HOT FOODS</b>		
DANGER ZONE	40° TO 140°F	(4° TO 60°C)
CRITICAL ZONE	70° TO 120°F	(21° TO 49°C)
SAFE ZONE	140° TO 165°F	(60° TO 74°C)
<b>COLD FOODS</b>		
DANGER ZONE	ABOVE 40°F	(ABOVE 4°C)
SAFE ZONE	36° TO 40°F	(2° TO 4°C)
<b>FROZEN FOODS</b>		
DANGER ZONE	ABOVE 32°F	(ABOVE 0°C)
CRITICAL ZONE	0° TO 32°F	(-18° TO 0°C)
SAFE ZONE	0°F or below	(-18°C or below)

# SERVICE

## TY2(SYS) SERIES - COUNTERTOP ASSEMBLY (TY2-96 SHOWN)

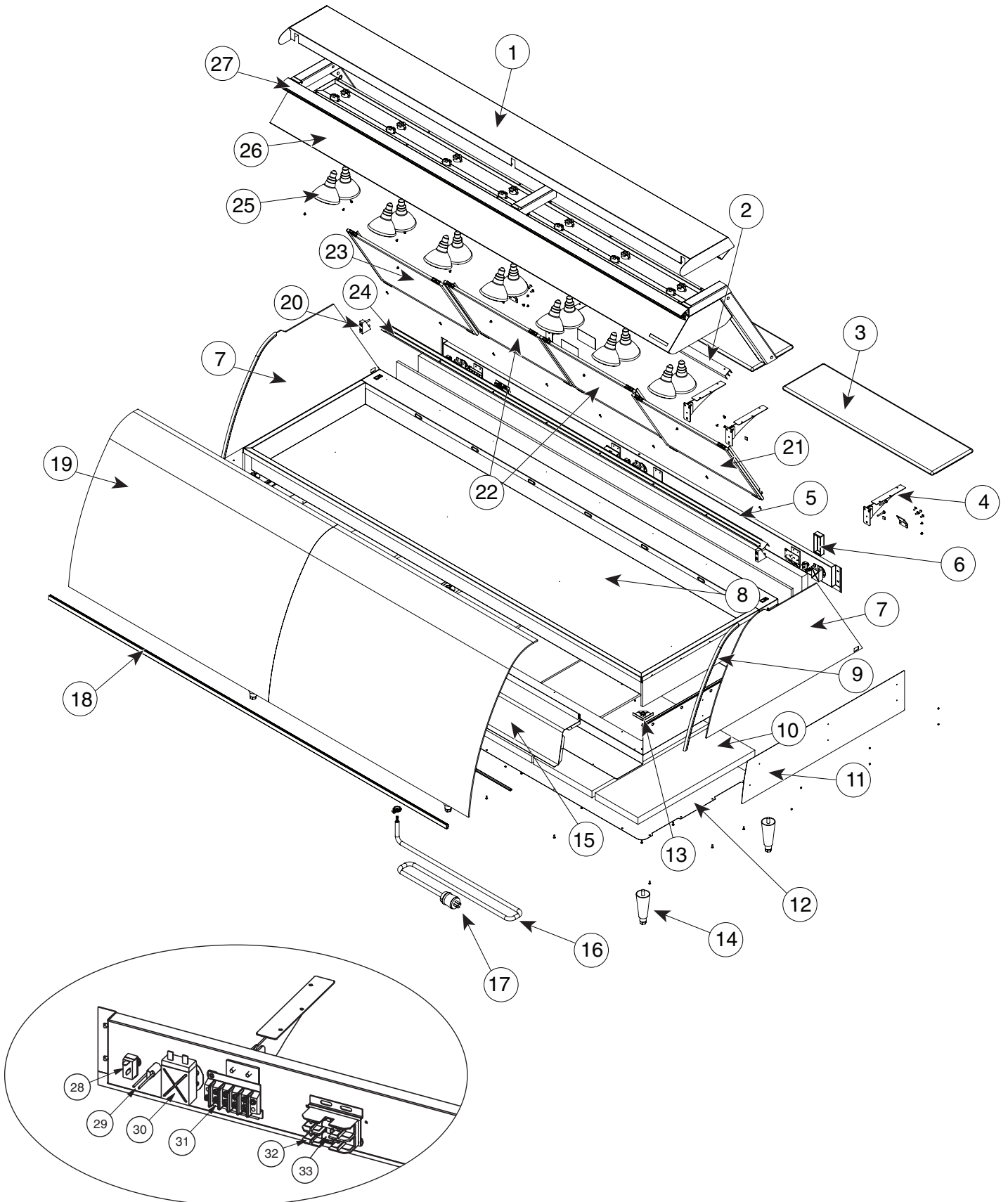

# SERVICE

MODEL >		TY2(SYS)-48		TY2(SYS)-72		TY2(SYS)-96	
ITEM	DESCRIPTION	PART NO.	QTY	PART NO.	QTY	PART NO.	QTY
1	OUTER TOP ASSEMBLY	5001737	1	5001950	1	5001951	1
2	DOOR TRACK, UPPER	TK-26752	1	TK-26754	1	TK-26756	1
3	CUTTING BOARD	4016	1	—	—	4016	2
	4ft (1.22m)	—	—	—	—	—	—
	6ft (1.83m)	—	—	4017	1	—	—
4	CUTTING BOARD BRACKET	BT-2342	2	BT-2342	2	BT-2342	2
5	CONTROL PANEL ASSEMBLY	5000247	1	5000635	1	5000880	1
6	BRACKET, CUTTING BOARD	11283	2	11283	2	11283	2
7	END GLASS	GL-26035	2	GL-26035	2	GL-26035	2
	CLEAR	GL-26777	1	GL-26777	1	GL-26777	1
	SOLAR BRONZE (LH)	GL-26778	1	GL-26778	1	GL-26778	1
	SOLAR BRONZE (RH)	GL-26778	1	GL-26778	1	GL-26778	1
8	WELL CABLE ASSEMBLY	5003844	1	5003845	1	5000880	1
9	GASKET, END GLASS	GS-22547	1	GS-22547	1	GS-22547	1
10	INSULATION	IN-22364	1	IN-22364	1	IN-22364	1
11	END PANEL	OP-26905	2	OP-26905	2	OP-26905	2
	BLACK (RH/LH)	1002703	1	1002703	1	1002703	1
	STAINLESS STEEL (RH)	1002704	1	1002704	1	1002704	1
	STAINLESS STEEL (LH)	1005753	2	1005753	2	1005753	2
	CUSTOM COLOR	1000260	1	1001624	1	1001469	1
12	ACCESS COVER	1000260	1	1001624	1	1001469	1
13	LEG BRACE WELD	5001830	1	5001830	1	5001830	1
14	LEGS	LG-22341	4	LG-22341	4	LG-22341	4
	4" (102mm)	1002486	1	1002759	1	1002760	1
15	FRONT DECOR PANEL	1002486	1	1002759	1	1002760	1
16	CORD 7" (2133mm)	CD-3291	1	CD-3557	1	CD-3557	1
	120V	CD-33490	1	CD-33490	1	CD-33490	1
	230V	CD-33490	1	CD-33490	1	CD-33490	1
17	PLUG	PG-3337	1	—	—	—	—
	NEMA L14-20P, 20A 250	—	—	PG-3267	1	PG-3267	1
	NEMA L14-30P, 30A 250	—	—	PG-3267	1	PG-3267	1
18	HANDLE	HD-27795	1	HD-27796	1	HD-27797	1
19	FRONT GLASS**	GL-22477	1	GL-22478	1	GL-22477	2
20	UPRIGHT WEDGE	BK-26061	2	BK-26061	2	BK-26061	2
21	DOOR GLASS, LEFT-HAND	DR-25422	1	DR-25422	1	DR-25422	1
22	DOOR GLASS, MIDDLE	DR-25423	1	DR-25423	1	DR-25423	2
23	DOOR GLASS, RIGHT-HAND	—	—	DR-25424	1	DR-25424	1
24	DOOR TRACK, BOTTOM	TK-26751	1	TK-26751	1	TK-26751	1
25	BULB	LP-33592	6	LP-33592	10	LP-33592	14
	120V	LP-33783	6	LP-33783	10	LP-33783	14
	230V	LP-33783	6	LP-33783	10	LP-33783	14
26	INNER TOP ASSEMBLY (SEE PAGE 19)	5001734	1	5001941	1	5001945	1
27	CLAMP ASSEMBLY	CM-26095	1	CM-26099	1	CM-26100	1
28	SWITCH, TOGGLE	SW-33896	2	SW-33896	2	SW-33896	3
	120V/208-240V	SW-3528	2	SW-3528	2	SW-3528	3
	230V	SW-3905	2	SW-3905	2	SW-3905	3
	230V	SW-3905	2	SW-3905	2	SW-3905	3
29	INDICATOR LIGHT	LI-3951	2	LI-3027	2	LI-3027	3
	120V/208-240V	LI-3951	2	LI-3951	2	LI-3951	3
	230V	LI-3951	2	LI-3951	2	LI-3951	3
30	THERMOSTAT	TT-3498	2	TT-3498	2	TT-3498	3
31	TERMINAL BLOCK	BK-25432	1	BK-25432	1	BK-25432	1
32	FUSE HOLDER	FU-3772	1	FU-3772	1	FU-3772	1
33	FUSE, 15 AMP	FU-3775	2	FU-3775	2	FU-3775	2
34*	THERMOSTAT KNOB	KN-3473	2	KN-3473	2	KN-3473	3

\* NOT SHOWN

\*\* See substitute parts section for self-service units (pg 18)

# SERVICE

## SUBSTITUTE PARTS FOR SELF-SERVE UNITS

* NOT SHOWN		MODEL >	TY2(SYS)	-48/P	-72/P	-72/PL, /PR	-96/PL, /PR
ITEM	DESCRIPTION		PART NO.	QTY	QTY	QTY	QTY
1	PAN GRIDS		PN-25752	2	3	1	1
2	PAN INSERT		1000993	1	—	—	—
			1000735	—	1	—	—
			1000521	—	—	1	1
3	GLASS FRONT	FULL-SERVE	GL-22477	—	—	1	—
			GL-22478	—	—	—	1
		SELF-SERVE	GL-22475	1	—	—	—
			GL-22476	—	1	—	—
			GL-22474	—	—	1	1
4	TEMPERED GLASS DIVIDER		GL-22049	—	—	1	1
5*	DIVIDER GLASS SUPPORT		5002164	—	—	1	—
			5002165	—	—	—	1
6	GUARD, HEAT ASSEMBLY		5013006	1	—	—	—
			5013007	—	1	—	—
			5013008	—	—	1	1
7*	GUARD, HEAT (PRIOR TO 01/11)		GD-25577	1	—	—	—
			GD-25899	—	1	—	—
			GD-24852	—	—	1	1
8*	HOLDER, HEAT GUARD (PRIOR TO 01/11)		1000734	1	—	—	—
			1002065	—	1	—	—
			1001455	—	—	1	1
9*	STRUT, GAS	500N	SU-24829	—	2	2	2
		800N	SU-24830	—	—	1	1

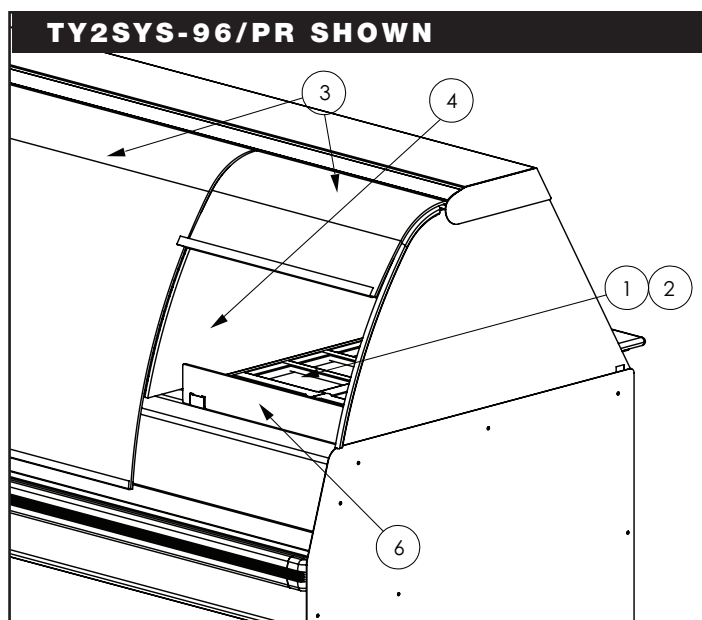

## TY2(SYS) SERIES - BASE ASSEMBLY (TY2SYS-96 SHOWN)

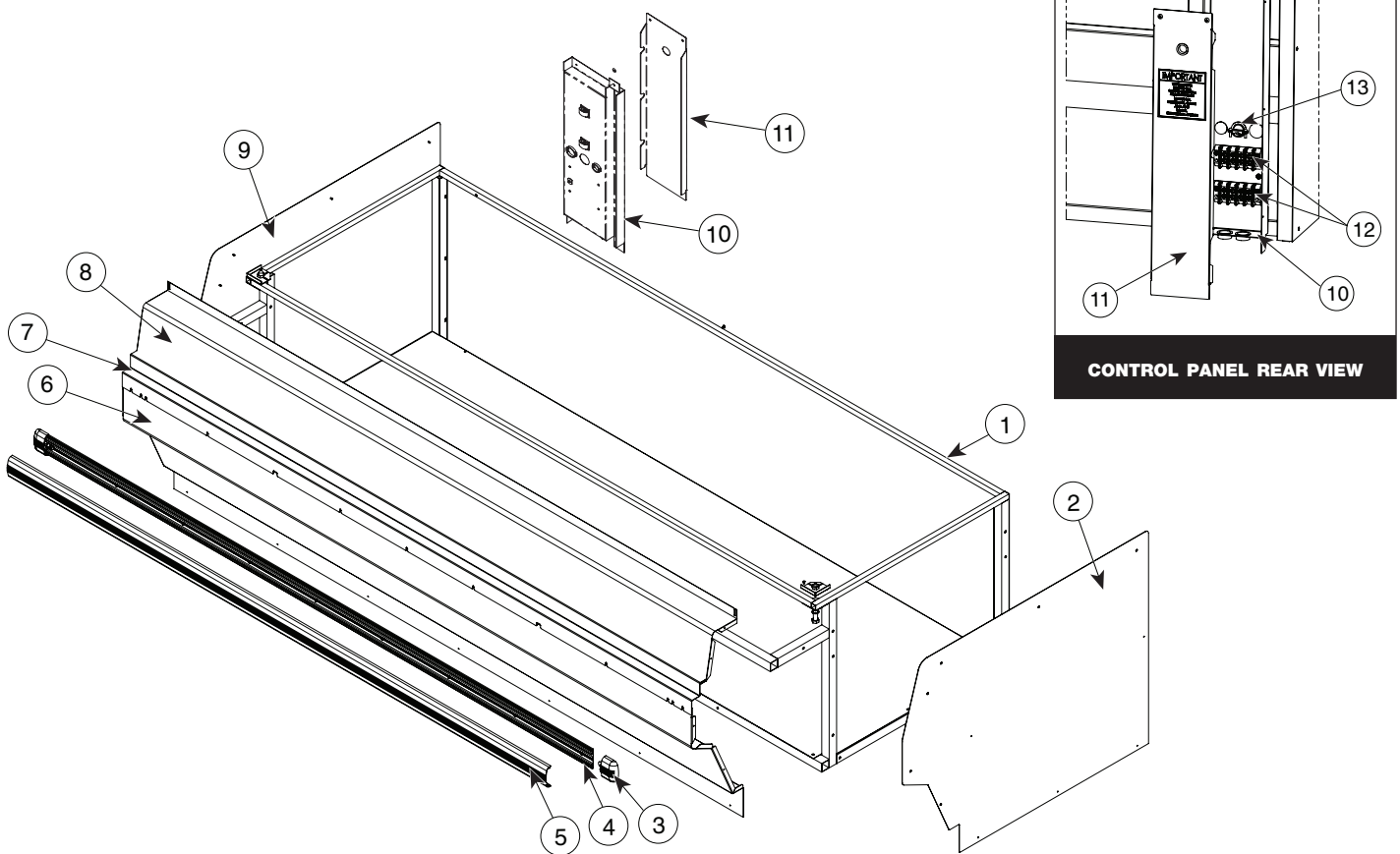

MODEL >		TY2(SYS)-48		TY2(SYS)-72		TY2(SYS)-96	
ITEM	DESCRIPTION	PART NO.	QTY	PART NO.	QTY	PART NO.	QTY
1	FRAME WELD	FR-26296	1	FR-26297	1	FR-26298	1
2	END PANEL, RH	BLACK	OP-26906	OP-26906	1	OP-26906	1
		STAINLESS STEEL	1003568	1003568	1	1003568	1
		CUSTOM COLOR	1005754	1005754	1	1005754	1
3	BUMPER, END CAP	BM-29064	2	BM-29064	2	BM-29064	2
4	BUMPER TRACK	1010949	1	1010950	1	1010951	1
5	BUMPER RAIL	4ft (1.22m)	1010952	—	—	—	—
		6ft (1.83m)	—	1010953	1	—	—
		8ft (2.44m)	—	—	—	1010954	1
6	FRONT PANEL, LOWER	BLACK	OP-26907	OP-26908	1	OP-26909	1
		STAINLESS STEEL	1003569	1003570	1	1003571	1
		CUSTOM COLOR	1004830	1004831	1	1004832	1
7	FRONT PANEL, UPPER	1003860	1	1003861	1	1003860	1
8	FRONT DECOR PANEL	1002486	1	1002759	1	1002760	1
9	END PANEL, LH	BLACK	OP-26906	OP-26906	1	OP-26906	1
		STAINLESS STEEL	1003567	1003567	1	1003567	1
		CUSTOM COLOR	1005754	1005754	1	1005754	1
10	ELECTRICAL PANEL	1003602	1	1003602	1	1003602	1
11	ACCESS PANEL	1003603	1	1003603	1	1003603	1
12	TERMINAL BLOCK	BK-3023	2	BK-3023	2	BK-3023	2
13	3/4" CORD CONNECTOR	CR-3293	1	CR-3293	1	CR-3293	1

# SERVICE

## TY2(SYS) SERIES - INNER TOP ASSEMBLY (TY2-96 SHOWN)

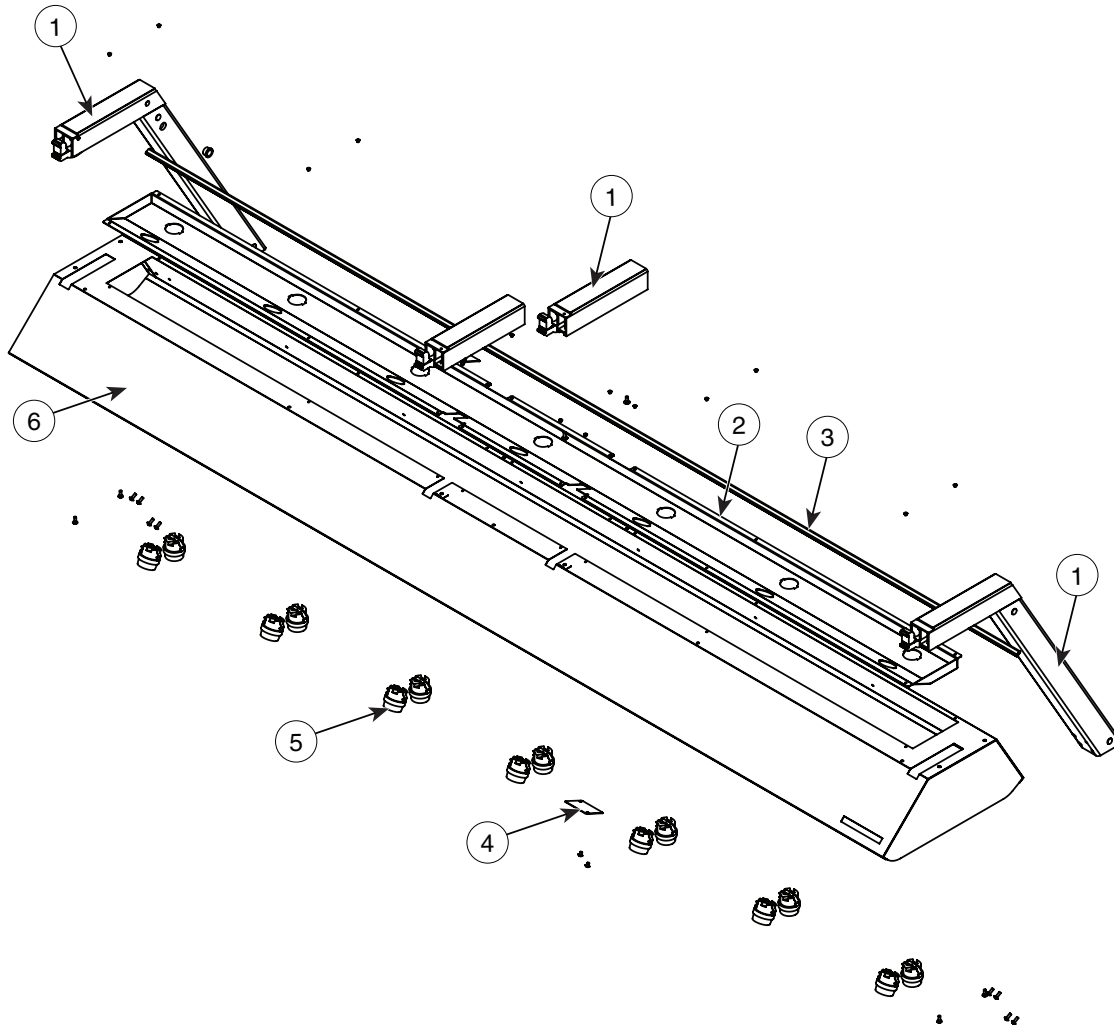

* NOT SHOWN		MODEL >	TY2(SYS)-48		TY2(SYS)-72		TY2(SYS)-96	
ITEM	DESCRIPTION	PART NO.	QTY	PART NO.	QTY	PART NO.	QTY	
1	HINGE KIT (SERVICE)	HG-28545	2	HG-28545	3	HG-28545	4	
2	LIGHT CHANNEL	1004357	1	1004358	1	1004359	1	
3	GASKET	FR-22496	4	FR-22496	6	FR-22496	8	
4	LIGHT CHANNEL COVER PLATE	—	—	1005372	1	1005372	2	
5	LAMP RECEPTACLE	120V/208-240V	RP-3952	6	RP-3952	10	RP-3952	14
	LAMP RECEPTACLE	230V	RP-3955	6	RP-3955	10	RP-3955	14
6	INNER TOP		5001733	1	5001934	1	5001937	1
7*	STRUT	500N	SU-24829	2	SU-24829	2	SU-24829	2
		800N	SU-24830	—	SU-24830	1	SU-24830	2

# SERVICE

## CABLE REPLACEMENT KITS

### 48 SERIES CABLE REPLACEMENT KIT

#### CABLE HEATING SERVICE KIT NO. 4880

INCLUDES:

CB-3045	CABLE HEATING ELEMENT.....	134 FEET
CR-3226	RING CONNECTOR .....	4
IN-3488	INSULATION CORNER.....	1 FOOT
BU-3105	SHOULDER BUSHING .....	4
BU-3106	CUP BUSHING .....	4
SL-3063	INSULATING SLEEVE .....	4
TA-3540	HIGH TEMPERATURE TAPE .....	1 ROLL
ST-2439	STUD, 10/32 .....	4
NU-2215	HEX NUT.....	8

### 72 SERIES CABLE REPLACEMENT KIT

#### CABLE HEATING SERVICE KIT NO. 4881

INCLUDES:

CB-3045	CABLE HEATING ELEMENT.....	210 FEET
CR-3226	RING CONNECTOR .....	12
IN-3488	INSULATION CORNER.....	1 FOOT
BU-3105	SHOULDER BUSHING .....	12
BU-3106	CUP BUSHING .....	12
SL-3063	INSULATING SLEEVE .....	12
TA-3540	HIGH TEMPERATURE TAPE .....	1 ROLL
ST-2439	STUD, 10/32 .....	12
NU-2215	HEX NUT.....	24

### 96 SERIES CABLE REPLACEMENT KIT

#### CABLE HEATING SERVICE KIT NO. 14228

INCLUDES:

CB-3045	CABLE HEATING ELEMENT.....	280 FEET
CR-3226	RING CONNECTOR .....	8
IN-3488	INSULATION CORNER.....	1 FOOT
BU-3105	SHOULDER BUSHING .....	8
BU-3106	CUP BUSHING .....	8
SL-3063	INSULATING SLEEVE .....	8
TA-3540	HIGH TEMPERATURE TAPE .....	1 ROLL
ST-2439	STUD, 10/32 .....	8
NU-2215	HEX NUT.....	16

## CAUTION



The performance of this unit has been optimized using the factory provided bulbs. These bulbs should be replaced with an exact replacement or with a factory recommended replacement. These bulbs have been treated to resist breakage and must be replaced with similarly treated bulbs in order to maintain compliance with NSF standards. **DO NOT** over-tighten bulbs in their receptacles as this can cause damage to the bulb filament.



## DANGER



**DISCONNECT UNIT FROM POWER SOURCE BEFORE CLEANING OR SERVICING.**

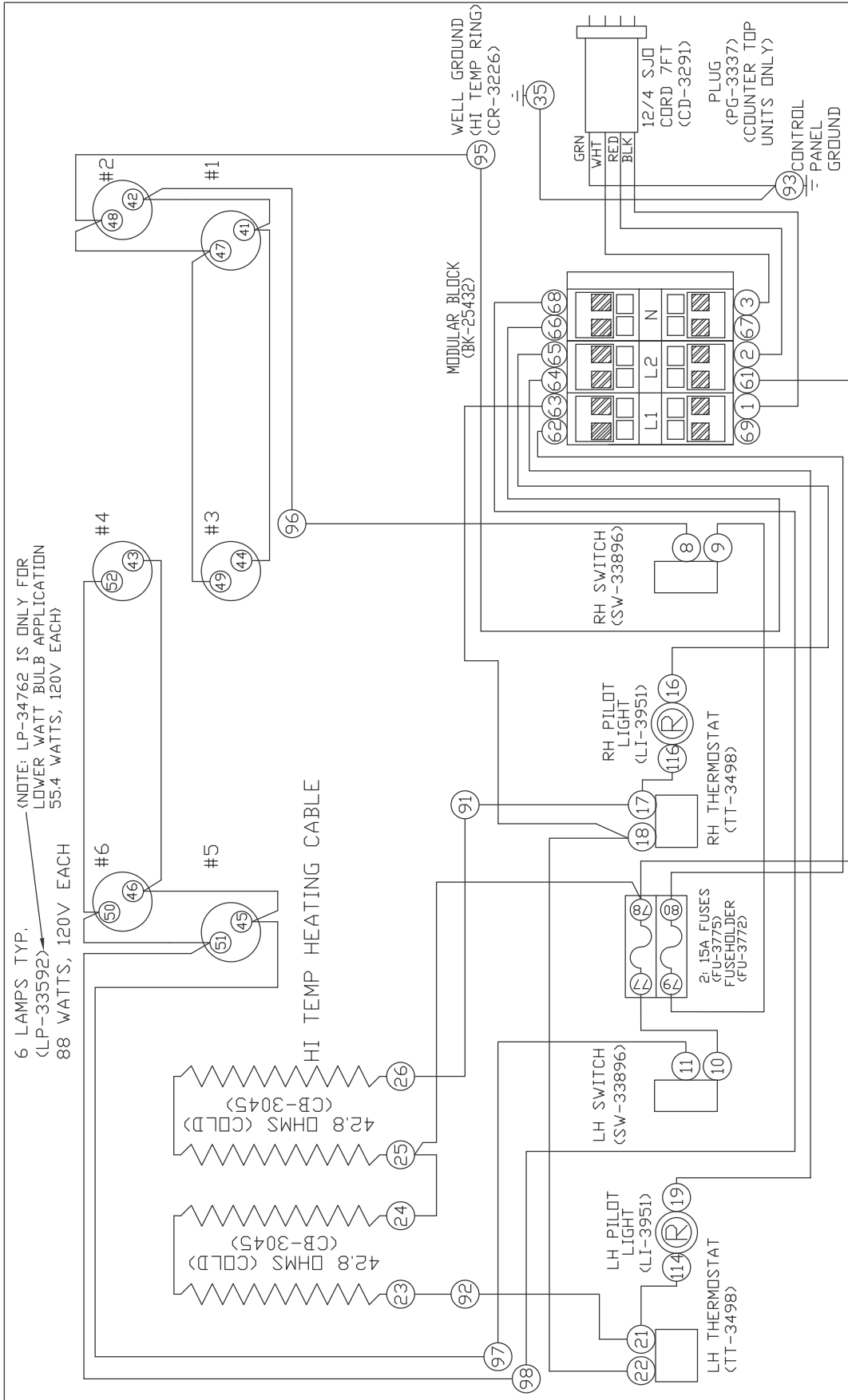

REV	ECO	DESCRIPTION	DATE	APP
5	5917	FLIP T-BLOCK WIRING	2/14/11	JPK
4	5396	RELEASED TO PRODUCTION	4/03/09	KDS
3.01	-	BULB CHANGE	3/16/09	JPK
EC2,ED2,HN2,PD2,TY2 (SYS)-48 & /P				

RATINGS WITH 55.4 WATT BULB		
VOLTS	WATTS	AMPS
208V	2295W	10.2A
240V	2946W	12.3A
120/208-240V	3320W	13.8A

RATINGS WITH 88 WATT BULB		
VOLTS	WATTS	AMPS
208V	2491W	11.6A
240V	3142W	13A
120/208-240V	3320W	13.8A

**ALTO-SHAAM**  
 WIRING DIAGRAM  
 DWG: 7661  
 SHEET 1\_OF\_1

NOTE #1: ALL NUMBERS IN ( ) = ALTO-SHAAM PART NO'S  
 NOTE #2: SEE DRW. B-8166 FOR WIRE ASSEMBLIES



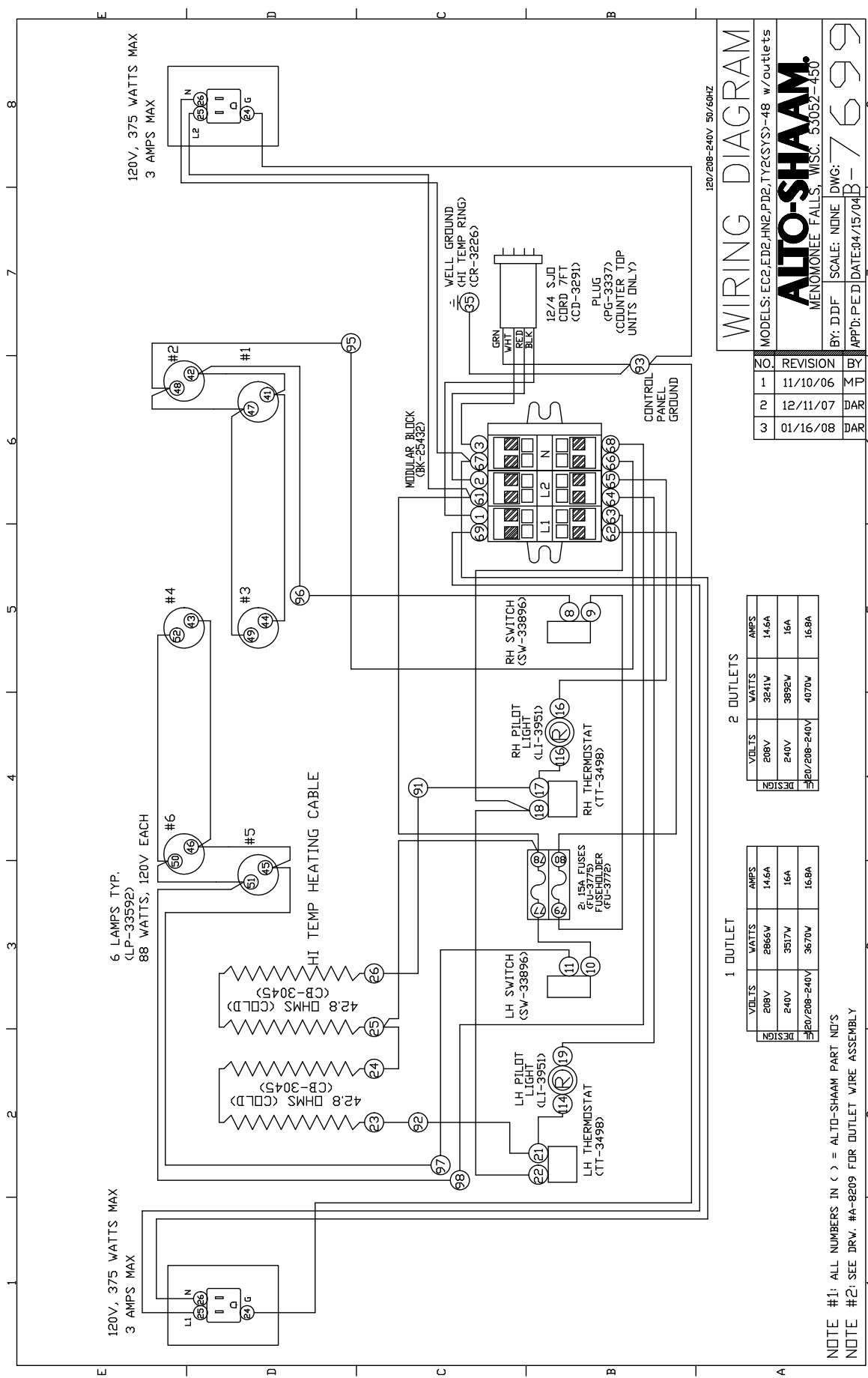

**WIRING DIAGRAM**

120/208-240V 50/60HZ

MODELS: EC2, ED2, HNG, PD2, TY2(SYS)-48 w/outlets

**ALTO-SHAAM**  
 MENOMONEE FALLS, WISC. 53052-450

BY: D.D.F. SCALE: NONE DWG: B-7699

APP'D: P.E.D DATE: 04/15/04

NO	REVISION	BY
1	11/10/06	M.D.
2	12/11/07	DAR
3	01/16/08	DAR

2 OUTLETS

VOLTS	WATTS	AMPS
208V	3841W	14.6A
240V	3892W	16A
208/208-240V	4070W	16.8A

1 OUTLET

VOLTS	WATTS	AMPS
208V	2865W	14.6A
240V	3517W	16A
208/208-240V	3670W	16.8A

NOTE #1: ALL NUMBERS IN ( ) = ALTO-SHAAM PART NO'S

NOTE #2: SEE DRW. #A-8209 FOR OUTLET WIRE ASSEMBLY

6 LAMPS TYP.  
(LP-33783)  
88 WATTS, 230V EACH

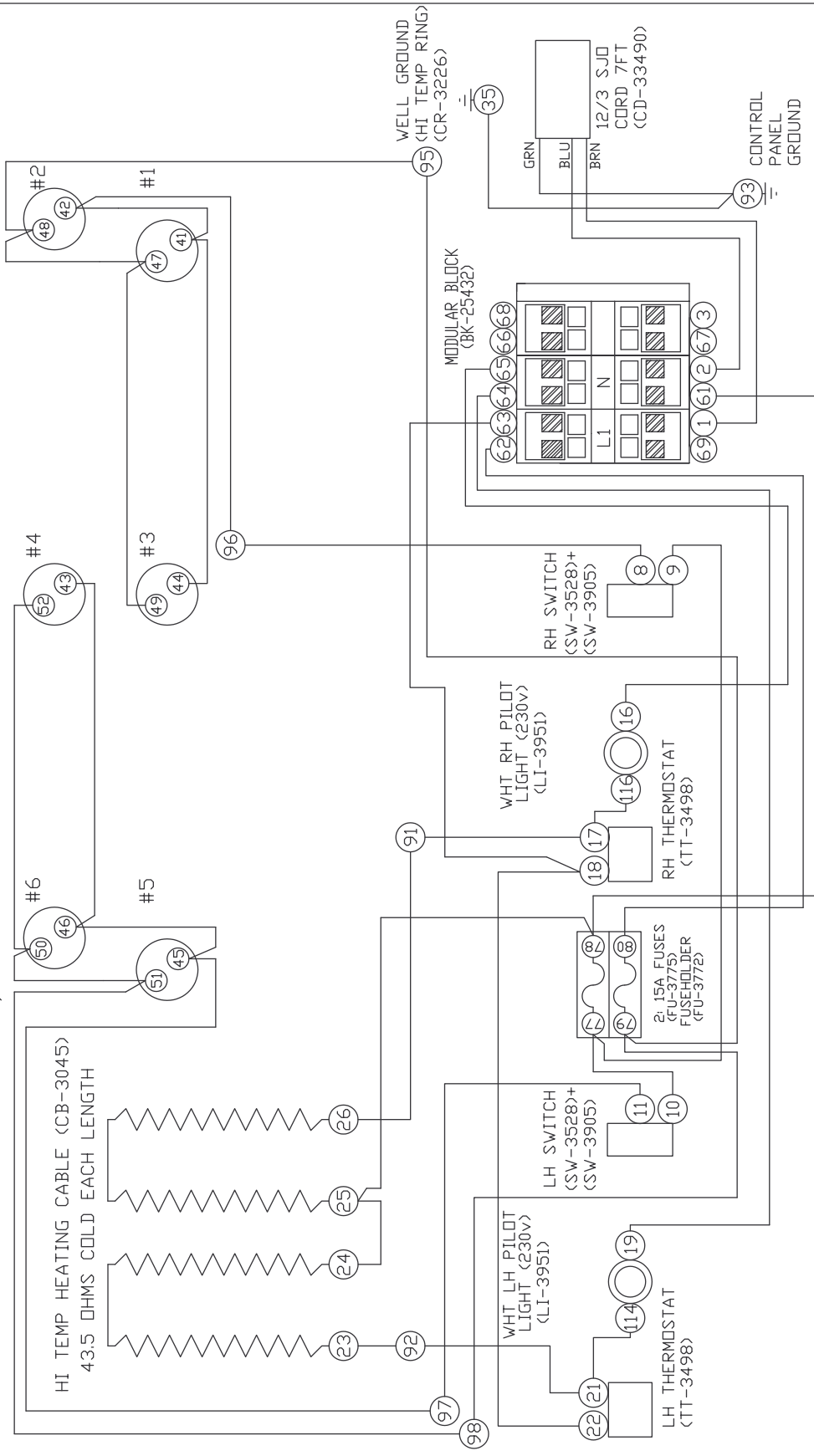

4	5917	FLIP T-BLOCK WIRING	2/14/11	JPK
3	5878	CHANGE SWITCH P/N FROM SW-34718 TO SW-3528+SW-3905	1/31/11	JPK
2	5443	RELEASED TO PRODUCTION	7/14/09	ARTR
REV	ECO	DESCRIPTION	DATE	APP
EC2,ED2,HN2,PD2,TY2(SYS)-48 /P 230V 50HZ				

DESIGN	VOLTS	WATTS	AMPS
B5	230V	2892W	12.6A
B6	230V	2900W	12.6A

NOTE: AG = AGENCY

NOTE #1: ALL NUMBERS IN ( ) = ALTO-SHAAM PART NO'S  
NOTE #2: SEE DRW. A-8190 FOR WIRE ASSEMBLIES

**ALTO-SHAAM**

BY: DDF DATE: 1/6/04  
DWG: 7679  
SHEET 1\_DF\_1

**WIRING DIAGRAM**

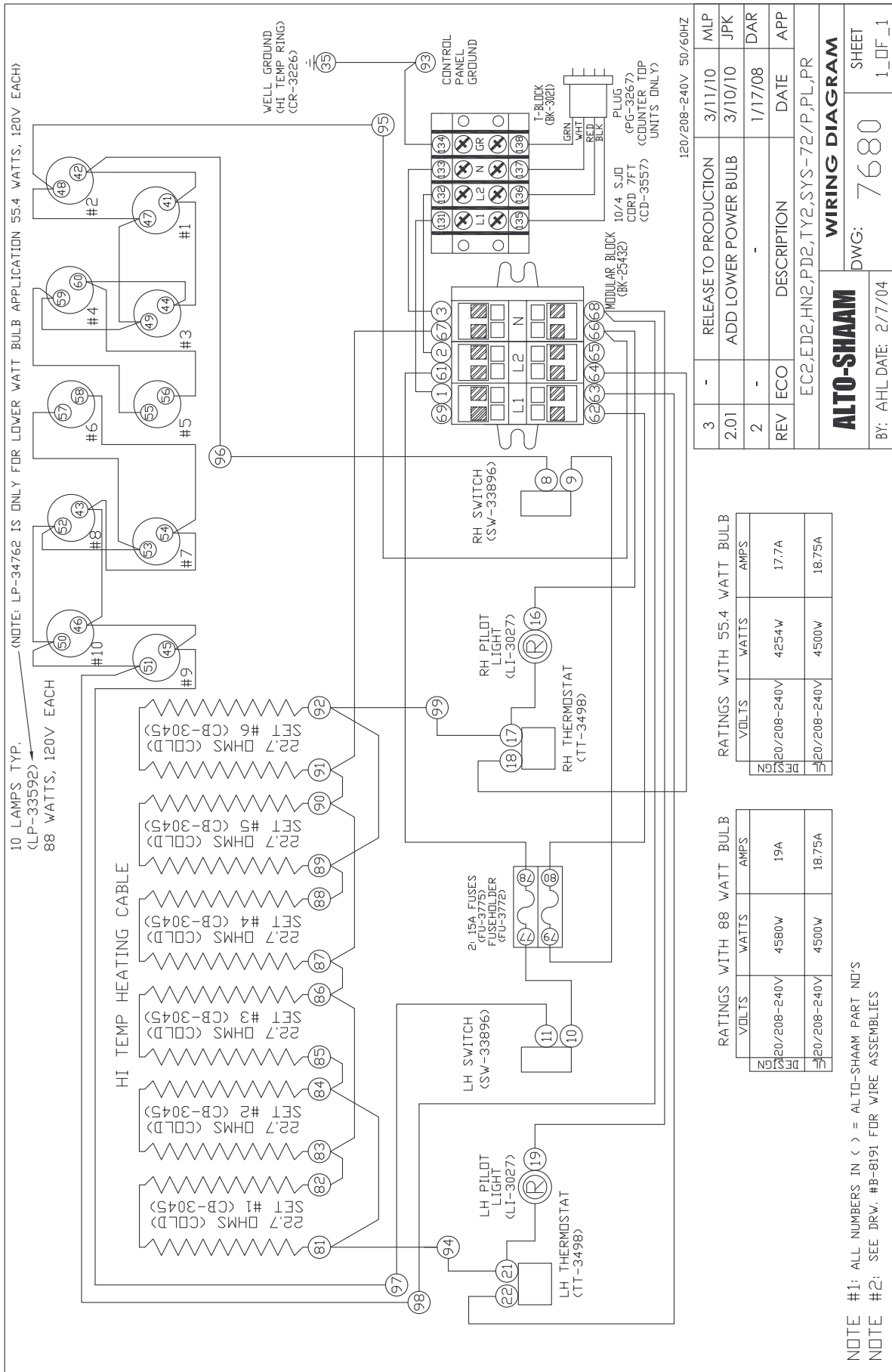

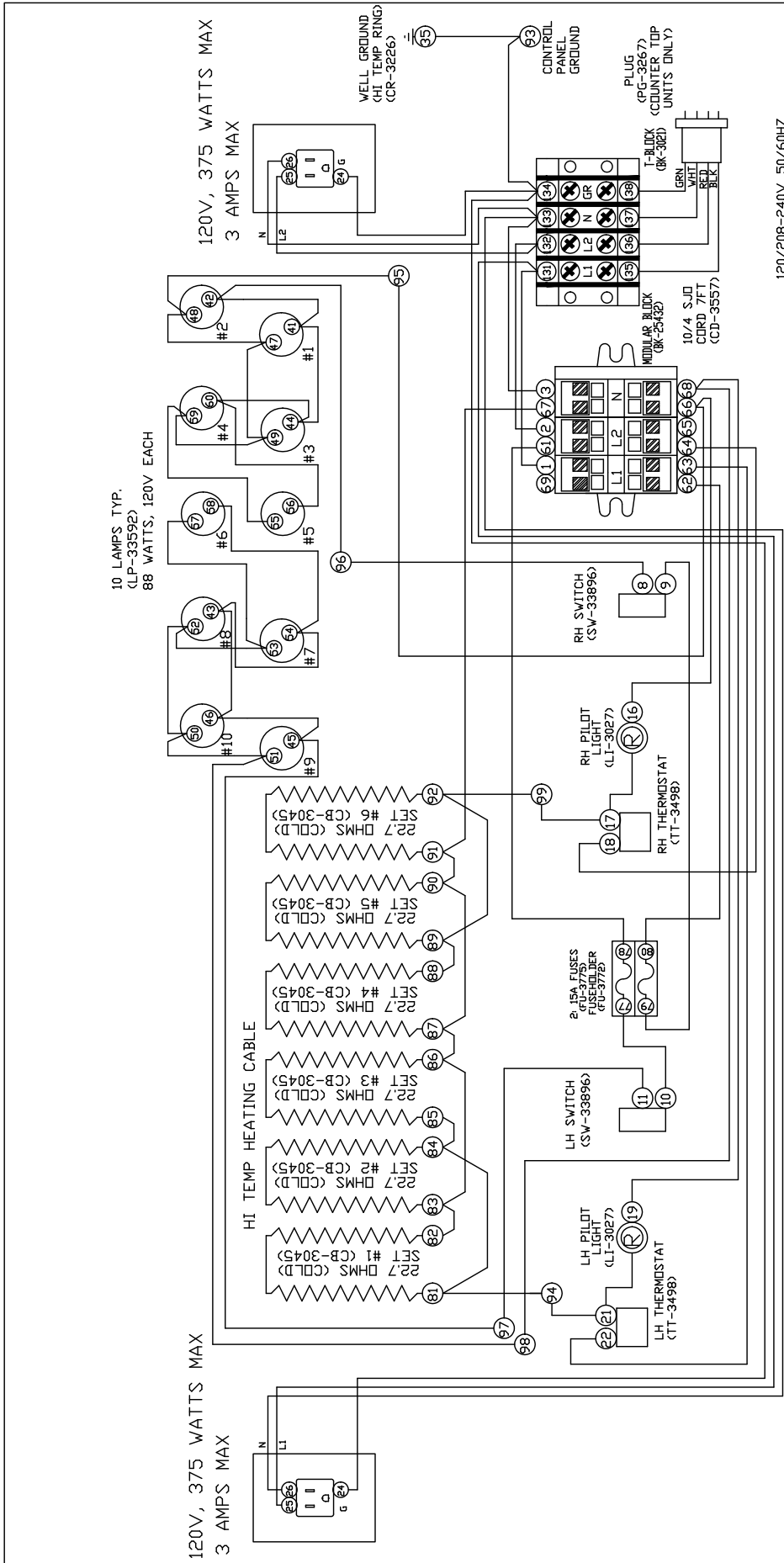

120/208-240V 50/60HZ

# WIRING DIAGRAM

MODELS: EC2,ED2,HN2,PD2,TY2(SYS)-72 w/outlets

**ALTO-SHAAM**  
MENOMONEE FALLS, WISC. 53052-450

NO.	REVISION	BY	DATE	SCALE	DWG:
1	01/17/08	BAR	04/15/04	NONE	7700

2 OUTLETS	
VOLTS	AMPS
20/208-240V	22A
20/208-240V	23A

1 OUTLET	
VOLTS	AMPS
20/208-240V	22A
20/208-240V	22A

NOTE #1: ALL NUMBERS IN ( ) = ALTO-SHAAM PART NO'S  
NOTE #2: SEE DRW. #A-8209 FOR OUTLET WIRE ASSEMBLY

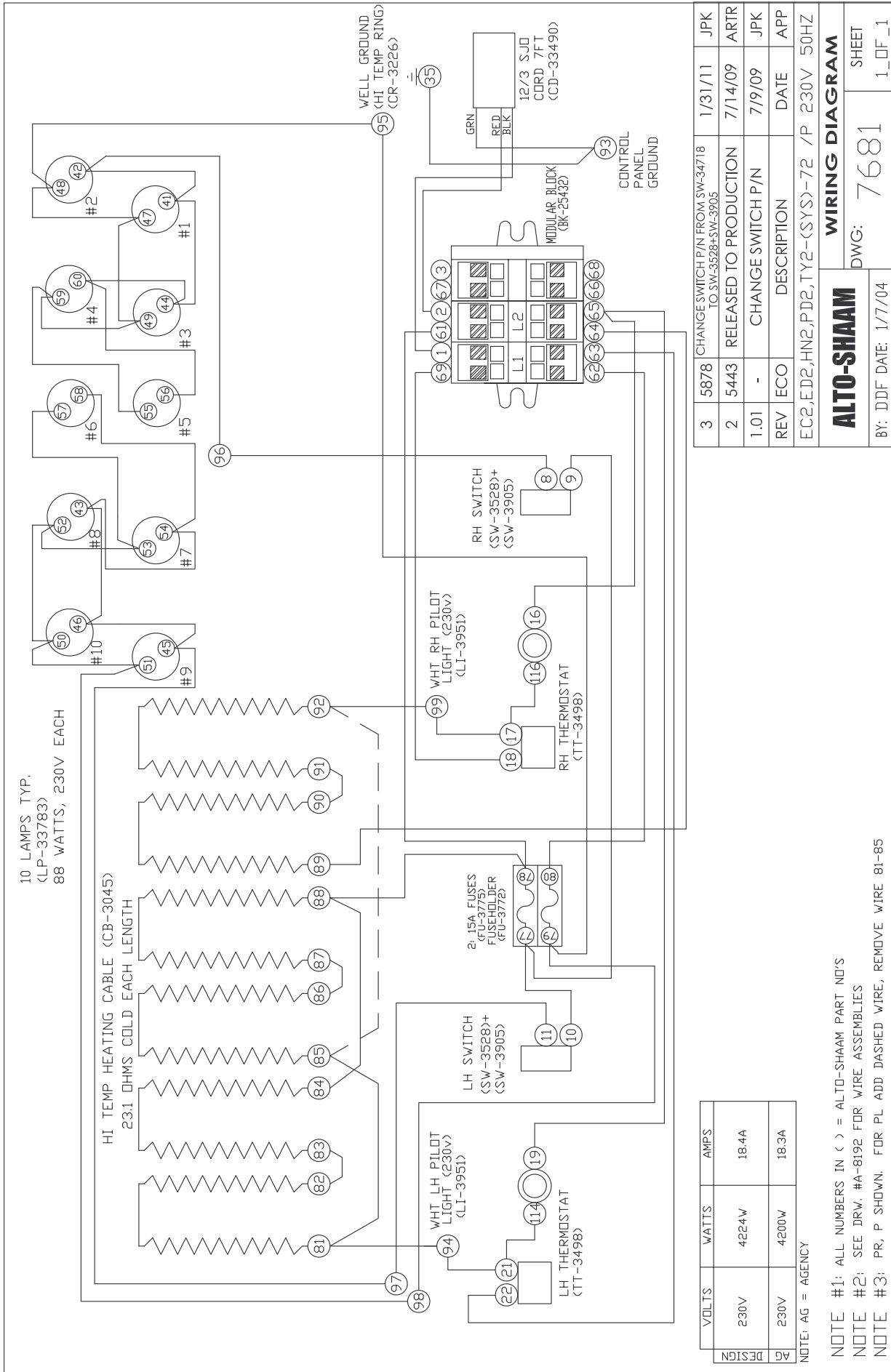

3	5878	CHANGE SWITCH P/N FROM SW-34718 TO SW-3528+SW-3905	1/31/11	JPK
2	5443	RELEASED TO PRODUCTION	7/14/09	ARTR
1.01	-	CHANGE SWITCH P/N	7/9/09	JPK
REV	ECO	DESCRIPTION	DATE	APP
EC2,ED2,HN2,PD2,TY2-(SYS)-72 / P 230V 50HZ				

<b>ALTO-SHAAM</b>		<b>WIRING DIAGRAM</b>	
BY: DDF DATE: 1/7/04		DWG: 7681	
		SHEET 1_OF_1	

VOLTS	WATTS	AMPS
230V	4224W	18.4A
230V	4200W	18.3A

NOTE #1: ALL NUMBERS IN ( ) = ALTO-SHAAM PART NOS  
 NOTE #2: SEE DRW. #A-8192 FOR WIRE ASSEMBLIES  
 NOTE #3: PR, P SHOWN. FOR PL ADD DASHED WIRE, REMOVE WIRE 81-85  
 NOTE: AG = AGENCY

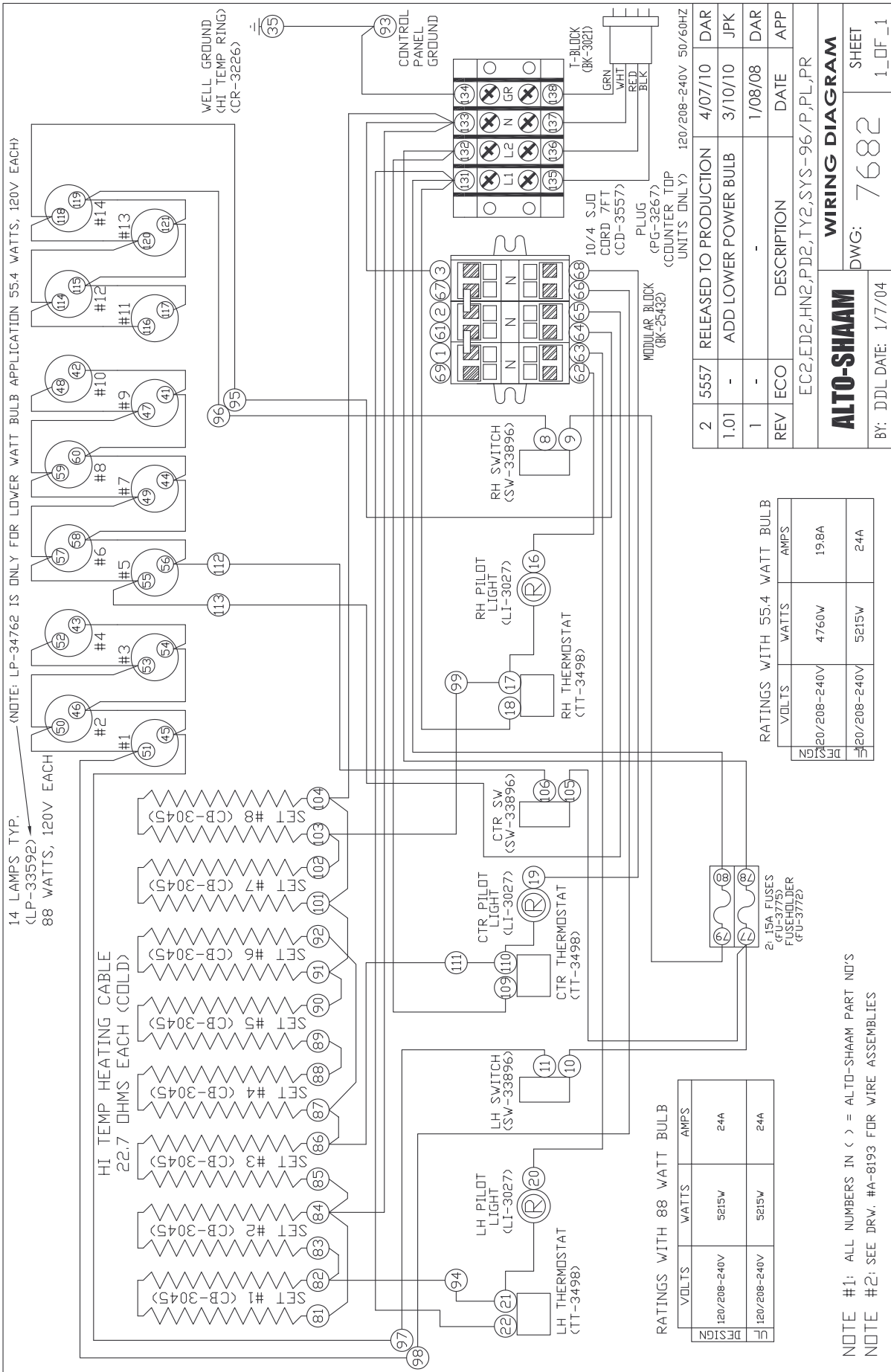

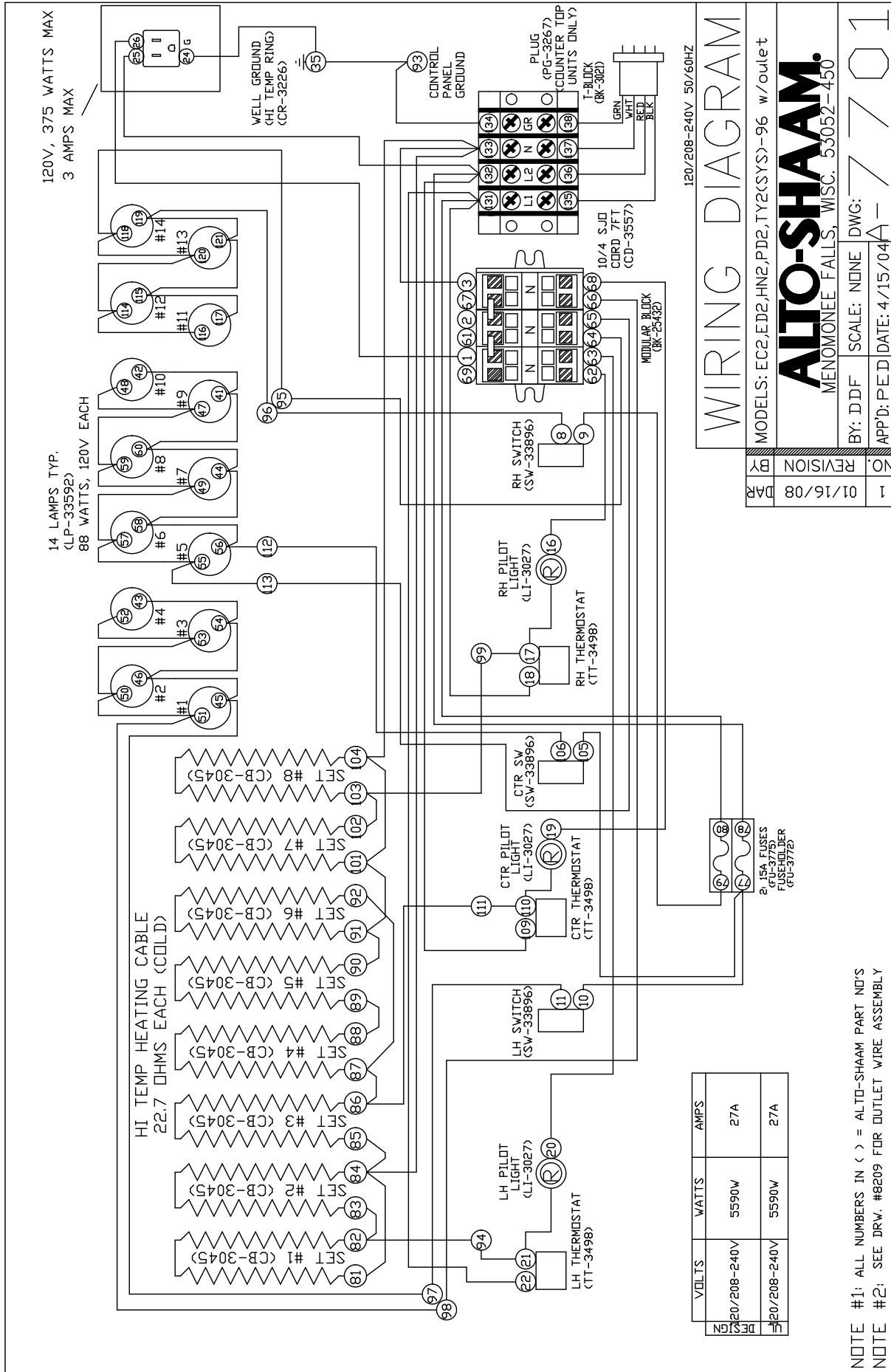

# WIRING DIAGRAM

120/208-240V 50/60HZ

MODELS: EC2,ED2,HN2,PD2,TY2(SYS)-96 w/outlet

**ALTO-SHAAM**  
MENOMONEE FALLS, WISC. 53052-450

BY	REVISION	BY
DA	01/16/08	DA

NO.	SCALE	DWG.
1	NONE	A-7701

BY: D.D.F. SCALE: NONE DWG: A-7701  
APP'D: P.E.D. DATE: 4/15/04

NOTE #1: ALL NUMBERS IN ( ) = ALTO-SHAAM PART NO'S  
NOTE #2: SEE DRW. #8209 FOR OUTLET WIRE ASSEMBLY

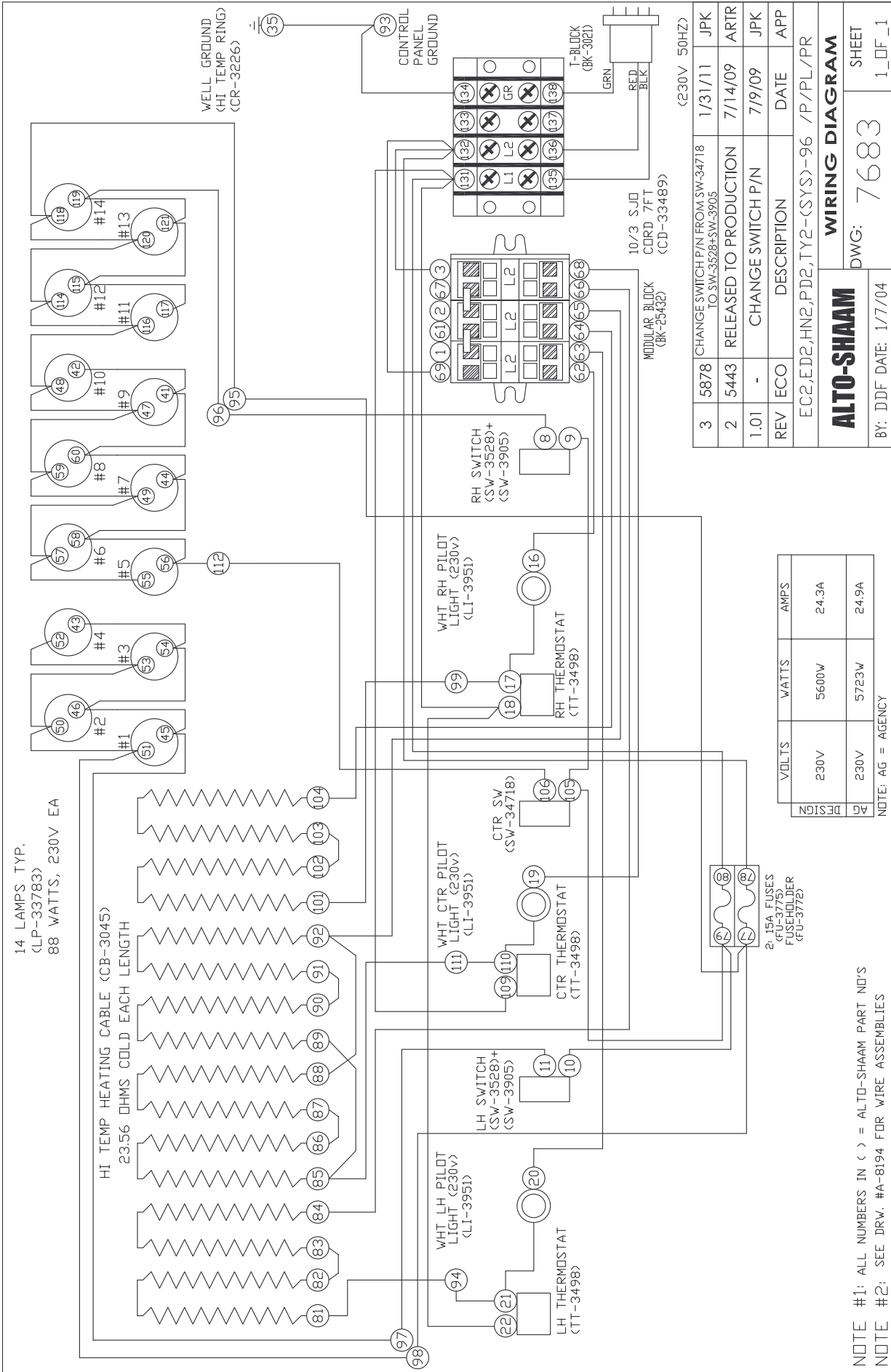

**ALTO-SHAAM**  
DWG: 7683  
BY: DDF DATE: 1/7/04

**WIRING DIAGRAM**  
SHEET 1\_OF\_1



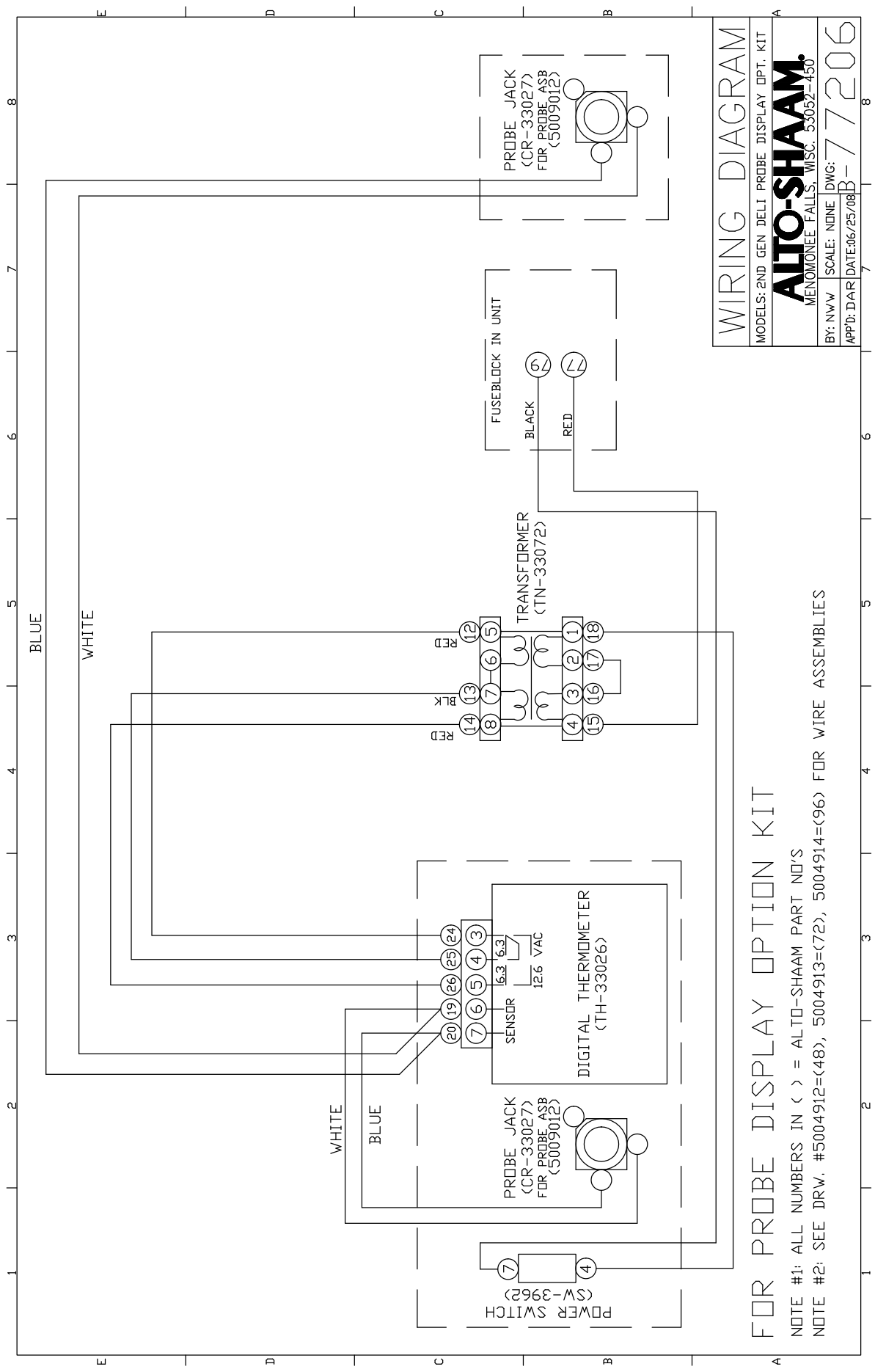

**WIRING DIAGRAM**

MODELS: 2ND GEN DELI PROBE DISPLAY OPT. KIT

**ALTO-SHAAM**  
 MENOMONEE FALLS, WISC. 53052-450

BY: NW/V SCALE: NONE DWG: 77206  
 APP'D: DAR DATE: 06/25/08 B

**FOR PROBE DISPLAY OPTION KIT**

NOTE #1: ALL NUMBERS IN ( ) = ALTO-SHAAM PART NO'S  
 NOTE #2: SEE DRW. #5004912-(48), 5004913-(72), 5004914-(96) FOR WIRE ASSEMBLIES

# TRANSPORTATION DAMAGE and CLAIMS



All Alto-Shaam equipment is sold F.O.B. shipping point, and when accepted by the carrier, such shipments become the property of the consignee.

Should damage occur in shipment, it is a matter between the carrier and the consignee. In such cases, the carrier is assumed to be responsible for the safe delivery of the merchandise, unless negligence can be established on the part of the shipper.

1. Make an immediate inspection while the equipment is still in the truck or immediately after it is moved to the receiving area. Do not wait until after the material is moved to a storage area.
2. Do not sign a delivery receipt or a freight bill until you have made a proper count and inspection of all merchandise received.
3. Note all damage to packages directly on the carrier's delivery receipt.
4. Make certain the driver signs this receipt. If he refuses to sign, make a notation of this refusal on the receipt.
5. If the driver refuses to allow inspection, write the following on the delivery receipt:  
*Driver refuses to allow inspection of containers for visible damage.*
6. Telephone the carrier's office immediately upon finding damage, and request an inspection. Mail a written confirmation of the time, date, and the person called.
7. Save any packages and packing material for further inspection by the carrier.
8. Promptly file a written claim with the carrier and attach copies of all supporting paperwork.

We will continue our policy of assisting our customers in collecting claims which have been properly filed and actively pursued. We cannot, however, file any damage claims for you, assume the responsibility of any claims, or accept deductions in payment for such claims.

## LIMITED WARRANTY

Alto-Shaam, Inc. warrants to the original purchaser only that any original part that is found to be defective in material or workmanship will, at Alto-Shaam's option, subject to provisions hereinafter stated, be replaced with a new or rebuilt part.

### The parts warranty period is as follows:

For the refrigeration compressor on Alto-Shaam Quickchillers™, five (5) years from the date of installation.

For the heating element on Halo Heat® cook/hold ovens, as long as the original purchaser owns the oven.

For all other parts, one (1) year from the date of installation or fifteen (15) months from the shipping date, whichever occurs first.

The labor warranty period is one (1) year from the date of installation or fifteen (15) months from the shipping date, whichever occurs first.

Alto-Shaam will bear normal labor charges performed during standard business hours, excluding overtime, holiday rates or any additional fees.

To be valid, a warranty claim must be asserted during the applicable warranty period. This warranty is not transferable.

### THIS WARRANTY DOES NOT APPLY TO:

1. Calibration.
2. Replacement of light bulbs, door gaskets, and/or the replacement of glass due to damage of any kind.
3. Equipment damage caused by accident, shipping, improper installation or alteration.
4. Equipment used under conditions of abuse, misuse, carelessness or abnormal conditions, including but not limited to, equipment subjected to harsh or inappropriate chemicals, including but not limited to, compounds containing chloride or quaternary salts, poor water quality, or equipment with missing or altered serial numbers.
5. Damage incurred as a direct result of poor water quality, inadequate maintenance of steam generators and/or surfaces affected by water quality. Water quality and required maintenance of steam generating equipment is the responsibility of the owner/operator.
6. Damage caused by use of any cleaning agent other than Alto-Shaam's Combitherm® Cleaner, including but not limited to damage due to chlorine or other harmful chemicals. **Use of Alto-Shaam's Combitherm® Cleaner on Combitherm® ovens is highly recommended.**
7. Any losses or damage resulting from malfunction, including loss of product or consequential or incidental damages of any kind.
8. Equipment modified in any manner from original model, substitution of parts other than factory authorized parts, removal of any parts including legs, or addition of any parts.

This warranty is exclusive and is in lieu of all other warranties, express or implied, including the implied warranties of merchantability and fitness for a particular purpose. In no event shall Alto-Shaam be liable for loss of use, loss of revenue or profit, or loss of product, or for any indirect, special, incidental, or consequential damages. No person except an officer of Alto-Shaam, Inc. is authorized to modify this warranty or to incur on behalf of Alto-Shaam any other obligation or liability in connection with Alto-Shaam equipment.

Effective 09/10



RECORD THE MODEL AND SERIAL NUMBER OF THE APPLIANCE FOR EASY REFERENCE.

ALWAYS REFER TO BOTH MODEL AND SERIAL NUMBER IN ANY CONTACT WITH ALTO-SHAAM REGARDING THIS APPLIANCE.

Model: \_\_\_\_\_ Date Installed: \_\_\_\_\_  
Voltage: \_\_\_\_\_ Purchased From: \_\_\_\_\_  
Serial Number: \_\_\_\_\_

W164 N9221 Water Street • P.O. Box 450 • Menomonee Falls, Wisconsin 53052-0450 • U.S.A.

PHONE: 262.251.3800 • 800.558-8744 USA/CANADA FAX: 262.251.7067 • 800.329.8744 U.S.A. ONLY

www.alto-shaam.com

PRINTED IN U.S.A.