

ASSEMBLY INSTRUCTIONS
 for KNOCK DOWN RACKS
 275-70-1824-KD, 275-70-1820-KD and 275-38-1810-KDT

TOOLS NEEDED:

7/16" & 9/16" Socket Head Wrench

**RACK PARTS SUPPLIED for
 275-70-1824-KD, 275-70-1820-KD**

| <u>QTY</u> | <u>DESCRIPTION</u> |
|------------|-------------------------------------|
| 2 | Side assemblies, welded with angles |
| 6 | Support braces, with tapped holes |
| 4 | Casters, 5" dia. swivel |
| 8 | Clips, washer |
| 12 | Screws, hex head machine 5/16-18 |

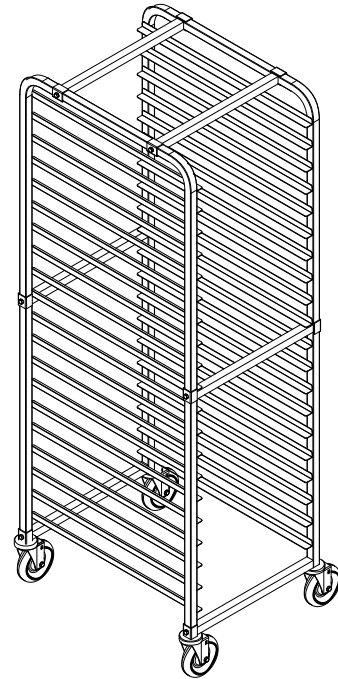

Figure 1
275-70-1820-KD

**RACK PARTS SUPPLIED for
 275-38-1810-KDT**

| <u>QTY</u> | <u>DESCRIPTION</u> |
|------------|-------------------------------------|
| 2 | Side assemblies, welded with angles |
| 4 | Support braces, with tapped holes |
| 4 | Casters, 5" dia. swivel |
| 4 | Clips, washer |
| 8 | Screws, hex head machine 5/16-18 |
| 1 | Top shelf |

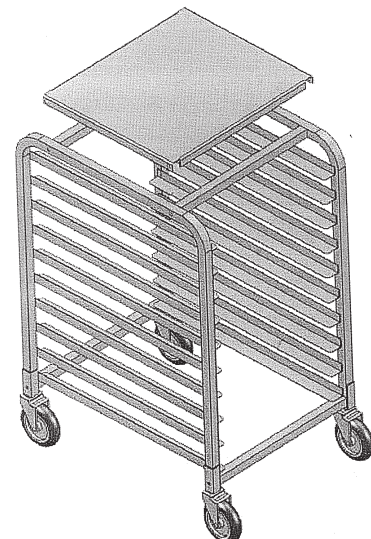

Figure 2
275-38-1810-KDT

REPLACEMENT PARTS:

| <u>DESCRIPTION</u> | <u>PART NO.</u> |
|-------------------------|-----------------|
| Loose Hardware Kit..... | 6274-021 |
| Top Shelf Kit..... | 1269-052 |
| Brace Support Kit | 0520-051 |
| Caster Kit (Plate)..... | 0569-327-K |
| Caster Kit (Stem) | 0569-328-K |

| | |
|------------------|-------------|
| KD Rack Assembly | FL-2350 |
| Rev. 3 (5/12) | Page 2 of 2 |

ASSEMBLY INSTRUCTIONS for KNOCK DOWN RACKS

275-70-1824-KD, 275-70-1820-KD and 275-38-1810-KDT

HOW TO ASSEMBLE FULL-SIZE RACKS 275-70 SERIES:

1. Attach (4) support braces to the angle side of one of the side assemblies; (2) at the top and (2) at the center holes on the side tubing with the clips and screws provided (See Fig. 3).
 - a. Slide the clip around the outside of the tubing lining up the hole with the hole in the tubing post.
 - b. Insert the screw through the clip into the support brace.
2. Place the second side assembly (with angles facing each other) against the support braces; lining up the holes.
3. Add (4) more clips and fasten together with the screws.
4. Turn the rack so the front opening of the rack is facing you.
5. Insert the (2) casters with brakes into each bottom of the side tubing on that same opening of the rack.
(For model 275-70-1824-KD only).
6. Insert a support brace in between the side tubings and fasten them to the brace with screws.
7. Lift and turn the rack to insert the other (2) casters on the other side and fasten them to the side tubing and support braces with the screws.
8. Stand the rack upright and make sure all screws are tight.

HOW TO ASSEMBLE HALF-SIZE RACK 275-38 SERIES:

1. Place one side assembly on the floor with angles facing up and insert (2) casters into the bottom of the side tubing.
2. Repeat with the second side assembly.
3. Attach the (2) support braces to the angle side of one of the assemblies by lining them up with the caster hole on the side tubing with the hole in the support brace. Fasten together with screws.
4. Place the second side assembly (with angles facing each other) against the support braces; lining up the holes at the bottom. Fasten with screws.
5. Insert the (2) support braces under the top shelf between the side assemblies; lining up the holes. Add (4) clips and fasten with screws.
6. Place the top shelf over the side and top tubing and push shelf down to fit.
7. Make sure all screws are tight.

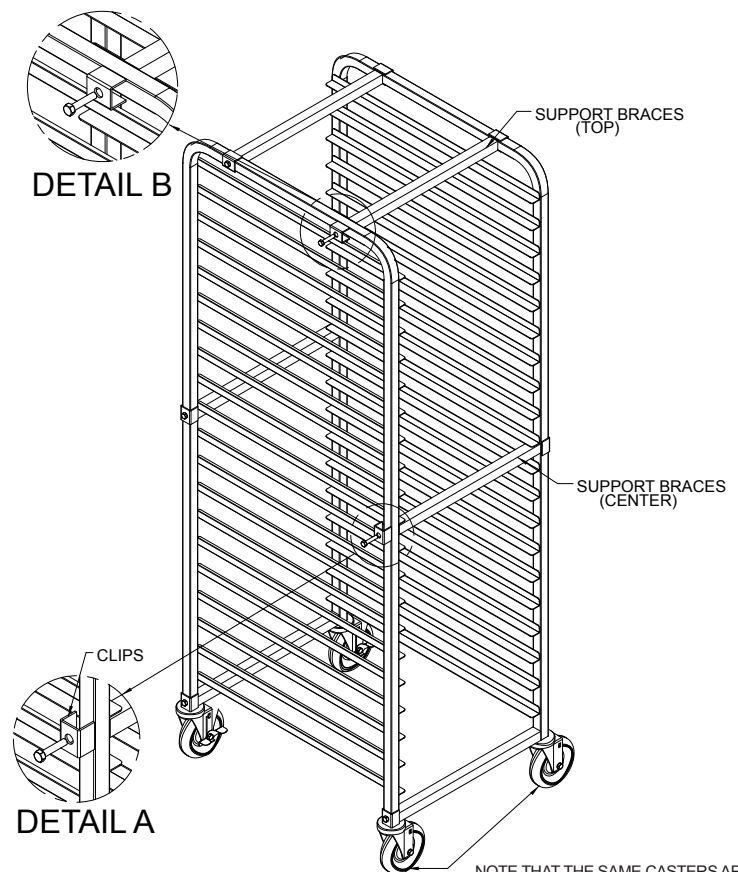

Figure 3
275-70-1820-KD

NOTE THAT THE SAME CASTERS ARE MOUNTED ON THE SAME SIDE OF THE RACK OPENING. CASTERS WITH BRAKES ARE ON MODEL 275-70-1824KD ONLY