

CORRECTIONAL NON-INSULATED UTILITY CABINET MODEL 150-1838-DZ

FEATURES AND BENEFITS:

- Non-insulated heavy duty cabinet for transport and storage for a rugged environment.
- Same size top and base extend past sidewalls to act as natural bumpers for protection. Extruded frame fully welded.
- Body constructed of reinforced, Hi-Tensile aluminum for strength and durability.
- Interlocking extruded sidewalls hold 18" x 26" pans and plastic food boxes on 1-1/2" centers. Reinforced with additional vertical extruded channels which are riveted and welded in place.
- One-piece, reinforced, full length door swings 270°. Heavy duty security hinges attached with tamper-proof fasteners.
- Extended slide latch with two lock hasps covers 80% of door length for maximum security.
- Heavy duty extruded aluminum tie bars welded in place.
- Heavy duty 5" swivel casters, two with brakes. Provides mobility when fully loaded.



150-1838-DZ

SANITATION
NSF/ANSI 4

ACCESSORIES and OPTIONS

(Available at extra cost):

- Corner Bumpers
- Perimeter Bumper
- Push Handle
- Left-Hand Hinged Door
- Kold Keepers
- Various Caster Options

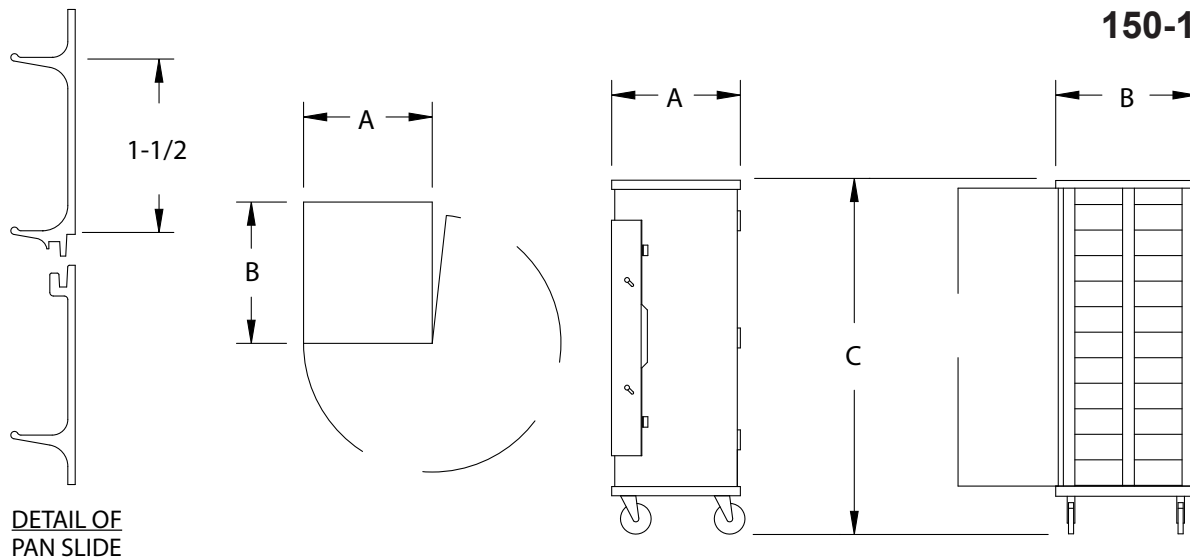

DETAIL OF PAN SLIDE

CRES COR MODEL NO.	PAN			DIM "A"	DIM "B"	DIM "C"	INSIDE DIMENSIONS			WEIGHT ACT.	
	CAP	SIZE		WIDTH	DEPTH	HEIGHT	WIDTH	DEPTH	HEIGHT		
150-1838-DZ	38	18 x 26	IN	20-7/8	27-1/2	69-3/4	18-1/16	26	61-1/2	LBS	125
		460 x 660	MM	530	700	1775	460	660	1565	KG	57

When ordering bumpers, add 2" to overall dimensions.

ALL ALUMINUM CONSTRUCTION IS RIVETED, WELDED AND FINISHED.

CABINET:

- Posts: Extruded channels, 7/8 x 2-1/4 x .102, welded to top and base, form a solid frame.
- Sides: Interlocking extruded 6" panels, smooth outer sides reinforced with 1 x 2 x .125 extruded channel, riveted and welded in place.
- Super Duty back panel: Fitted into posts, riveted to top and reinforced with additional bracing.
- Tie bar: Welded in place.
- Top: One piece .100 aluminum.

BASE:

- One piece construction, .190 aluminum.
- Casters: 5" dia., swivel, modulus tires, 1-1/4 wide, load cap. 250 lbs. each, temp. range -45°/+180°F. Delrin bearings. Front casters equipped with brakes.

DOOR:

- Panel: .100 formed aluminum.
- Reinforcement: 3/8 x 1-1/2 extruded bars riveted horizontally to top, center and bottom.
- Latch: Gravity type, .125 aluminum with lock hasps (top and bottom).
- Swings 270° on 5 butt hinges, riveted to post and door panel.

PAN SLIDES:

- Extruded interlocking side walls act as pan slides on 1-1/2" centers.

SHORT FORM SPECIFICATIONS

Cres Cor Correctional Utility Cabinet Model 150-1838-DZ. Formed and welded .100 aluminum top, .190 aluminum base. Interlocking extruded aluminum sidewalls for (38) 18" x 26" pans and plastic food boxes on 1-1/2" centers. Formed .100 aluminum reinforced door. Extended slide latch with two lock hasps covers 80% of door length. 5" swivel modulus casters, Delrin bearings. Load capacity 250 lbs. each. Provide the following accessories: _____ NSF listed. 1 year parts warranty.



Scan QR code to view Spec Sheet, Operating Manual, Wiring Diagram or to call Customer Service.

If you need a QR reader visit your App Store on your Smartphone or Tablet.



5925 Heisley Road • Mentor, OH 44060-1833
 Phone: 877/CRESCOR • Fax: 440/350-7267
 www.crescor.com

© Crescent Metal Products, Inc. 2017 All rights reserved.

In line with its policy to continually improve its products, CRES COR reserves the right to change materials and specifications without notice.

Made in America Since 1936